

---

FM 6-60  
MCRP 3-1.6.24

Tactics, Techniques, and Procedures for  
**MULTIPLE LAUNCH  
ROCKET SYSTEM  
(MLRS)  
OPERATIONS**

HEADQUARTERS  
DEPARTMENT OF THE ARMY  
UNITED STATES MARINE CORPS

**DISTRIBUTION RESTRICTION:** Approved for public release, distribution is unlimited.

---

FIELD MANUAL  
NO. 6-60  
MARINE CORPS REFERENCE PUBLICATION  
NO. 3-1.6.24

HEADQUARTERS  
DEPARTMENT OF THE ARMY  
U.S. MARINE CORPS  
Washington, DC, 23 April 1996

Tactics, Techniques and Procedures for  
**MULTIPLE LAUNCH ROCKET SYSTEM**  
**(MLRS)**  
**OPERATIONS**

**Table of Contents**

---

	Page
<b>PREFACE</b> .....	vii
<b>CHAPTER 1. SYSTEM DESCRIPTION</b>	
<i>Section I. INTRODUCTION</i> .....	1-1
MLRS Employment Concept .....	1-1
System Components .....	1-1
<i>Section II. LAUNCHERS AND SUBSYSTEMS</i> .....	1-2
M270 Launcher .....	1-2
M993 Carrier Vehicle .....	1-2
M269 LLM .....	1-2
FCS Functions .....	1-4
<i>Section III. MLRS FAMILY OF MUNITIONS (MFOM)</i> .....	1-5
Launch POD .....	1-5
Rockets .....	1-5
Missiles .....	1-7
Future Developmental Munitions .....	1-8
<i>Section IV. ASSOCIATED EQUIPMENT</i> .....	1-9
Ammunition Resupply Vehicle and Trailer (HEMTT/HEMAT) .....	1-9
Command, Control and Communications System .....	1-10
Fire Direction System .....	1-10
Fire Direction Data Manager .....	1-11

**DISTRIBUTION RESTRICTION:** Approved for public release, distribution is unlimited.

\* This publication supersedes FM 6-60, 16 September 1992-

PCN: 144 000003 00

	page
Forward Entry Device .....	1-11
Survey Equipment .....	1-11
<b>CHAPTER 2. ORGANIZATION</b>	
<i>Section I. STRUCTURE</i> .....	2-1
MLRS Battalion .....	2-1
Headquarters, Headquarters and Service Battery .....	2-1
MLRS Firing Batteries .....	2-4
<i>Section II. DUTIES OF KEY PERSONNEL</i> .....	2-6
MLRS Battalion .....	2-6
MLRS Firing Battery .....	2-8
<b>CHAPTER 3. EMPLOYMENT</b>	
<i>Section I. OPERATIONS IN WAR</i> .....	3-1
General Employment Considerations .....	3-1
Organization for Combat .....	3-4
Operations with the Marine Corps .....	3-7
Offensive Operations .....	3-9
Defensive Operations .....	3-9
Nonstandard Employment Techniques .....	3-10
Rehearsals .....	3-11
Target Acquisition and Sensor System Interface .....	3-13
<i>Section II. OPERATIONS OTHER THAN WAR</i> .....	3-15
The Principles .....	3-15
The Activities .....	3-16
Roles of the MLRS Unit .....	3-17
<b>CHAPTER 4. MLRS UNIT OPERATIONS</b>	
<i>Section I. BATTALION OPERATIONS</i> .....	4-1
Six Basic Tasks .....	4-1
Battalion Headquarters .....	4-1
Battalion Tactical Operations Center .....	4-2
Battalion Administrative and Logistics Operations Center .....	4-3
Functional Command Post .....	4-4
<i>Section II. MLRS FIRING BATTERY OPERATIONS</i> .....	4-4
Battery Headquarters .....	4-4
Split Headquarters Operations .....	4-5
Battery Headquarters Positioning Considerations .....	4-5
Battery Defense .....	4-6
Movement .....	4-7
Jump Battery Operations Center .....	4-8
Tactical Marches .....	4-8
Conduct of the Movement .....	4-9
March Discipline .....	4-11
March Column Contingencies .....	4-11

	page
Survey Support .....	4-12
Meteorological Support .....	4-14
<b>Section III. FIRING PLATOON OPERATIONS</b> .....	<b>4-16</b>
Platoon Headquarters .....	4-16
Operational Area (OPAREA) .....	4-16
Launcher Survey Control .....	4-18
Launcher Response Posture .....	4-19
Detachment of the MLRS Firing Platoon .....	4-21
<b>Section IV. RECONNAISSANCE, SELECTION, AND OCCUPATION OF POSITION</b> .....	<b>4-21</b>
Planning .....	4-21
Method .....	4-21
Preparation .....	4-21
Reconnaissance .....	4-22
Selection and Occupation of Position .....	4-22
Masking Data .....	4-24
<b>Section V. CONTINGENCY OPERATIONS</b> .....	<b>4-25</b>
Force Projection .....	4-25
Deployment .....	4-26
Deployment Packages .....	4-26
Special Operations .....	4-28
<b>CHAPTER 5. DELIVERY OF FIRES</b>	
<b>Section I. INTRODUCTION</b> .....	<b>5-1</b>
Organization and Structure .....	5-1
<b>Section II. MLRS FIRE DIRECTION CENTERS</b> .....	<b>5-3</b>
Battalion Level .....	5-3
Battery Level .....	5-3
Platoon Level .....	5-4
<b>Section III. MISSION PROCESSING</b> .....	<b>5-4</b>
General .....	5-4
Launcher Status Management .....	5-5
Fire Mission Execution Function .....	5-5
Fire Mission Support Function .....	5-7
Fire Support Scheduling Function .....	5-8
Fire Mission Cycle .....	5-9
Commander's Criteria .....	5-10
Target Criteria .....	5-12
MLRS Fire Plan Processing .....	5-12
<b>CHAPTER 6. COMBAT SERVICE SUPPORT</b>	
<b>Section I. ORGANIZATION</b> .....	<b>6-1</b>
Logistics .....	6-1
Logistics Support Areas .....	6-1
Logistics Operations .....	6-2



	page
<i>Section II. MANNING</i> .....	6-4
Personnel Readiness Management .....	6-4
Replacement Management .....	6-4
Casualty Management .....	6-4
<i>Section III. ARMING</i> .....	6-5
General .....	6-5
Resupply Operations .....	6-8
<i>Section IV. FIXING</i> .....	6-9
General .....	6-9
Levels of Maintenance .....	6-10
Battalion Maintenance Support .....	6-10
Firing Battery Maintenance Operations .....	6-11
<i>Section V. FUELING</i> .....	6-15
General .....	6-15
Fuel .....	6-15
Packaged Class III .....	6-15
<i>Section VI. MOVING</i> .....	6-17
<i>Section VII. SUSTAINING SOLDIERS AND THEIR SYSTEMS</i> .....	6-18
Personnel Service Support .....	6-18
Health Service Support .....	6-18
Field Service Support .....	6-19
Quality of Life .....	6-21
General Supply Support .....	6-22
<i>Section VIII. OTHER CSS RELATED FUNCTIONS</i> .....	6-23
Enemy Prisoners of War .....	6-23
Decontamination Operations .....	6-23
Reconstitution .....	6-23
Weapon System Replacement Operations .....	6-24
<i>Section XI. LOGISTICS OPERATIONS WITH THE MARINE CORPS</i> .....	6-25
Army .....	6-25
Marine Corps .....	6-25
<b>CHAPTER 7. COMMUNICATIONS</b>	
Requirements .....	7-1
Means .....	7-1
Responsibilities .....	7-2
Staff Responsibilities .....	7-2
Planning Considerations .....	7-3
Net Structures .....	7-5
Mobile Subscriber Equipment .....	7-11
Single Channel Ground and Airborne Radio System .....	7-12
Antennas .....	7-13

	page
<b>APPENDIX A. AERIAL TRANSPORT OF MLRS AMMUNITION AND EQUIPMENT</b>	
Aerial Ammunition Resupply .....	A-1
Transportation of MLRS Equipment on United States Air Force Aircraft .....	A-1
<b>APPENDIX B. FA SUPPORT PLAN .....</b>	<b>B-1</b>
<b>APPENDIX C. ROCKET BALLISTICS .....</b>	<b>C-1</b>
Requirements for Accurate Predicted Fire .....	C-1
Rocket Error Sources .....	C-1
<b>APPENDIX D. MLRS BATTALION AND BATTERY TACTICAL STANDARD OPERATING PROCEDURES</b>	
General .....	D-1
TSOP Format .....	D-1
<i>Section I. IMPLEMENTING MEMORANDUM (Battalion and Battery)</i> .....	D-2
<i>Section II. BATTALION TSOP</i> .....	D-3
<i>Section III. MLRS BATTERY TSOP</i> .....	D-14
<b>APPENDIX E. LNO CHECKLIST .....</b>	<b>E-1</b>
<b>APPENDIX F. MLRS FUNCTIONAL COMMAND POSTS</b>	
<i>Section I. MLRS BATTALION COMMAND POST</i> .....	F-1
<i>Section II. MLRS BATTALION TRAINS</i> .....	F-4
<i>Section III. MLRS BATTERY COMMAND POST</i> .....	F-9
<i>Section IV. MLRS BATTERY TRAINS</i> .....	F-11
<i>Section V. PLATOON HEADQUARTERS</i> .....	F-14
<b>APPENDIX G. HASTY SURVEY TECHNIQUES-GRAPHIC RESECTION</b>	
Description .....	G-1
Procedures .....	G-1
<b>APPENDIX H. ROCKET CREST CLEARANCE TABLES</b>	
Assumptions .....	H-1
Procedures .....	H-1
<b>APPENDIX I. LAUNCHER SECTION EVALUATION AND TRAINING</b>	
Scope .....	I-1
Purpose .....	I-1
Conduct of the Evaluation .....	I-1
<i>Phase I. ORIENTATION AND ORGANIZATION</i> .....	I-5
Task 1 - Written Test .....	I-5
<i>Phase II. PREPARATION FOR OPERATIONS</i> .....	I-9
Task 2 - Pre-Combat Checks .....	I-9
Task 3 - Perform Launcher Start Up Procedures .....	I-9
Task 4 - Conduct Launcher Calibration .....	I-10
<i>Phase III. OCCUPATION</i> .....	I-11
Task 5 - Occupy an OPAREA .....	I-11
Task 6 - Input Masking Data .....	I-11
<i>Phase IV. FIRING OPERATIONS</i> .....	I-12
Task 7 - Enter MET Data .....	I-12
Task 8 - Execute a Fire Mission .....	I-12

	page
Task 8a - Execute a Manual Fire Mission (FWR) .....	I-12
Task 8b - Execute a Digital Fire Mission (AMC) .....	I-13
Task 8c - Execute a Digital Fire Mission (TOT) .....	I-14
Task 9 - Perform a Reload Operation .....	I-15
<i>Phase V. EMERGENCY PROCEDURES</i> .....	I-16
Task 10 - Perform Hangfire Procedures .....	I-16
Task 11 - Perform Emergency Destruction .....	I-16
<i>Phase VI. AFTER ACTION REVIEW</i> .....	I-17
General .....	I-17
Present Formal Results .....	I-17
Discuss Mistakes .....	I-17
Use Appropriate Training Aids .....	I-17
Summary and Questions .....	I-17
<b>APPENDIX J. SAFETY</b>	
<i>Section I. RESPONSIBILITIES AND PROCEDURES</i> .....	J-1
Responsibilities .....	J-1
Procedures .....	J-2
<i>Section II. COMPUTATION OF SAFETY DATA</i> .....	J-3
General .....	J-3
Definition of Terms .....	J-3
Firing Point Method .....	J-5
OPAREA Method .....	J-7
<b>APPENDIX K. BALLISTIC ALGORITHM TABLES</b>	
M26 and M28 Rocket Ballistic Algorithm Solutions .....	K-1
M28A1 Rocket (Reduced Range, Practice) Ballistic Algorithm Solutions .....	K-19
<b>GLOSSARY</b> .....	Glossary-1
<b>REFERENCES</b> .....	References-1
<b>INDEX</b> .....	Index-1

## PREFACE

---

This publication is designed primarily for the multiple launch rocket system (MLRS) battalion, battery, and platoon. It also is a guide for corps artillery, field artillery brigade, heavy division artillery, Marine artillery regiments, and their staffs, and fire support coordinators and their supported commanders and staffs. This publication sets forth the doctrine pertaining to the organization, equipment, command and control, operations, and tactics, techniques, and procedures for the MLRS battalion, battery, and platoon. It establishes the responsibilities and general duties of key personnel by focusing on essentials of how the MLRS unit fights. It keys the MLRS battalion, battery, and platoon leaders to those areas that must be trained to win the fight. The specifics of how we train to fight are outlined in soldier's manuals and Army training and evaluation program (ARTEP) mission training plans (MTPs).

This publication is compatible with Army Operations doctrine as outlined in FM 100-5. It does not stand alone. It should be used with equipment technical manuals, soldier's manuals, and trainer's guides. It is designed to be used with the FM 6-20 series, FM 71-3, FM 71-100, FM 100-15, FMFM 2-7, FMFM 4, FMFM 6, FMFM 6-9, and FMFRP 6-17.

Tables of Organization and Equipment (TOE) 06466L000, 06467L000, and 06398L000 are based on the doctrinal tactics, techniques, and procedures (TTP) outlined in this publication. The approved TOEs detail manpower and equipment authorizations for United States (US) Army units. Some of the required positions outlined in Chapter 2, however, may be unresourced. Additionally, all Army units are organized under modification tables of organization and equipment (MTOEs). To determine manpower and equipment authorizations for a specific unit, refer to the authorization document (MTOE) for that unit.

This publication implements quadripartite standardization agreements [QSTAGs] 217, 269, and North Atlantic Treaty Organization [NATO] standardization agreement [STANAG] 2934 (Chapters 3 and 11).

QSTAG 217, Edition 2, (*Tactical Tasks and Responsibilities for Control of Artillery*).

QSTAG 269, Edition 1, (*Survey Accuracy Requirements for Surface-to-Surface Artillery*).

STANAG 2934, Edition 1, (*Artillery Procedures, Chapters 3 and 11*).

The proponent of this publication is HQ TRADOC. Send comments and recommendations on DA Form 2028 (Recommended Changes to Publications and Blank Forms) directly to:

**Commandant  
US Army Field Artillery School  
ATTN: ATSF-GR  
Fort Sill, Oklahoma 73503-5600.**

Unless this publication states otherwise, masculine nouns and pronouns do not refer exclusively to men.

## CHAPTER 1

## SYSTEM DESCRIPTION

*This Chapter Implements QSTAG 269 and STANAG 2934, Chapter 11.*

The multiple launch rocket system is a highly mobile, rapid-fire, surface-to-surface, free-flight rocket and guided missile system. It is designed to complement cannon artillery; to attack the enemy deep; and to strike at counterfire, air defense, and high-payoff targets. It can supplement other fire support systems by engaging a dense array of mechanized targets during surge periods. The MLRS battalion is a corps asset and can be attached to a field artillery (FA) brigade or to division(s) within the corps. The MLRS battery is organic to armored and mechanized infantry divisions. Light infantry divisions may receive MLRS support from corps assets.

---

 Section I  
 INTRODUCTION
 

---

### MLRS Employment Concept

The capabilities of MLRS make it one of the most versatile FA weapon systems available for both joint and combined arms operations. Its range, mobility, and lethality allow it to execute the full spectrum of fire support -- providing close support to maneuver units, protecting the force with counterfire, and attacking operational targets for the division, corps, Marine air-ground task force (MAGTF), or joint task force commander and in support of theater missile defense (TMD).

Regardless of the tactical mission, MLRS units are positioned and fight well forward and use their shoot-and-scoot capability to improve survivability. Forward positioning is critical to accomplishing these deep missions. When providing close support in the offense, MLRS units move with the maneuver forces they support, stop to fire as required, and then move rapidly to rejoin the formation. In the defense, these systems support maneuver units by moving laterally along the forward line of own troops (FLOT). This allows MLRS units to take maximum advantage of their range to protect maneuver units from the destructive effects of the enemy's indirect fire systems. The mobility and massive firepower of the MLRS make it well-suited to augment other artillery fires supporting cavalry units engaged in operations such as screening, covering force, and movement to contact.

The 32 kilometer (km) range of the MLRS rocket and the 165 km range of the Army tactical missile system (Army TACMS) provide the division, corps, MAGTF, and joint commanders with a deep strike option. To support deep operations, MLRS units are positioned close to the FLOT and in some cases beyond the FLOT to engage the enemy

at maximum ranges and to continue to attack him throughout the depth of the battlefield. The MLRS units assigned the mission of firing Army TACMS in support of a joint force commander's deep operation will often operate in a maneuver brigade area of operations. Intermixed with maneuver and cannon units, these MLRS units will find themselves continually coordinating for positions within the maneuver brigade sector.

The MLRS plays a critical role in contingency operations because it provides a massive infusion of combat power in small, rapidly-deployable force packages. The extreme lethality of the MLRS family of munitions (MFOM), coupled with the air deployability of the system on a variety of aircraft, makes MLRS units the logical choice to deep fires for initial entry forces.

### System Components

The multiple launch rocket system consists of the components described below.

#### M270 Launcher

Each launcher has the onboard capability to receive a fire mission, determine its location, compute firing data, orient on the target, and fire. Each bay of the launcher must be loaded with the same type munition. Once laid and armed, the launcher can fire:

- Twelve rockets in less than 60 seconds at up to six aimpoints.
- Two missiles in less than 20 seconds at one or two aimpoints.

**Launch Pod/Containers and Guided Missile Launch Assemblies**

Each launch pod container (LPC) holds six rockets, and each guided/missile launch assembly (GMLA) holds one missile. The pods are stenciled with the DOD identification code (DODIC). This is the same code that is displayed on the fire control panel (FCP) when ammunition status is displayed to the M270 crew members.

**Ammunition Resupply Vehicles and Trailers**

The ammunition resupply capability for MLRS is provided by the heavy expanded mobility tactical truck (HEMTT) M985 and the heavy expanded mobility ammunition trailer (HEMAT) M989/M989A1. Each one

can carry four rocket/missile pods for a total of 48 rockets or eight missiles in a HEMTT and HEMAT load (the HEMAT M989 is limited to two launch pods during peacetime operations, but the HEMAT M989A1 does not have this limitation).

**Command, Control, and Communications System**

The MLRS has an automated command, control, and communications (C3) system to provide command and control of subordinate launchers and to facilitate communication on the battlefield. Major components of the C3 system are the fire control system (FCS), located in the launcher, and the fire direction system (FDS), located at the platoon. Only selected batteries and battalions have the fire direction data manager (FDDM).

---

Section II  
**LAUNCHER AND SUBSYSTEMS**

---

**M270 Launcher**

The M270 launcher is a highly mobile, lightly armored, tracked carrier vehicle with a launcher-loader module (LLM) mounted on the vehicle bed (see Figure 1-1). The launcher consists of a three-man crew (section chief, gunner, and driver). Personal equipment is stored in the crew's equipment storage containers located in the carrier under the LLM cage. References are listed at the back of this publication.

The M270 launcher has two major configurations. The US has a system that can fire rockets and missiles; the memorandum of understanding (MOU) nations have M270 launchers which can only fire rockets. The difference between them is the payload interface module (PIM), a new stabilization reference package/position determining system (SRP/PDS) and software special applications packages (SPAPS).

**M993 Carrier Vehicle**

The carrier vehicle is a longer version of the Bradley fighting vehicle with nearly 80 percent common components. It is 6.3 meters (m) (22 feet [ft] 11 inches [in]) long, 2.6 m (8 ft 6 in) high, and 2.97 m (6 ft 9 in) wide. When heaviest (loaded with M26 rocket LPCs), the launcher weighs approximately 24,036 kilograms (kg) (52,990 pounds). It can climb 60 percent slopes, traverse a 40 percent side slope, ford 1.1 m (40 in) of water, and climb 1 m vertical walls. The launcher has a cruising

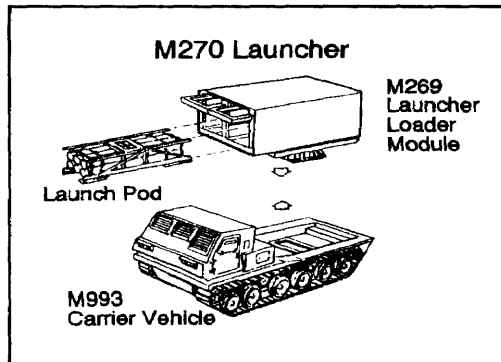

**Figure 1-1. M270 launcher.**

range of 483 km (300 miles) and can be transported by C-141B and larger cargo aircraft (see Appendix A).

The vehicle cab is constructed of aluminum armor plate, providing ballistic protection to the crew. It is fitted with an M13A1 gas particulate filter unit that protects the crew from chemical and biological agents and radioactive particles. It also has a vehicle cab overpressure system to protect the crew from toxic rocket and missile exhaust.

**M269 LLM**

The LLM consists of two sections--a mechanical section and an electrical section. These sections work together in order to perform all firing and non-firing functions.

## LLM Mechanical Section

The mechanical section consists of base, turret, and cage assemblies. The base assembly provides for the physical mounting of the LLM to the carrier. Both the turret and base assemblies house the electronics and hydraulics of the launcher drive system (LDS) that actually perform the rotation and elevation functions the LLM. The cage assembly performs two important functions. First, the structure of the cage assembly aligns, holds, and protects the launch pods. Second, two boom and hoist assemblies mounted in the cage assembly give the launcher crew a built-in ammunition loading and unloading capability.

## LLM Electrical Section

The electrical section consists of three subsystems: the primary power supply, the communications system, and the FCS.

**Primary Power Supply.** The primary power supply is the source of power for all launcher equipment. It uses standard military lead acid batteries to provide 24 volts of power to the launcher components. It also controls the distribution of power through the use of switching relays.

**Communications System.** The launcher communications system includes a secure -12 series frequency modulated (FM) radio and one communications mode selector control (CMSC) device or the newer single-channel ground and airborne radio system (SINCGARS) AN/VRC-92A radio system with embedded communications security (COMSEC) capability. The CMSC detects an incoming signal, determines whether it is digital or voice traffic, and automatically routes it to the secure FM radio in the proper mode for decryption. The CMSC is not required if using SINCGARS with embedded COMSEC. Each crew member has a combat vehicle crewman (CVC) helmet that is connected to an AN/VIC-1 intercom system.

**Fire Control System.** The FCS functions with the other launcher components to provide overall control of the LLM. It monitors, coordinates, and controls all electronic devices used during a launch cycle. The FCS consists of the fire control panel (FCP), electronics unit (EU), fire control unit (FCU), boom controller (BC), short/no-voltage tester (SNVT), SRP/PDS, PIM, program load unit (PLU), and communications processor (CMP).

- **Fire Control Panel.** The FCP, located in the center of the carrier cab in front of the gunner's seat, has a data entry keyboard for manual entry operations and for message menu selection. The panel also gives alphanumeric displays in simple language.

Next to the data keys are built-in test (BIT) indicator lamps for line replaceable units (LRU). These allow rapid detection and isolation of faults in the FCS.

- **Electronics Unit.** The EU contains the computer program and data processing electronics to receive, compute, and distribute fire mission parameters. The EU holds all current weapon files and operational data for the launch and ballistic computation programs in its "bubble" memory (permanent, nonvolatile). However, only those munition programs which have been moved into the EU random access memory (RAM) can be used by the launcher FCS to compute launch and other fire mission data. The EU automatically identifies munition type and copies necessary weapons files from bubble to RAM. If the proper software is not loaded, the crew can then use the PLU to load required munition data into the EU.
- **Fire Control Unit.** The FCU contains the electronic circuits that change the EU outputs into control signals for other launcher components. It also takes inputs from the other components and changes them into signals the EU can use.
- **Boom Controller.** The boom controller permits remote control of the loading and off-loading functions and positioning of the LLM for maintenance.
- **Short/No-Voltage Tester.** The SNVT is a built-in test device used during loading operations. It is used to test the FCS W19 umbilical cables for stray voltage or static electricity. The test ensures that the cables are safe to connect to the loaded launch pods.
- **Stabilization Reference Package/Position Determining System.** The SRP/PDS is composed of two integrated subsystems that are housed in separate compartments; the SRP and the PDS. The SRP uses an electrically driven north-seeking gyrocompass. The SRP provides heading, elevation, and launcher slope. The PDS uses two encoders on the vehicle final drives and orientation data from the SRP to determine position location.
- **Payload Interface Module.** The PIM provides communications power and interface between the loaded launch pods and the EU. Initial input of the EU munitions programs require use of the PLU and the PIM.
- **Communications Processor.** The CMP controls the flow of the digital coded audio tone

messages sent and received by the launcher communications-FCS interface. It is designed to ensure the FCS does not acknowledge, nor allow itself to be disrupted by, digital messages not addressed to that launcher. It also rejects any weak or garbled signals.

**Program Load Unit.** The PLU is an electronic device used to program the EU memory (see Figure 1-2). The PLU mounts a cassette containing operational program data. The PLU is connected to the EU through the PIM interface connector W31P2 using PLU cable assembly. When the FCS is turned on, the PLU downloads the data on the cassette into the EU memory. Each cassette has 4 megabytes (MB) of memory. The PLU is used to access specific munition programs on the cassettes. The hand-carried PLU issued to the firing platoons is used to program or change the current programming of the launcher EU. The PLU requires at least 22-25 minutes to transfer an entire cassette of data.

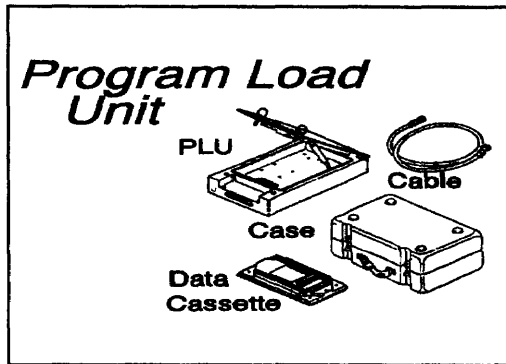

Figure 1-2. Program load unit.

### FCS Functions

The launcher FCS provides the link between the crew, external digital message sources, and the launcher components. It performs the following significant functions:

- Monitors and integrates all onboard sensor data.
- In conjunction with the launcher communications system, provides a digital interface between the launcher crew and the command and control elements.
- Monitors the status of built-in tests.
- Enables the crew to control launcher components.

- Computes firing data for all fire missions.
- Lays the LLM and sets fuzes or programs warheads as required.
- Controls LLM operations.

The FCS receives data input in the following ways:

- Current mission data are input automatically through digital coded audio tone radio messages or manually through the FCP keyboard.
- The EU munitions programs are input from a cassette through a PLU.

Data communication is the most common and preferred method of input to the FCS. Through radios, the FCS can communicate digitally with the platoon FDS or the battery/battalion FDS/FDDM. The FCS can receive MLRS and MET category formats as well as the SYS;PTM message. Secure data digital communication between TACFIRE, the initial fire support automation system (IFSAS), the light TACFIRE (LTACFIRE), or the Marine Corps Fire Support System (MCFSS), and a launcher FCS must be routed through an FDS/FDDM, because message formats are not compatible. The FCS allows the crew to send and receive fixed-format messages and to receive free-text messages.

The primary means of communication is FM secure data, however, FM voice secure communication is available as a backup. In case of data communication failure or when operating voice, the crew can manually enter all data elements through the FCP keyboard.

The EU automatically monitors, integrates, and computes data from other FCS launcher electronic components. It continuously monitors the SRP/PDS data and computes launcher heading (travel direction), location, and altitude. The FCS determines the firing data when the target information is received. When the crew enters the appropriate mission command, the FCS commands the LLM to lay on the required launch azimuth and elevation, and sets the rocket fuze times or programs the warheads. The FCS fires the rockets or missiles when commanded by the gunner through the FCP.

The FCS continuously checks its internal components and those of the LLM. These checks are made throughout the mission cycle. If a malfunction is detected, the crew members are notified by an error warning message or LRU/BIT displayed on the FCP.



The FCS can currently operate in five different language formats: US-English, UK-English, German, French, and Italian.

**Note:** The launcher is unable to fire the mission if a malfunction occurs in a launcher FCS; that is, in the FCP, EU, FCU, or SRP/PDS. Since no backup means exist to fire the launcher manually, the fire mission must be redirected to an operational launcher for completion.

---

### Section III

## MLRS FAMILY OF MUNITIONS (MFOM)

---

### Launch Pod

#### Description.

Each M270 holds either two LPCs or two GMLAs (not a mix of the two) in the LLM (see Figure 1-3). Each launch pod contains either six rocket tubes or one missile housing in a containerized shipping, storage, and launch frame. Rockets and missiles are factory assembled and tested. Rockets are stored in fiberglass containers; missiles are stored in an aluminum enclosure with fiberglass camouflage panels on the exterior. Both rockets and missiles are then mounted on the frame. Both the rocket tubes and the missile housing are connected by cable to common electrical connectors. Not only are handling, transport, and loading fixtures similar, the LPC and GMLA are also visually similar.

The launch pod is 4.04m (13 ft 2 in) long (without skids) and 1.05 m (3 ft 5 in) wide. The height of the pod is 0.84 m (2 ft 9 in) with skids and 0.72 m (2 ft 4 in) without skids. When loaded with rockets (tactical or practice), each LPC weighs 2,270 kg (5,005 pounds). A loaded GMLA weighs 2,095 kg (4,609 pounds), and an inert training GMLA weighs 1,360 kg (2,998 pounds).

Four aluminum bulkheads provide rigidity to the frame and support for the rocket tube or missile housing. Tie-down and lifting D-rings are located on the top of the frame at the four corners. A lifting rod is installed for lifting the container by the launcher boom and hoist assemblies.

Stacking pins at the top four corners of the frame permit stacking of the launch pods. They can be stacked two high during transport and four high during storage. They can

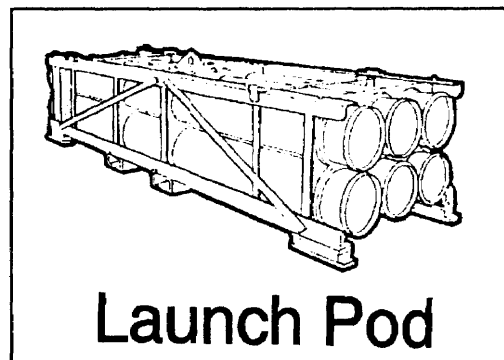

**Figure 1-3. Launch pod.**

be handled by forklift, since they have two inner bulkheads that serve as support members. Each launch pod is marked for the center of gravity and proper lift areas.

The detachable skids mounted to the bottom four corners of the frame must be removed from the pod before it is loaded into the LLM. A quick-release pull pin allows easy removal of the skids. The GMLA also has a lifting rod cover which must be removed before being loaded into the LLM.

The changing of rocket and missile pods requires a repositioning of the loading hoist assembly system.

### Rockets

The MLRS rockets are tube-launched, spin-stabilized, free-flight projectiles. The rockets are assembled, checked, and packaged in a dual-purpose launch-storage tube at the factory. This design provides for tactical loading and firing of the rocket without troop assembly or detailed inspection. Major components of the rocket assembly include four stabilizer fins, a propulsion section, and a warhead section. (See Figure 1-4, page 1-6.)

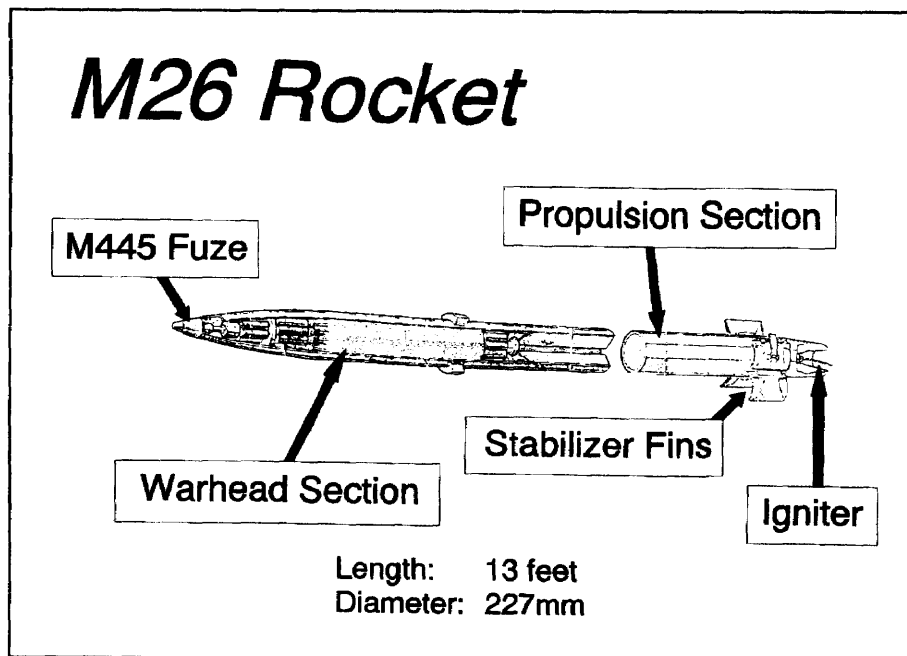

Figure 1-4. M26 rocket.

Propulsion for the rocket is provided by a solid propellant rocket motor. An umbilical cable, passing through the aft end of the launch tube, links the FCS to an igniter in the rocket nozzle. The motor is ignited by an electrical command from the FCS.

Each rocket is packaged with the four fins folded and secured by wire rope retaining straps. As the rocket moves forward upon firing, lanyard devices trigger a delayed strap-cutting charge. After the rocket leaves the launch tube, the charge cuts the straps. This allows the fins to unfold and lock. The M28 and M28A1 rockets' LPCs have an additional fin release device to ensure deployment.

The MLRS rocket follows a ballistic, free-flight (unguided) trajectory to the target. The propulsion provided by the solid propellant rocket motor is the same for each rocket, so rocket range is a function of LLM elevation. The four stabilizer fins at the aft end of the rocket provide in-flight stability by maintaining a constant counterclockwise spin. The initial spin is imparted to the rocket through spin rails mounted on the inner wall of the launch tube.

### M26 Rocket

This is the basic rocket for MLRS. It is used against personnel, soft and lightly armored targets normally with a target location error (TLE) of 150 m or less. Larger

TLEs may reduce effectiveness. Each rocket dispenses 644 M77 dual-purpose improved conventional munitions (DPICM) submunitions over the target area.

### M26 Warhead Function

Warhead event is initiated by an electronic time fuze (M445) that is set remotely by the FCS immediately before ignition of the rocket motor. The fuze triggers a center burster charge. This causes the warhead to rupture, the polyurethane filler to shatter, and the submunitions to be spread over the target area.

### M77 Submunition Description

The armed M77 submunitions detonate on impact (see Figure 1-5). The antimateriel capability is provided through a shaped charge with a built-in standoff. The M77 can penetrate up to four inches of armor. Its steel case fragments and produces antipersonnel effects with a radius of 4 m.

This rocket can attack targets at ranges between 10-32 km. Although system software allows firing at ranges as short as 5 km, the submunition dud rate increases significantly at ranges less than 10 km.

### M28 Rocket (Training)

The M28 rockets are available for live firing at Army training installations. This practice rocket has the same

flight characteristics as the M26 rocket. It has a spotting charge of three smoke canisters and steel ballast rods rather than submunitions.

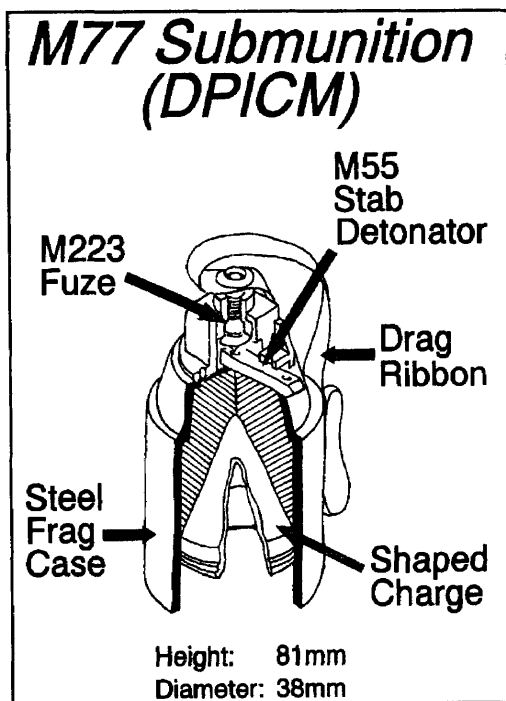

Figure 1-5. M77 submunition.

**M28A1 Rocket (Training)**

The M28A1 rocket (reduced range) is also available for live firing at Army training installations. This practice rocket has a monolithic (relatively uniform and predictable) trajectory and a reduced range (8-15 km). This results in a much smaller surface danger area (SDA) than the M28/M26, thus allowing it to be fired on many tube artillery firing ranges. It has a blunt nosed, high-drag warhead section which contains an impact activated smoke charge. It has the same motor assembly as the M26/M28.

**Missiles**

The Army TACMS missiles are ballistically launched, inertially guided missiles. They are designed to carry a variety of submunitions, to include "smart" munitions and lethal mechanisms to provide a wide range of future capabilities. Currently, the Army has only the M39 missile.

**Missile Assembly**

The missile has four sections: the guidance and control section, propulsion section, control section, and the warhead assembly (see Figure 1-6).

**Guidance and Control Section (GCS).** The GCS provides all navigation, guidance, autopilot, and internal communications functions for the Army TACMS missile

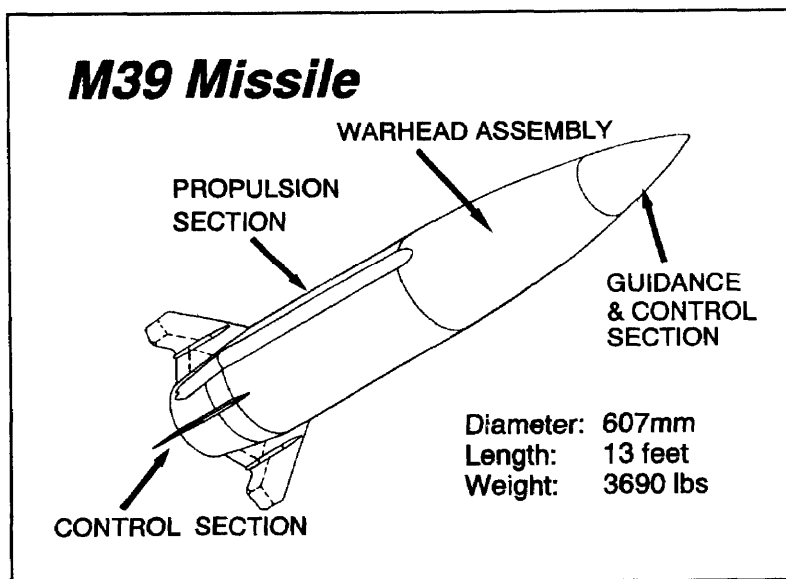

Figure 1-6. M39 missile.

while in flight and for all ground operations. Continuous determination of position, attitude, and motion are provided by the inertial sensors, associated electronics, and software processing. Guidance and autopilot functions are provided by software processing within the GCS computer. All communications, both internal and external to the missile (missile to launcher and/or ground support equipment), are provided by the GCS electronics and software. This includes communications with the M270 FCS electronics for launch control, the ground support equipment for maintenance, and the control system electronics unit (CSEU) for missile fin actuator control.

**Propulsion Section.** The solid rocket motor furnishes the energy necessary to launch the missile and sustain missile flight for a sufficient time to meet Army TACMS altitude and range requirements. The solid rocket motor consists of a motor case, propellant, insulation/liner, nozzle, and igniter arm/fire assembly.

**Control Section.** The primary functions of the control section assembly are to position the missile fins, provide the missile electrical power while in flight, and support selected pyrotechnic functions.

**Warhead Assembly.** The primary function of the warhead assembly is to carry, protect, and dispense the missile payload. The warhead assembly consists of a rolled aluminum shell with aluminum support structures and front and rear bulkheads. A center tube connects the bulkheads and provides a central wire route. In addition to the payload, the warhead assembly contains a skin severance system which controls the release of the payload at the required time.

**M39 Missile Warhead**

This warhead is used against personnel and soft targets normally with a TLE of 150 m or less. Larger TLEs may reduce effectiveness. Each missile dispenses a cargo of approximately 950 antipersonnel and antimateriel (APAM) M74 grenades over the target area. The M39 missile (Army TACMS Block I) has a minimum range of 25 km and a maximum range of 165 km.

**M39 Warhead Function.** Warhead event is initiated by an electronic time fuze (M219A2) that is set in the same manner as the M445 electronic time fuze of the M26 rocket. The fuze detonates shaped charges mounted to the skin and bulkheads. This in turn severs the skin. By means of centrifugal force and airstream currents, the M74

grenades are distributed over the target area. Arming of the M74 grenades is accomplished by the spin action which is induced on the individual grenade.

**M74 Submunition Description.** The M74 grenade is filled with composition B explosive filler and is covered by a steel shell (see Figure 1-7). Upon impact and detonation each grenade breaks up into a large number of high-velocity steel fragments that are effective against targets such as truck tires, missile rounds, thin-skinned vehicles, and radar antennas. This submunition is not effective against armored vehicles. The M74 grenade also contains incendiary material and has an antipersonnel radius of 15 m.

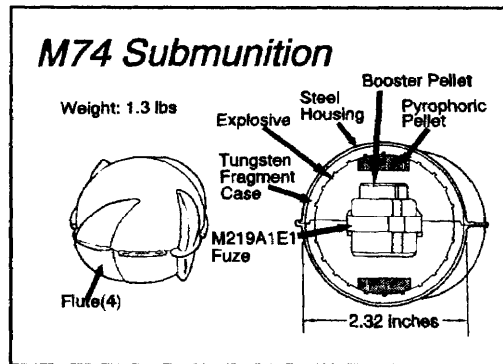

Figure 1-7. M74 submunition.

**Future Developmental Munitions**

**Rockets**

**Extended Range Rocket.** The extended range (ER) rocket is an evolution of the basic M26 rocket that extends the range to 45-plus km. This greater range capability is achieved through a 20 percent reduction in the number of submunitions and a modified rocket motor. It has at least the same accuracy as the basic M26 rocket. ER-rocket accuracy is enhanced by an improved rocket detent located in the launch tube. Additionally, the wind measuring device (WMD), a component of the future Improved FCS, updates the firing solution prior to launch at the firing point with corrected low level wind readings. The effectiveness of the M26 rocket is maintained in the ER-rocket even though the submunition payload has been decreased. This is due to the improved center core burster and a reduction in the dud rate, made possible by an improved drag ribbon design and the incorporation of a self-destruct fuze.

**MLRS Smart Tactical Rocket (MSTAR).** MSTAR will be a robust smart munition warhead primarily employed against counterfire targets, but with capabilities to attack other moving or stationary, hot or cold targets. The munitions will be delivered by the ER MLRS rocket. MSTAR will provide the division commander with a highly responsive, fire-and-forget engagement capability against a wide variety of targets of tactical depth. MSTAR will offer greater lethality with reduced logistical burdens, minimize effects of huge target location errors, and reduce collateral damage.

**Extended Range Rocket (Guided).** Low cost guidance for MLRS rockets seeks to integrate a guidance and control system into the ER MLRS to provide much improved delivery accuracy (2-3 mil circular error probable [CEP]). The demonstrated system will be designed to allow for the inclusion of a global positioning satellite (GPS) receiver and antenna in order to be postured for any future requirement in which very accurate (5 meter CEP) delivery errors maybe required. Guidance for MLRS will significantly improve the effectiveness of both DPICM and precision guided submunition payloads while reducing logistics burdens, mission times and collateral damage.

### Missiles

**Army TACMS Block IA.** The Block IA missile carries approximately 300 M74 bomblets. A GPS receiver will be integrated into the missile which allows it to receive positioning data updates for increased accuracy. The Block IA missile ranges targets from 100 to 300 km.

**Army TACMS Block II.** Block II employs the brilliant antiarmor technology submunition (BAT) (see Figure 1-8). The Block II missile ranges targets from 35 km to 140 km. The Block II payload consists of thirteen BAT

submunitions which are equipped with both acoustic and infrared sensors that give each submunition the capability of acquiring and attacking moving armor targets. After the dispense from the main warhead, each BAT submunition autonomously seeks an individual target within a moving armor column with its acoustic sensor. Once each submunition is close enough to its selected target vehicle, the inbred seeker is activated and provides guidance during the terminal trajectory. The BAT submunition has a tandem shaped charge warhead designed to defeat all known reactive armor.

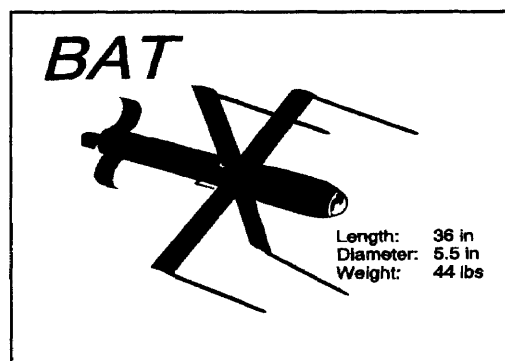

Figure 1-8. BAT submunition.

**Army TACMS Block IIA.** Block IIA employs an improved BAT submunition that is effective against both hard and soft, moving and stationary targets. The Block IIA payload consists of six improved BAT submunitions which are equipped with sensors that give each submunition the capability of acquiring the target regardless of whether an inbred signature exists. The improved BAT submunition has a multipurpose design to kill both hard and soft targets at ranges that exceed the Block II missile.

*This section implements QSTAG 269 and STANAG 2934, Chapter 11.*

## Section IV ASSOCIATED EQUIPMENT

### Ammunition Resupply Vehicle and Trailer (HEMTT/HEMAT)

The M985 HEMTT is a 10-ton, 8-wheel or 8-wheel-drive truck with a 5,400-pound lift capacity materiel-handling

crane (see Figure 1-9, page 1-10). A secure FM radio provides voice command and control capability. The rear-mounted crane can traverse 360° to the left or right. Both the HEMTT and the HEMAT can be loaded and unloaded with the crane. The HEMAT does not have to be unhooked from the HEMTT. The truck carries four launch pods with a gross vehicle weight of 59,000 pounds.

## FM 6-60

Its operating range is 300 miles, and it can climb a 30 percent slope. The HEMTT has a 445-horsepower diesel engine with an automatic transmission. It can be transported by C-130 and C-141B aircraft in an unloaded configuration and by C-5A/C-5B aircraft in a loaded tactical configuration. (See Appendix A.)

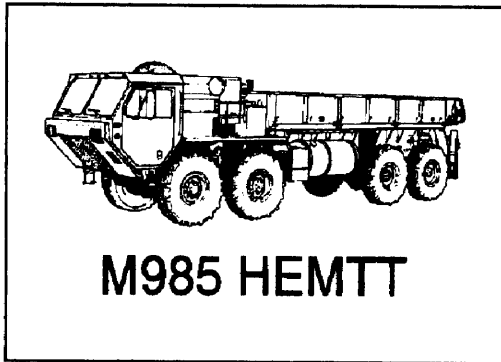

Figure 1-9. M985 HEMTT

The M989A1 HEMAT can carry four launch pods and has a fully loaded gross weight of 31,000 pounds (see Figure 1-10). The trailer can be towed by a launcher in an emergency.

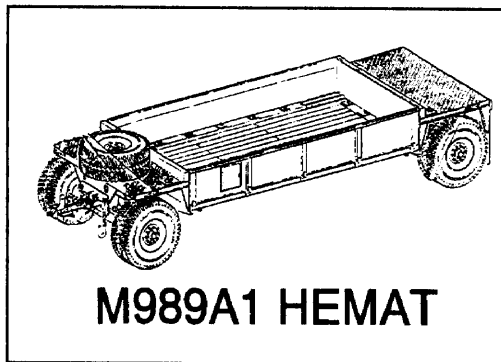

Figure 1-10. M989A1 HEMAT.

### Command, Control and Communications System

Tactical command and control and technical fire direction of MLRS units is provided through a C3 system. The C3 system includes the radio system, FED, FCS, FDS, and in some units, the FDDM. This system is designed to be integrated with several Army and Air Force command, control, communications, and intelligence (C3I) systems to optimize fire support system employment and effectiveness. The MLRS C3 system also can be used to conduct and execute command and control without

external C3 input during independent operations. This independent C3 capability exists at battalion, battery, and platoon levels. The hub of the MLRS C3 system is the MLRS FDS and FDDM. The FDS/FDDM can communicate digitally with the following systems:

- M270 FCS.
- The Tactical Fire Direction System (TACFIRE, LTACFIRE, and MCFSS).
- The Advanced Field Artillery Tactical Data System (AFATDS).
- Firefinder Radar (AN/TPQ-36 and AN/TPQ-37).
- Meteorological Data System (MDS).
- Meteorological Measuring Set (MMS).
- Initial Fire Support Automated System (IFSAS).
- The Forward Entry Device (FED).

### Fire Direction System

The MLRS Fire Direction FDS provides tactical fire direction and data communications for command and control at the MLRS platoon, battery, and battalion. Initialization procedures define the FDS capabilities for the specific echelon. The FDS (AN/GYK-37) consists of the lightweight computer unit (LCU), tactical communications interface module (TCIM), the AC/DC converter/charger, the TCIM wireline adapter, and the printer (see Figure 1-11).

#### Components

**Lightweight Computer Unit.** The LCU is the computer for the FDS. It receives, stores, processes, displays, and transmits tactical and firing data.

**Tactical Communications Interface Device.** The TCIM provides the interface between the LCU and the communications devices.

**AC/DC Converter/Charger.** This device converts the vehicle DC power to proper levels for the FDS computer.

**TCIM Wireline Adapter.** This device interfaces wire from a tactical communications transmitter to either the internal TCIM or the external TCIM.

**Printer.** The printer prints incoming, outgoing, and/or displayed messages as selected by the operator.

**TACFIRE Interface Device (TID).** This device allows the TCIM to use the multiple subscriber equipment.

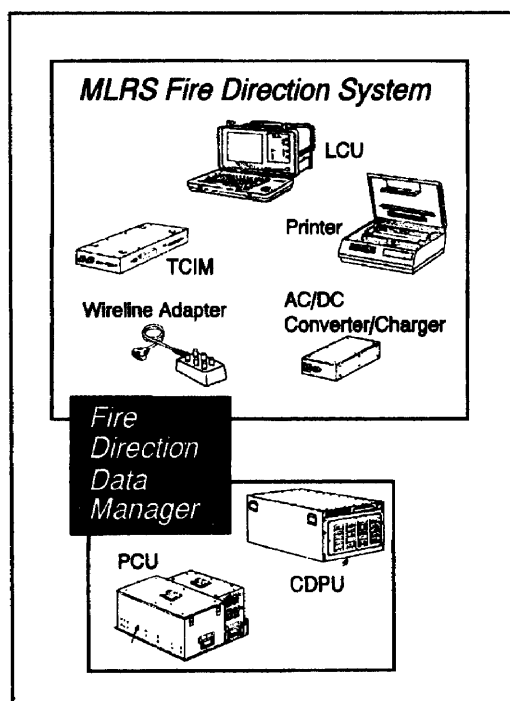

**Figure 1-11. MLRS fire direction system.**

### Characteristics

The FDS has the following capabilities:

- Receives, transmits, and stores data.
- Accepts data input from the keyboard.
- Communicates in either encrypted or clear modes.
- Relays digital messages between two other subscribers.
- Processes a fire mission in less than two minutes.
- Monitors messages.

### Fire Direction Data Manager

The FDDM is used to enhance the tactical and technical fire direction at both the corps fire support element (FSE)

and FA brigade FCE as well as the MLRS battalion and battery. It supplements the basic FDS with a more robust communications data processing capability.

### Components

The FDDM consists of the basic FDS, a power conditioner unit (PCU), a communications and data processing unit (CDPU), and the PLU described earlier in this chapter.

**Power Conditioner Unit.** The PCU consists of rechargeable batteries and electronic assemblies that interface vehicle or auxiliary power to the FDDM. The PCU provides backup power to the FDDM in the event of loss of input power. It also provides a power status signal to the FDDM. The PCU consists of a vented battery box and a sealed electronics box.

**Communications and Data Processing Unit.** The CDPU consists of two microcomputers and an internal power supply mounted in a common chassis. One microcomputer performs communications modem type functions and distributes all message traffic. The other microcomputer performs database management and tactical fire solutions for fire mission processing, scheduling, capabilities analysis, fire planning and munition selection and technical fire control for special applications (SPAP) munitions processing. The FDDM system can function in a degraded mode with only one microcomputer working. The chassis also contains switches, indicators, and connectors necessary for operation of the CDPU.

### Forward Entry Device

The FED is a small man-packed data communications terminal with limited processing capability. The FED will be employed to compose, edit, transmit, receive, store, and display messages used in the planning and execution of fire support operations. Operational facilities in the MLRS battalion using the FED will be liaison officers, survey sections, battery commanders, and firing platoon leaders.

### Survey Equipment

#### Position Azimuth Determining System (PADS)

The survey section of the MLRS battery is equipped with one position and azimuth determining system (PADS). PADS is a self-contained surveying system that rapidly determines accurate location, azimuth, and altitude. It is

## FM 6-60

operated by two people. This equipment gives the MLRS battery a highly mobile survey capability, MLRS survey operations are outlined in Chapter 4.

### Global Positioning System (GPS)

The precision lightweight GPS receiver (PLGR) is a highly accurate satellite signal navigation set (AN/PSN-11). The set operates as a part of NAVSTAR GPS. Up to five satellites are continuously tracked simultaneously. The AN/PSN-11 has an antenna, keyboard, backlit display, receiver processor unit, and a battery.

It is designed for battlefield use anywhere in the world. It is sealed watertight for all-weather day or night operations.

The PLGR is held in the left hand and operated with the left-hand thumb. Capability is included for installation in ground facilities, and air, sea, and land vehicles. The AN/PSN-11 is operated standalone using prime battery power and an integral antenna. It can be used with an external power source and external antenna (see Figure 1-12).

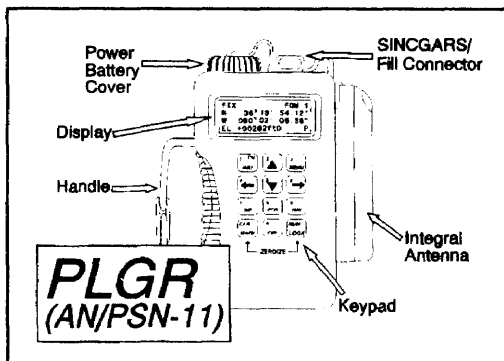

Figure 1-12. PLGR AN/PSN-11.

GPS receivers rely on electronic line of sight with the satellites. Dense foliage, buildings, mountains, and

canyons will mask the signal. All GPS receivers automatically try to track visible satellites as low as 50 above the level horizon. Each receiver has a function which displays the direction and vertical angle to the satellite. This display indicates if masking is a problem. When a satellite signal is masked, move to another location if another satellite is not visible.

Multipath (reflected signals) may occur if the GPS antenna is tilted away from a satellite. This may cause a reflected signal from the satellite to be received that has more signal strength than the direct signal, causing several hundred meters of position error.

The PLGR is only useful for position control for MLRS when it provides a figure of merit (FOM) of 1. The FOM is a number from 1 to 9 located in the upper right portion of the display which shows the total estimated position error (EPE) as shown in Table 1-1 below.

Table 1-1. Estimated Position Error

FOM Value	Estimated Position Error
1	≤ 25 m
2	≤ 50 m
3	≤ 75 m
4	≤ 100 m
5	≤ 200 m
6	≤ 500 m
7	≤ 1000 m
8	≤ 5000 m
9	> 5000 m



## CHAPTER 2

## ORGANIZATION

**MLRS units are organized and equipped to provide FA missile fires in support of maneuver force and to reinforce the fires of other FA units. The MLRS battalion is usually attached to an FA brigade but may be attached to a division. An MLRS battery (btry) is organic to a heavy division to provide immediately responsive fires to the division commander.**

### Section I STRUCTURE

#### MLRS Battalion

The mission of the MLRS battalion is to provide field artillery medium range rocket and long range missiles fires in support of the corps, army, theater, joint/coalition forces and MAGTFs or in the conduct of TMD to destroy, neutralize or suppress the enemy in accordance with Army Depth and Simultaneous Attack Doctrine. The MLRS battalion is organic to a corps, but normally assigned or attached to a headquarters and headquarters battery (HHB), FA brigade, TOE 06042L 100/L200. It may be further attached to a HHB, division artillery (div arty), Marine Artillery Regiment, to Joint or coalition forces in support of multi-national initiatives or to other controlling headquarters as required.

The MLRS battalion is composed of a headquarters, headquarters and service (HHS) battery and three firing batteries with nine launchers each (see Figure 2-1).

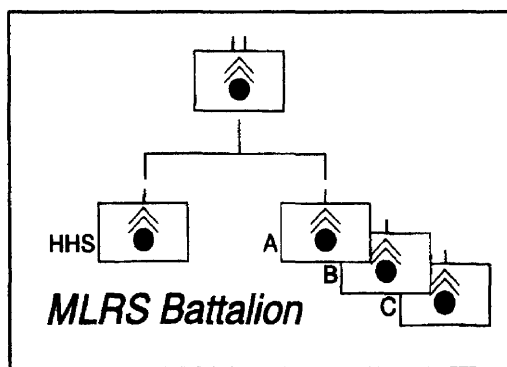

**Figure 2-1. MLRS battalion organization.**

The battalion can operate as a single unit, or it can detach batteries to perform separate tactical missions. The MLRS battalion headquarters may assume control of one or more of its own batteries and of divisional MLRS batteries. In this role, the battalion headquarters may act

as an MLRS controlling headquarters in coordination with the force artillery commander. In heavy divisions, the div arty assumes the role of an MLRS battalion staff in conducting coordination and providing command and control of the divisional MLRS battery.

#### Headquarters, Headquarters and Service Battery

The mission of the HHS is to provide command, control, administrative and service support for organic and attached elements. It is also to procure, distribute, administer and coordinate supply transactions for all classes of supply, and to provide unit maintenance support not within the capabilities of the firing batteries. The HHS is organic to the FA battalion, MLRS TOE 06465L000. The HHS is organized and equipped to coordinate administrative, logistical, maintenance, and communications support for the battalion headquarters and three firing batteries (see Figure 2-2, page 2-2). The functional elements of the HHS are discussed below.

#### Battalion Command Section

The battalion headquarters consists of the battalion commander and his staff: the executive officer (XO), adjutant (S1), intelligence officer (S2), operations officer (S3), battalion (bn) logistics officer (S4), battalion signal officer (BSO), chaplain, and command sergeant major (CSM). This headquarters controls and coordinates battalion activities. Equipment includes two 1 1/4-ton high-mobility, multipurpose wheeled vehicles (HMMWVs) with secure FM radios (one with a AN/VRC-92A and the other with AN/VRC-89A).

#### Battery Headquarters

The battery headquarters is supervised by the battery commander (BC) and the first sergeant (1SG). It includes

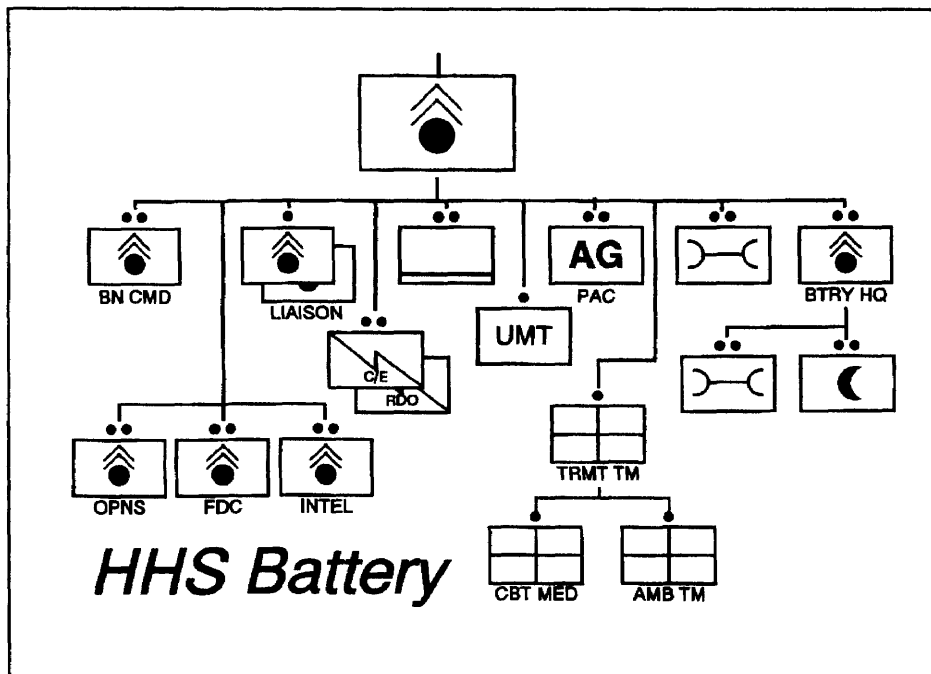

**Figure 2-2. Headquarters, headquarters and service battery.**

the supply sergeant, a decontamination specialist, an armorer, and a driver. It provides command and control and administrative, supply, support to, and coordinates security for the battery. The TOE equipment includes two HMMWVs, one cargo truck, and one secure FM radio (AN/VRC-90A).

### Operations Section

The operations section is supervised by the operations officer. It is staffed with the operations sergeant; a chemical officer; a nuclear, biological, chemical (NBC) noncommissioned officer (NCO); a signal specialist; and a driver. The operations section employs the batteries to meet the needs of the supported units. It develops operational plans, orders, maintains the tactical situation maps, overlays, and coordinates tactical movements and positioning. The equipment includes one armored command post carrier (shared with the intelligence section) with three FM (AN/VRC-92A and AN/VRC-90A) and one AM (AN/GRC-193) secure radio systems, and one HMMWV with a secure FM radio (AN/VRC-90A).

### Fire Direction Center

The fire direction writer is supervised by the battalion fire direction officer (FDO). It is staffed with a chief fire direction computer, a fire direction computer, and four fire

direction specialists. The fire direction center has tactical control over and provides tactical fire direction to the batteries. Equipment includes one armored command post carrier with one AM (AN/GRC-193) and four FM (two each AN/VRC-92A) secure radio systems and MLRS FDS.

### Intelligence Section

The intelligence section is supervised by the S2. It is staffed with the intelligence sergeant and a driver. The intelligence section provides intelligence and security information, develops the priority intelligence requirements (PIR) related to fire support, manages all attached field artillery target acquisition systems as well as Army, joint, and national sensor system down-links under the battalion's operational control, and coordinates with the S3 for survey support for attached target acquisition (TA) assets. The intelligence section processes and correlates targeting data to include predicting artillery target locations and passes this information to the controlling FA headquarters and the battalion FDC. The section monitors enemy artillery tactics and techniques, coordinates the battalion ground and air defense plans with the batteries, and nominates zone coverage, and cueing schedules for all attached radars. Equipment includes one HMMWV with secure FM radio (AN/VRC-90A). This section also uses the armored command post carrier and two of its radio systems organic to the operations section.

### **Liaison Section**

The liaison section is supervised by the liaison officer (LNO). The two teams of the liaison section provide liaison to a reinforced FA headquarters when the battalion is assigned a mission of reinforcing (R) or general support reinforcing (GSR). They also augment existing FSEs if required. Two teams are necessary in order to accommodate frequent changes in tactical mission assignment adequately support joint and coalition forces, and provide liaison when supporting MAGTF operations or conducting TMD. Equipment includes one HMMWV with secure radios (AN/VRC-92A), one PLGR, and one FDS per team.

### **Communications/Electronics (C/E) Section**

The C/E section is responsible for the maintenance and repair of the battalion communications (comm) systems. This section attaches teams forward with firing batteries. Equipment includes four HMMWVs and one secure FM radio system (AN/VRC-90A).

### **Radio Section**

The radio section establishes and maintains the FM retransmission station as required. Dual retransmission capability is essential to maintaining both FM voice and data communications over extended distances. Equipment includes one HMMWV with two secure FM retransmission radio systems (two each, AN/VRC-92A).

### **Personnel and Administration Center**

The battalion personnel and administration center (PAC) is supervised by the battalion S1. It includes a personnel sergeant, a personnel administration supervisor, two clerks, a legal NCO, and a mail delivery clerk. It provides administrative and legal support and helps the battalion commander provide for the welfare of the battalion personnel. Equipment includes a cargo truck, and a facsimile (fax) machine.

### **Unit Ministry Team**

The chaplain's assistant is the only member of the unit ministry team. His mission is to assist the unit chaplain in providing religious services and soldier welfare ministries. Equipment includes a HMMWV with secure FM radio (AN/VRC-90A).

### **Battalion Supply Section**

The battalion supply section is supervised by the S4. It includes a property book officer, a senior maintenance supervisor, a supply sergeant, an assistant supply sergeant, a property book NCO, two petroleum tanker operators, and three supply specialists. The section coordinates the overall supply activities of the battalion and conducts supply operations in support of the HEM. It works closely with the operations section in monitoring the resupply of ammunition and fuel. Equipment includes a cargo truck, a HMMWV with FM radio (AN/VRC-90A), and a HEMTT fuel tanker.

### **Medical Section**

Battalion medical support is provided by the medical section. This section includes the medical treatment team, ambulance team, and combat medic team.

**Medical Treatment Team.** Battalion medical activities are supervised by the battalion physician assistant. The medical treatment team includes an emergency treatment NCO and two medical specialists. The medical treatment team provides sick call, limited medical services, and emergency medical treatment for patients who must be evacuated. Equipment includes two HMMWVs, one secure FM radio (AN/VRC-90A), two chemically and biologically protected shelter systems (CBPS), and medical equipment sets for field trauma, field sick call, chemical agent patient decontamination, and chemical agent treatment.

**Ambulance Team.** The ambulance team consists of one evacuation NCO and an ambulance driver. This team supports the medical treatment team and the firing batteries in medical evacuation. Equipment includes one HMMWV ambulance with FM radio (AN/VRC-90A) and PLGR.

**Combat Medic Team.** This team consists of nine combat medical specialists. One combat medic is allocated per firing platoon. Each medic carries a surgical kit.

### **HHS Food Service Section**

The HHS food service section is supervised by a senior food opns sergeant and includes a first cook and two cooks. The food service section provides food service support to all elements organic or attached to HHS. Equipment includes one cargo truck and a field kitchen trailer.

**Battalion Maintenance Section**

The battalion maintenance section falls under the responsibility of the battalion maintenance officer (BMO). The section includes a maintenance technician, battalion motor sergeant, and adequate mechanics and recovery specialists to provide scheduled maintenance and recovery to HHS (and the firing batteries, if required) and overflow automotive maintenance to firing batteries. The section also coordinates all external maintenance and maintenance supply with the intermediate direct support (DS) unit and maintenance support teams for the battalion. Equipment includes an armored maintenance vehicle, three cargo trucks, a HMMWV, four secure FM radios (AN/VRC-90A), a PLGR, a medium tracked recovery vehicle, and a HEMTT wrecker.

**HHS Battery Maintenance Section**

The HHS battery maintenance section is supervised by the motor sergeant and includes adequate mechanics and repair parts specialists to conduct on-site maintenance and equipment repair. This section maintains the PLL for HEM. Equipment includes a cargo truck and two HMMWVs with one secure FM radio (AN/VRC-88A).

**MLRS Firing Batteries**

The mission of the corps battalion MLRS firing batteries is to provide FA medium range rocket and long range

missile fires in support of the corps, Army, theater, joint or coalition forces and MAGTFs or in the conduct of TMD to destroy, neutralize or suppress the enemy in accordance with Army depth and simultaneous attack doctrine. The corps battalion MLRS firing battery is organic to a FA battalion MLRS, TOE 06465L000 and may be further attached to a HHB, div arty, Marine artillery regiment, to coalition forces in support of multi-national initiatives or to other controlling headquarters as required.

The mission of the divisional MLRS battery is to provide FA medium range rocket and long range missile fires in support of the division and coalition forces to destroy, neutralize or suppress the enemy in accordance with Army depth and simultaneous attack doctrine. The divisional MLRS battery is organic to a heavy division TOE 06300L and is further attached to a HHB div arty to coalition forces in support of multi-national initiatives, or to other controlling headquarters as required.

The MLRS firing batteries are organized similarly, whether assigned to a division or to an MLRS battalion. These firing batteries are structured for independent operations. The MLRS firing battery consists of a headquarters platoon, an ammunition (ammo) platoon, and three firing platoons (see Figure 2-3).

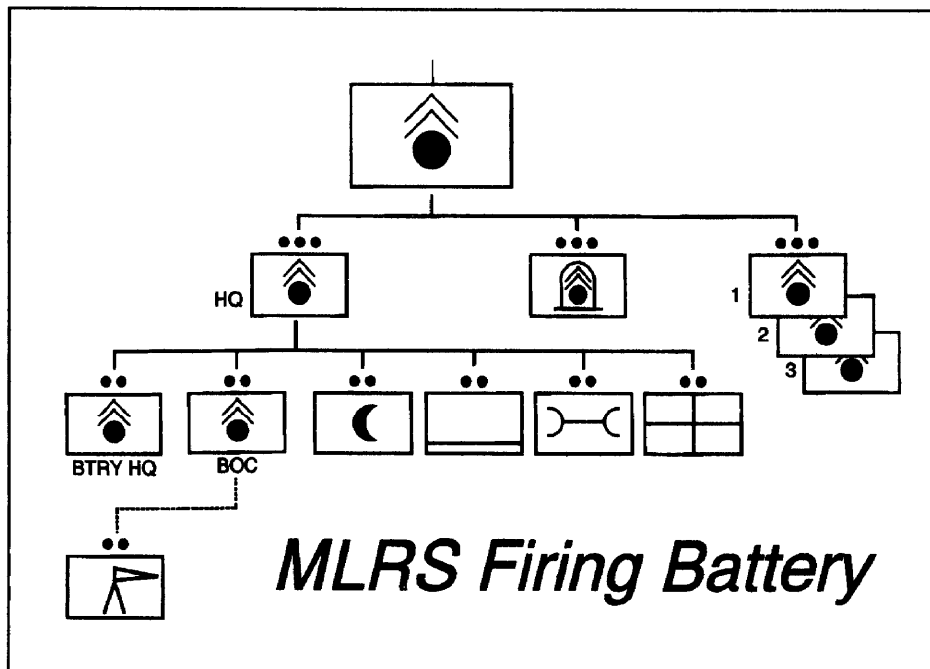

Figure 2-3. MLRS firing battery.

### Battery Headquarters

The battery headquarters (HQ) consists of the commander, 1SG, an NBC NCO, and a vehicle driver. The divisional MLRS battery also has three combat medics and an administrative clerk. The battery headquarters command element (commander and 1SG) and the battery operations center (BOC) provide the necessary C3 and coordination of internal and external administrative and logistical support for the battery. Equipment includes two HMMWVs with secure FM radios (one AN/VRC-89A and one AN/VRC-90A), a FED, and a PLGR.

### Battery Operations Center

The BOC is supervised by the operations officer. It is staffed with a fire direction computer, battery display operator, five fire direction specialists, a signal support systems specialist, and normally, the NBC NCO organic to the battery headquarters. The BOC plans, coordinates, and executes tactical movements, and positioning, maintains situation maps and overlays, and provides tactical fire direction for the battery. Equipment includes an armored command post carrier with one secure AM (AN/GRC-193A) and five secure FM (two AN/VRC-92A and one AN/VRC-90A) radio systems, and one FDS (AN/GYK-37).

### Survey Section

This section consists of the PADS team chief and vehicle driver. It provides all survey support for the firing platoons under the control of the BOC. Equipment includes a HMMWV with FM radio (AN/VRC-90A), and PADS, a PLGR, and a theodolite.

### Food Service Section

The battery food service section consists of a senior food operations sergeant, a first cook, and two cooks. It can draw, prepare, serve, and deliver rations (using the supply section HMMWVs) to the battery headquarters, the firing platoons, and the ammunition platoon. Equipment includes a cargo truck and a field kitchen trailer.

### Supply Section

The supply section consists of the supply sergeant, four petroleum vehicle operators, an armorer, and three vehicle drivers. The supply section draws and issues all classes

of supply except I, V, VIII, and IX. It can also transport and deliver these supplies to the three firing platoons. Equipment includes a cargo truck, three HMMWVs, and two HEMTT fuel tankers.

### Maintenance Section

The battery maintenance section performs organizational automotive maintenance on all battery equipment except radio and electronic equipment. The section is organized and equipped to field on-site unit maintenance teams for equipment repair. The section maintains its own prescribed load list (PLL). It can draw, transport, and issue or install all organizational repair parts for the battery. The section is equipped with a wheeled wrecker and a tracked recovery vehicle each having a secure FM radio (AN/VRC-90A), an armored maintenance vehicle with secure FM radio (AN/VRC-88A), a HMMWV with secure FM radio (AN/VRC-90A), and three cargo trucks.

### Ammunition Platoon

The platoon is comprised of a platoon headquarters and three ammo sections. The platoon headquarters includes a platoon leader, a platoon sergeant, and a driver. The three ammunition sections each have a section chief, an assistant section chief, and six ammunition specialists. The ammunition platoon provides Class V (rocket, missile, and small-arms ammunition) support to MLRS battery headquarters and the firing platoons. This includes coordination with supporting logistical headquarters for the divisional battery. The platoon has a HMMWV with secure FM radio (AN/VRC-89A) and twelve HEMTT/HEMAT truck and trailer combinations equipped with FM radios (AN/VRC-87A).

### Firing Platoon Headquarters

Each firing platoon headquarters includes a platoon leader, a platoon sergeant, a reconnaissance sergeant, a battery display operator, a radio operator, and two fire direction specialists. The headquarters conducts platoon reconnaissance, surveillance, and occupation of position (RSOP) and performs all command, control, and logistical coordination functions for the platoon. The platoon may also perform tactical fire direction when required. Each platoon headquarters is equipped with an armored command post carrier with four FM radio systems (two each AN/VRC-92A), two HMMWVs with FM radio systems (one AN/VRC-90A and one AN/VRC-92A), a FDS (AN/GYK-37), and a PLGR.

**Firing Section**

Each firing section includes a section chief, a gunner, and a launcher driver. The firing section is responsible for tactically positioning the launcher for survivability and firing operations. The section performs all technical fire control, operator maintenance, and launcher organizational maintenance. Equipment includes the M270 launcher with dual FM radio system (AN/VRC-92A), and a PLGR.

---

**Section II**  
**DUTIES OF KEY PERSONNEL**

---

**MLRS Battalion**

Although the duties of key personnel in the MLRS unit closely parallel those in other artillery units, they are unique in some ways. Generally, MLRS battalion and battery personnel are responsible for tasks performed by higher grades in cannon units. The discussions in this chapter cover the major duties of personnel in MLRS units. They are not intended to be all-inclusive but rather to highlight major functions unique to the system.

**Battalion Commander.** The battalion commander, aided by the battery commanders and staff, controls all the tactical, training, logistical, and administrative activities of the battalion. He directs employment of the battalion in accordance with assigned missions and the guidance from force FA headquarters. He works closely with the commanders of supported and supporting units to ensure that the battalion can accomplish its mission. He establishes policies to promote discipline and morale within the battalion.

**Executive Officer.** The XO directs, supervises, and ensures coordination of the staff sections. He oversees all logistical functions within the battalion, acts on behalf of the commander to direct the logistical support of the battalion, and commands the battalion in the absence of the commander.

**S3 Officer.** The S3 is responsible for operations, planning, and training within the battalion. Through the operations and fire direction sections, he provides tactical and fire direction control to the batteries. He directs the employment of the batteries to meet the needs of the supported units. He plans for the employment of the batteries and recommends the allocation of resources based on the current tactical situation and proposed future actions. He prepares and

publishes command standing operating procedures (SOPs), operation plans (OPLANs), and operation orders (OPORDs). He is responsible for establishing and directing the battalion training plan.

**S1 Officer.** The S1 coordinates and directs the activities of the battalion PAC to ensure that the commander's policies, guidance, and orders for personnel administration are implemented. The S1 is the main staff advisor to the commander in the areas of personnel management, morale, discipline, and equal opportunity. He maintains the unit strength through requisition of new personnel and out processing of departing soldiers.

**S2 Officer.** The S2 supervises the intelligence section. He develops the priority intelligence requirements (PIR) related to fire support. He coordinates with the S3 for survey support for attached TA assets. He manages all attached field artillery target acquisition systems as well as army, joint, and national sensor system down-links under the battalion's operational control. He processes and correlates targeting data to include predicting artillery target locations and passes this information to the controlling FA headquarters and the battalion FDC. He monitors enemy artillery tactics and techniques. He coordinates the battalion ground and air defense plans with the batteries. He also nominates zone coverage, and cueing schedule for all attached or GS radars.

**S4 Officer.** The battalion S4 coordinates all logistical functions for the battalion. He is responsible for the continuous flow of all classes of supply (except Class VIII and IX) to the battalion. He identifies the support requirements, provides them to the supporting unit, and coordinates with the supporting unit to ensure requirements are met. He recommends policies and procedures to increase unit logistic readiness posture.

He provides guidance on the execution of logistics operations to the battery supply sections.

**Liaison Officer (LNO).** The LNO directs the liaison teams and represents the MLRS battalion commander with supported units. He advises the supported commander on battalion capabilities, limitations, and disposition. He recommends employment options and helps coordinate fires of the MLRS battalion with other fire support assets. He keeps the MLRS battalion commander informed on the current situation of the supported unit and on future requirements.

**Fire Direction Officer.** The battalion fire direction officer (FDO) is primarily responsible for supervising all tactical fire direction in the battalion. On the basis of guidance from the commander and S3, he decides where and how the battalion and any reinforcing units will fire. He is responsible for securing and supervising input of appropriate parameters into the FDS database. The FDO analyzes requested targets for attack by field artillery taking into account the desired effects, method of fire, and types of ammunition needed. He ensures complete dissemination of fire plans to subordinate elements. He conducts rehearsals of fire plans with subordinate and reinforcing firing units as well as attached acquisition assets and sensor system down links. He is responsible for establishing and maintaining data communications within the battalion, its attachments, and the controlling FA headquarters.

**Battalion Operations Officer.** The operations officer works directly for the S3 and is a tactical operations center (TOC) duty officer. He assists in developing OPORDs and OPLANs and maintains the tactical situation maps and overlays and plans and coordinates tactical movements and positioning. The operations officer develops the execution matrix which includes projected operation areas, a by-phase/event scheme of support and current fire support coordinating measures in effect.

**Battalion Maintenance Officer.** The BMO advises the commander and coordinates external maintenance support. He provides advice and expertise to the battalion and battery commanders. He recommends maintenance procedures and policies to facilitate support. He coordinates for maintenance and repair parts support from DS maintenance units and oversees the battalion maintenance section. The BMO monitors maintenance activities of the battalion. He is

the primary advisor to the commander on all maintenance related activities.

**Battalion Signal Officer (BSO).** The BSO is the MLRS battalion commander's principal advisor on communications and signal operations. He has staff responsibility for establishing and maintaining all types of communication in the battalion. He integrates the battalion communications system into those of the supported force and force FA headquarters.

**Chemical Officer.** The chemical officer advises the commander and staff on NBC defense matters. He prepares the NBC portion of plans and orders and prepares NBC estimates and SOPs for defense against NBC attacks. He exercises staff supervision over NBC training throughout the battalion.

**Chaplain.** The battalion chaplain advises commanders on moral and ethical matters. He coordinates and conducts garrison and field services and soldier welfare ministries. He provides counseling as required for all soldiers and helps maintain the morale and spiritual well-being of all personnel.

**Physician Assistant (PA).** The PA advises the commander on all health-related issues. He is responsible for immediate medical services for field casualties within the battalion and coordinates all medical support with higher headquarters in coordination with the S3 and S1. He supervises the operations of the battalion medical treatment team.

**HHS Commander.** The HHS commander is responsible for maintaining personnel and equipment readiness within HHS battery. He ensures provision of supply, maintenance, food service, and administrative support for HHS elements. He must work closely with the staff officers, as most of the soldiers assigned to the battery work within the staff. He may conduct RSOPs for the battalion HQ and act as the battalion command post (CP) area commander.

**Battalion Maintenance Technician.** The battalion maintenance technician provides technical advice and expertise to the battalion and battery commanders. He coordinates for maintenance and repair parts support from DS maintenance units and supervises the battalion maintenance section in the absence of the BMO.

**Property Book Officer.** The property book officer (BMO) coordinates all supply activities in the battalion.

## FM 6-60

He is responsible for maintaining property accountability and the battalion property book. He helps the battery supply sergeant's request and receives supplies by coordinating with supporting supply activities. He works closely with the Operations section in monitoring the resupply of ammunition and fuel. He supervises the battalion supply section in the absence of the S4.

**Command Sergeant Major.** The CSM is the senior NCO in the battalion. He executes established policies and enforces standards pertaining to performance, care, conduct, appearance, personnel management, and training of enlisted soldiers. The CSM provides advice and makes recommendations to the commander and staff on all matters pertaining to enlisted soldiers and their families. He assists in inspection of command activities, facilities, and personnel as prescribed by the commander.

**HHS First Sergeant (1SG).** The HHS 1SG is the senior NCO in the battery. He provides leadership and guidance to the battery's enlisted personnel. He is the primary administrative and logistics coordinator for the battery. He is responsible for all internal and external administrative and logistical duties.

### MLRS Firing Battery

**Battery Commander.** The firing battery commander is responsible for executing the tactical mission given the battery by the force FA headquarters. He is responsible for maintaining discipline and morale within the battery. He ensures supply, maintenance, food service, and administrative support is provided for the unit.

**Battery Operations Officer.** The operations officer is, in effect, the S3 of the firing battery. He supervises the BOC, which is the command and control (C2) center of the battery. He keeps tactical situation maps and overlays: plans and coordinates tactical movement and positioning, with the commander's guidance; and processes intelligence information. He directs logistical efforts in coordination with the 1SG and ammo platoon leader or, if in use, with the battery logistics operations center (LOC). As the point of contact between the controlling artillery or maneuver headquarters and all battery elements, he informs the commander of all directives from higher headquarters, passes reports to higher headquarters when appropriate, and establishes

and maintains communications with higher headquarters and all battery elements. He supervises the C2 of battery elements, according to the commander's guidance, and orchestrates the commander's guidance during all movements of the battery elements. He also supervises comm procedures and net discipline. His primary concern is with the tactical control of the battery.

The operations officer is also responsible for the operation of the FDC. Although he is not an FDO, he supervises the FDC chief computer's actions and is responsible for ensuring the timely transmittal of fire missions and other data to the batteries. He is concerned with selection of firing platoons to fire, fire support coordinating measures, status of the firing platoons, and ensuring the controlling FA headquarters has the most current platoon tactical information.

**Ammunition Platoon Leader.** The ammo platoon leader is usually the firing battery logistics officer with responsibility for coordinating all ammo resupply for the battery as well as all maintenance efforts. His responsibilities include ammo resupply operations for the supporting ammunition transfer point (ATP) or ammunition supply point (ASP), positioning the ammo platoon elements within the battery ammunition holding area (AHA), and establishing communications. Normally, he performs the duties of battery motor officer. As such, he coordinates with the bn/div arty administrative and logistical operations center (ALOC) and/or the BOC for maintenance support and directs all maintenance efforts. Through the BOC, he keeps the commander informed of the maintenance situation. The Ammo Platoon leader must coordinate with the BOC/bn/div arty ALOC to plan for centralized ammo resupply of the firing platoons and convoys to the ATP or ASP. If the distance to resupply points is great, he may have to arrange for refueling, rations, approval of the route, and intelligence information for the convoy. He coordinates with the BOC to keep the commander informed of the battery ammo status and the status of the ammo platoon elements. If ammo resupply has been decentralized, the firing platoon leader will coordinate with the BOC and supervise resupply operations within his platoon. The ALOC will still be used to coordinate with the bn/div arty ALOC.

In divisional MLRS batteries, the duties of the ammunition platoon leader are larger in scope. He works closely with the div arty XO, S-4, and the division main support battalion (MSB) in the coordination of logistical support for the battery.



**Firing Platoon Leader.** The firing platoon leader is responsible for the tactical control of the firing platoon. He reconnoiters and selects platoon operational areas (OPAREAs) on the basis of guidance from the BOC and battery commander. He selects the location of the platoon HQ, OPAREA rendezvous point, reload points (RL), AHAs, and initial firing areas. These positions should enhance platoon survivability and communications between the platoon HQ and the deployed launchers.

The firing platoon leader selects the location of the platoon survey control points (SCPs). If the SCPs are not established by PADS, he establishes survey control by the use of alternate methods of survey (see Chapter 4).

The platoon leader should carry his own survey stakes and tags, whether or not he uses an alternate method of survey, to mark his positions if he arrives before PADS. This will enable him to mark specific points and continue to perform his reconnaissance. When PADS arrives, the platoon leader can brief the location of the stakes so the survey NCO can mark the points with more precise survey.

The firing platoon leader designates platoon launchers for firing selected munitions. He also designates the operational status of the launchers and determines their employment sequence on the basis of guidance from the commander, the BOC, and mission requirements. He then sends this information to the BOC, and the BOC selects the launchers to fire.

He establishes communication with the BOC and ensures that the BOC is informed of the status of the platoon. He supervises and assigns missions to the platoon recon sergeant.

The firing platoon leader and platoon sergeant coordinate the maintenance effort within the platoon. They ensure operator unit-level FCS and LLM maintenance is performed. They control any DS level FCS and LLM mechanic maintenance support teams (MSTs) assigned to the platoon. They may request additional maintenance support when needed.

**First Sergeant.** The firing battery 1SG is the senior NCO in the battery. He provides leadership and guidance to the battery's enlisted personnel. He is the primary administrative and logistics coordinator for the battery. He is responsible for all internal and external

administrative and logistical duties, with the exception of rocket/missile ammunition and maintenance. His principal duties in this area include the following:

- Coordinating with the controlling headquarters to determine the location and status of support activities. These activities include the supporting maintenance activity; nearest water and ration distribution point; nearest petroleum oils and lubricants (POL) distribution point; supporting shower and laundry points; and supporting Class II and Class VII activities.
- Guiding and supervising internal battery support activities, such as battery supply, maintenance, and food service operations.
- Directly supervising the battery clerk (divisional battery) and combat medic.
- Coordinating with the BOC and LOC for overall battery administrative and logistics support of the firing platoons.
- Ensuring the above support is timely, adequate, and consolidated as much as possible.
- Developing and supervising the battery defense.

**Ammunition Platoon Sergeant.** The ammo platoon sergeant is the primary assistant to the ammo platoon leader. He selects and reconnoiters routes to and from the ATP and ASP, directs and commands convoy movements of ammo vehicles, and coordinates with the division ammo officer for all Class V resupply. If the battery is assigned to a battalion, the S4 may coordinate with the division ammunition officer (DAO). If a LOC is being used, he helps the ammo platoon leader supervise it. He keeps the ammunition document register and accountability files.

**Firing Platoon Sergeant.** The firing platoon sergeant supervises the platoon HQ, including operations with the platoon FDS. He ensures that all reports submitted to the BOC are accurate and timely; and, in the platoon OPAREA, he controls the ammo vehicles and monitors ammo resupply. He must be prepared to reconnoiter firing points, reload points, and AHAs. He maintains the status of launcher sections; plans and coordinates the defense of the platoon elements; and assists the platoon leader in command, control, and execution of the platoon mission.

## FM 6-60

**Fire Direction Computer.** The fire direction computer is the primary assistant to the operations officer. He directly supervises the FDC and FDC operations. He organizes the BOC for 24-hour operation, directs its setup, and controls the battery radio nets. In coordination with the operations officer, he monitors all radio transmissions and ensures that all pertinent information and fire missions are quickly relayed to the proper agencies. He maintains the fire direction capabilities map, supervises upkeep of FDC operations records and reports, and keeps the operations officer informed.

**Firing Section Chief.** The firing section chief is responsible for all activities involving the launcher. This includes selecting the hide area and refining firing point in accordance with guidance given by the platoon leader/sergeant. He ensures the launcher is properly emplaced and prepared for action. He measures and reports immediate mask to the firing platoon HQ. He observes and checks the functioning of equipment during firing, movement, and reload operations. He immediately reports errors, unusual incidents, or equipment malfunctions to platoon HQ.

**Battery Motor Sergeant.** The battery motor sergeant supervises the battery maintenance section and

provides technical guidance to the soldiers in the accomplishment of their duties.

**Supply Sergeant.** The battery supply sergeant directs supply personnel in establishing supply and inventory control management functions. He maintains property under standard property book system (SPBS); reviews daily and monthly records of issues of petroleum products and operating supplies; provides technical assistance to equipment records and parts specialist; and assists and advises supply officer and commander.

**Senior Food Operations Sergeant.** The battery senior food operations sergeant supervises shift, unit, or consolidated food service operations in field or garrison environments. He establishes operating and work procedures, inspects food preparation/storage areas, and dining facility personnel. He determines subsistence requirements, and requests, receives, and accounts for subsistence items.

**NBC NCO.** The NBC NCO provides training, advice, and supervision regarding the proper use and maintenance procedures for chemical equipment and chemical operations.

**CHAPTER 3**

**EMPLOYMENT**

*This Chapter Implements QSTAG 217 and STANAG 2934, Chapter 3.*

**MLRS units are employed to provide FA medium range rocket and long range missile fires in support of the corps, Army, theater, joint or coalition forces and Marine MAGTFs or in the conduct of TMD to destroy, neutralize or suppress the enemy in accordance with Army depth and simultaneous attack doctrine. Successful MLRS operations start with a sound organization for combat that maximizes MLRS capabilities. Key to this process is a complete understanding of employment considerations and a thorough analysis of the factors of METT-T (mission, enemy, terrain, troops, and time available).**

*This section implements QSTAG 217 and STANAG 2934, Chapter 3.*

**Section I  
OPERATIONS IN WAR**

**General Employment  
Considerations**

The corps, division, and joint task force (JTF) commander's areas of operation normally include all areas occupied by enemy forces that may jeopardize completion of the current mission. Often, MLRS can engage enemy forces to the full depth of those areas of operations. Fire support planners must consider many factors when employing MLRS.

**System Capabilities**

The tremendous flexibility of the MLRS makes it an important fire support asset to maneuver commanders at all levels. The MLRS C3 capabilities; the organizational structure; and the system range, firepower, and munitions, all contribute to this flexibility (see Table 3-1).

The MLRS C3 system can interface with many types of other C3 systems. This allows for an interface with numerous C2 computer systems as well as target acquisition (TA) and sensor systems (see Chapter 5).

The MLRS organizational structure allows assignment of tactical missions down to the firing battery and platoon levels, if required. The MLRS firing batteries are equipped to operate independently from parent battalion control. The MLRS firing platoons may execute separate standard or nonstandard tactical missions for limited

periods. Augmentation of platoon assets increases this semi-independent capability.

**Table 3-1. Range Comparison**

SYSTEM	MIN RG	MAX RG
MLRS M26 Rocket (DPICM)	10 km <sup>1</sup>	32 km
MLRS M39 Missile (APAM)	25 km	165 km
<b>Note:</b> <sup>1</sup> Submunition dud rates increase at ranges less than 10 km. The system software will allow firing at ranges down to 5 km.		

The MLRS range, firepower, and munitions give fire support planners flexibility in supporting the maneuver plan. Every U.S. Army M270 launcher has the capability of firing the entire MFOM. However, the launcher FCS must be configured to fire the desired munition types.

**Mission and Enemy**

The commander's scheme of maneuver and the enemy's capabilities and predicted courses of action identified by the intelligence preparation of the battlefield (IPB) are the next considerations in employing MLRS.

**Close Operations.** In the close fight, MLRS best supports the maneuver commander with rocket fires.

MLRS rocket range exceeds most cannon munitions and allows maneuver commanders the opportunity to augment cannon fire with a lethal indirect fire capability enhancing maneuver force protection. In close operations, MLRS can be used for counterfire, raids, suppression of enemy air defense (SEAD), and engaging targets beyond the FLOT that will impact upon the close battle. The targets best suited for MLRS in the close fight are personnel, light materiel, CPs, and self-propelled artillery. The MLRS M26 rocket has a large “footprint” (dispersion of submunitions in the target area) and therefore requires detailed planning in close operations. Planners should ensure that the MLRS footprint and probability of dud munitions in the target area are considered by maneuver commanders when synchronizing battle plans. The same planning factors for 155-mm or Air Force-delivered DPICM will provide acceptable data for planning in close operations. Specifically, they must be careful not to assign missions or targets that are closer than 2000 m to friendly troops. Some risk will be accepted when firing MLRS into areas friendly units could occupy or pass through during future operations.

**Deep Operations.** Army doctrine (FM 100-5) requires the field artillery to provide deep fires and fires in support of other deep operations. The MLRS can support the commander’s deep operations plans with M39 (Army TACMS) missile fires normally fired by corps GS MLRS units. With a range of 165 km, the M39 is well suited for attack of long-range, high payoff targets (HPTs). This includes attack of HPTs with extremely short dwell times where minimizing the time from acquisition to firing (sensor-to-shooter time) is critical. Chapter 4 discusses options for posturing units and Chapter 5 discusses methods to reduce processing times in these situations. The range capability also allows engagement across the front laterally. The methodology for planning and executing deep operations is decide-detect-deliver-assess (D3A). This methodology requires that targets and their areas of engagement be planned during the decide phase. In deep operations, most fires are planned and scheduled as opposed to immediate, unscheduled fires on targets of opportunity. In the planning process of the decide phase, the following must be considered:

- The M39 missile stockage levels and locations. Management and delivery of munitions depend heavily on fire planning decisions made early in the decide phase.
- Target acquisition (TA) and sensor system availability, C3 linkage to the MLRS firing unit, and target acquisition and sensor systems cuing to detect and/or track targets.

These assets (launchers, munitions, and TA and sensor systems) are limited. Therefore, fire support planners must carefully plan and coordinate the development of deep targets and their attack. The warhead description and capabilities of the M39 missile are addressed in Chapter 1. The D3A methodology and the doctrine for planning and executing fire support in deep operations are addressed in FM 6-20-30 and FM 6-20-10.

**Rear Operations.** The objective of rear operations is to ensure freedom of action and continuity of operations, logistics, and battle command. Use of MLRS fires in support of rear operations is limited because MLRS is an area fire weapon; it is not the FS weapon of choice for rear operations. MLRS fires may, however, be required in support of division or corps response operations and/or tactical combat force (TCF) operations.

### **Positioning**

Proper positioning and employment of MLRS units increase their effectiveness. The MLRS units fight forward, positioned as close to the FLOT as possible, to maximize the system’s ability to attack deep. Positioning launchers forward and intermixing them with other fire support systems and maneuver units in the maneuver brigade sector degrades the ability of the enemy to template MLRS operations and locations. Shoot-and-scoot tactics are used to reduce the enemy’s ability to acquire and engage MLRS launchers with indirect fires. Fighting forward, however, does increase the risk to soldiers since MLRS units have a limited ability to defend themselves against ground attack. When positioning forward, minimum range is also a consideration. It also increases coordination requirements because the signature of MLRS when it fires increases the vulnerability of all elements in the immediate vicinity to enemy fires. Digital communications are essential for effective MLRS operations. Communication requirements, particularly FM line of sight, area key consideration when selecting position areas.

### **Planning and Coordination**

Employment of the MLRS requires thorough planning and coordination. Operations orders and fire support plans should include detailed tasks and instructions for MLRS units. These instructions must include types and amounts of each munition by unit, platoon and/or launcher posturing (see Chapter 4), and FCS configuration for specific launchers. Planning should consider the need for launcher redundancy in the allocation of targets to ensure timely target attack. (See Appendix B, *Field Artillery Support Plan*.)

**Rocket fires** will generally be short of the division and/or corps fire support coordination line (FSCL). There should be emphasis during planning and coordination on establishing procedural controls and deconflicting these fires with the division Army airspace command and control (A2C2) element.

**Missile fires** will generally be beyond the FSCL because of the range of the weapon and expected target types. There should be emphasis during planning and coordination on establishing procedural controls and deconflicting these fires with the joint force, particularly, the air component. While there is no requirement to coordinate or seek approval prior to the delivery of fires beyond the FSCL (but within the area of operations [AO]) of the force headquarters, there is a responsibility to notify the affected components to reduce the risk of fratricide, increase efficiency, and avoid duplication when possible. Accurate reporting of platoon center locations is paramount since these locations are used to develop and coordinate air force restricted operations zones (ROZs).

Maneuver and force FA commanders must consider the items discussed below when planning for MLRS fire support.

**Fire Missions.** The MLRS, in support of close operations, uses two basic types of fire missions--planned (scheduled) and targets of opportunity (unscheduled). MLRS fires typically require longer reaction times than cannon systems. The MLRS is suited more for planned missions. Both scheduled and unscheduled missions are used in the offensive and defensive phases of the close battle. (For further discussion of fire planning, see Chapter 5.)

**Configuration Time.** Normally, all the weapon files required to carry out anticipated missions are loaded in the launcher FCS before fire missions begin. Changing from one munition to another takes no additional time if the correct weapon files are loaded. Unusual circumstances may warrant loading additional files.

**Reaction Time.** The MLRS units normally require at least 30 minutes to process and execute any fire plan. This time can be reduced by using methods other than the non-nuclear fire plan (NNFP) function of FDS (see Chapter 5 for more information).

**Launcher Response Time.** The MLRS response time on any given mission may vary from 2 to 20 minutes (see Chapter 4 for more information).

**Munition Load.** The MLRS units may carry any of the MFOM. The unit mission dictates a munition load and

resupply necessities. Mission changes may require exchange of part or all of a unit's ammo stocks.

**Munition Range.** The minimum and maximum munition ranges must be considered in positioning elements and assigning missions.

**Note:** More detailed discussions of MLRS battalion, battery, and platoon operations are in Chapters 5, 6, and 7.

### Survivability

**Movement.** The shoot-and-scoot tactics combined with the wide dispersion of elements help MLRS elements avoid detection and minimize vulnerability. Survivability is enhanced by the rapid transmission rate of digital message traffic, secure voice communications, quick emplacement and displacement. However, they also require more planning and coordination because of competition for terrain. Firing platoon leaders and battery commanders must coordinate with maneuver unit commanders throughout all phases of an operation.

**Mission.** The M270 firing missiles may be less vulnerable to counterfire than it is when firing rockets. This is due to a shorter time from initial launch to movement from the firing point and randomly selected off-axis firings. The M270 firing missiles will be a higher priority enemy target.

**Detection.** The key to MLRS survival on the battlefield is the avoidance of detection. Enemy forces can detect MLRS units firing either rockets or missiles by the means discussed below.

- **Air-Ground Observation.** Until it fires, an M270 launcher normally is difficult to detect by air-ground observation. During firing, the large signature of the launch provides easy location of the firing point by direct observation.
- **Counterbattery Radar.** At lower firing elevations (less than 300 mils), MLRS rockets are difficult to detect by counterbattery radar. At firing elevations greater than 300 mils, the rockets can be more easily acquired because of their higher trajectory. The Army TACMS off-axis launch, low radar cross section, and semiballistic guided flight program further reduce MLRS vulnerability to enemy radar acquisition.
- **Sound Ranging.** The vulnerability of MLRS to detection by sound ranging exceeds that of cannon

## FM 6-60

artillery. Enemy sound ranging techniques are highly advanced and extremely accurate.

- **Flash Ranging.** The MLRS is readily detected by flash ranging because of the large visual signature of the launcher firing. Enemy flash ranging techniques are highly advanced and extremely accurate.
- **Radio Direction Finding.** Overuse of radio communications can make detection by enemy radio direction finding more likely. This is especially true because of the radio-intensive nature of MLRS operations. Terrain masking, short transmissions, and use of low radio power and directional antennas and consistent use of frequency-hopping capabilities can improve survivability.

### Organization for Combat

The force commander establishes the command and control of MLRS units through his organization for combat. This is a two-step process as follows:

- Step 1-Establish a **command relationship** by placing the unit in a specific tactical organization.
- Step 2-Assign a **tactical mission**. Divisional MLRS batteries and corps MLRS battalions will always be assigned tactical missions. The MLRS batteries of an MLRS battalion may also be assigned tactical missions.

### Command Relationships

The force commander normally establishes one of the following relationships with a tactical unit for each field artillery unit:

- Organic
- Assigned
- Attached
- Operational Control (OPCON)

A Commander-in-Chief (CINC) has other relationships available when the MLRS unit is involved in Joint operations (see Joint Pub 3.0).

- Tactical Control (TACON)

- OPCON
- Support

Normally, the force commander will select one of the following options in establishing the command relationship.

**Option 1.** The corps commander retains direct control of the MLRS battalion through the corps artillery headquarters TOC. Normally, this option is used only in controlling MLRS units configured for delivering Army TACMS fires. The corps artillery TOC does the following:

- Coordinates movement, positioning, and delivery of fires of the MLRS unit(s) to support the corps operations.
- Monitors ammunition status.
- Coordinates combat support (CS) and combat service support (CSS) for the MLRS unit(s).

The **advantages** of Option 1 areas follows:

- The corps commander can directly influence the battle as an active participant rather than as an allocator of combat power. He applies long-range missile fires at decisive points to help shape the close fight and to support his deep maneuver.
- In some situations, intelligence-generated targets may be sent directly from the sensor platform to the commander's tactical terminal (CTT) or ground station modules (GSM) at the MLRS battalion for immediate attack. Targets also can be sent by the corps to the MLRS battalion.

The **disadvantages** of Option 1 areas follows:

- Communications may be constrained by the distances over which the MLRS battalion and corps artillery TOC have to communicate.
- Terrain management for launchers is time-consuming. The coordination for OPAREAs and firing points requires clearance through the corps FSE, division FSE, brigade FSEs and, in some cases, battalion FSEs.
- Requests for additional fires from within the corps must be routed through the div arty and corps and then sent to the battalion for execution.

**Option 2.** The corps commander attaches the MLRS battalion to a FA brigade. If the corps commander keeps the FA brigade under his control with a GS or GSR mission, the corps FSE will send request for fire through the FA brigade HQ to the MLRS battalion. The battalion may continue to receive target data directly from sensors through the CTT and GSM. If the corps commander allocates or prioritizes the brigade fires to a division (reinforcing a div arty), the division FSE will send requests for fire through the div arty and then through the FA brigade HQ to the MLRS battalion.

The **advantages** of Option 2 are as follows:

- Communications relayed through the FA brigade HQ facilitate C2 of MLRS unit and launcher operations.
- The MLRS can still effectively respond to targets requested by corps.
- The corps commander can still establish priorities of fires. This will increase the combat power within a subordinate unit area.
- The FA brigade is more capable of assisting and supporting the attached MLRS battalion than a corps artillery TOC or div arty.

The **disadvantages** of Option 2 are as follows;

- When brigade fires are not allocated to a division, the processing time for division requests for fire is increased. (A quick fire link might be established from div arty to the FA brigade to preclude this problem.)
- Coordination with maneuver units for position areas may be difficult and time-consuming.

**Option 3.** The corps commander allocates some or all of the MLRS units directly to the divisions, thus increasing their combat power. This decentralized employment of the MLRS battalion may be most appropriate to fast-paced offensive operations. The MLRS battalion, or its batteries, may be attached to a committed division. This division normally would further attach the MLRS unit to the div arty. The div arty must provide information on the following:

- Required supply rates for ammunition.
- Target attack criteria.
- The SEAD criteria.

- Interdiction requirements.
- Supportability of future operations.

If the corps commander attaches an MLRS battalion to a division, the battalion, operating with the div arty, may assume OPCON of the divisional MLRS battery. Priority of fires, with specific target criteria, can be established and shifted quickly within the division in accordance with the plan for support.

The **advantages** of Option 3 are as follows:

- Additional MLRS units give the division more immediately available combat power.
- Communications are streamlined between the MLRS unit and its supported headquarters.

The **disadvantages** of Option 3 are as follows:

- It may be time-consuming to change the task organization and get the pure battalion back under the corps artillery of FA brigade control when required.
- Fire planning and MLRS attack of targets identified at corps and echelons above corps are degraded because there are no immediately available MLRS fires at that level.
- If all MLRS assets attached to the divisions, no MLRS units could be assigned the mission of GS to the corps for Army TACMS fires.

### Tactical Mission Assignment

Field artillery battalions normally meet their FA support requirements through one of the four basic or standard tactical missions. Assignment of a tactical mission implies that a FA commander will meet each of the seven inherent responsibilities of his mission, as applicable (see Table 3-2, page 3-6).

**Considerations.** The corps MLRS battalion and the divisional battery may be assigned any tactical mission consistent with the force commander's fire support guidance. The MLRS units can readily accomplish R, GSR, and GS missions. Because the divisional MLRS battery does not have a liaison section, it must fulfill liaison requirements with internal assets. The battery commander may choose to collocate his CP with that of the supported unit.

**Table 3-2. Seven Inherent Responsibilities of Artillery Standard Tactical Missions**

AN FA UNIT WITH A MISSION OF--	DIRECT SUPPORT	REINFORCING	GENERAL SUPPORT REINFORCING	GENERAL SUPPORT
1. Answers calls for fire in priority from--	1. Supported unit. 2. Own observers. <sup>1</sup> 3. Force FA HQ.	1. Reinforced FA. 2. Own observers. <sup>1</sup> 3. Force FA HQ.	1. Force FA HQ. 2. Reinforced unit. 3. Own observers. <sup>1</sup>	1. Force FA HQ. 2. Own observers. <sup>1</sup>
2. Has as its zone of fire-	Zone of action of supported unit.	Zone of fire of reinforced FA.	Zone of action of supported unit to include zone of fire of reinforced FA uni	Zone of action of supported unit.
3. Furnishes FIST or FSE <sup>2</sup> --	Provides temporary replacements for casualty losses as required.	No requirement.	No requirement.	No requirement.
4. Furnishes liaison officer--	No requirement.	To reinforced FA unit HQ. <sup>3</sup>	To reinforced FA unit HQ.	No requirement.
5. Establishes communication with--	Company fire support officers (FSOs) and supported maneuver unit HQ.	Reinforced FA unit HQ.	Reinforced FA unit HQ.	No requirement.
6. Is positioned by--	DS FA unit commander or as ordered by force FA HQ.	Reinforced FA unit or as ordered by force FA HQ.	Force FA HQ or reinforced FA unit if approved by force FA HQ.	Force FA HQ.
7. Has its fires planned by--	Develops own fire plans.	Reinforced FA unit HQ.	Force FA HQ.	Force FA HQ.
<p><b>Notes:</b> <sup>1</sup> Includes all TA means not deployed with a supported unit (radar, aerial observers, survey parties, etc.)  <sup>2</sup>A fire support element (FSE) for each maneuver brigade, battalion, or cavalry squadron and one fire support team (FIST) with each company or ground cavalry troop are trained and deployed by the FA unit authorized these assets by TOE. After deployment, FISTs and FSEs stay with the supported maneuver unit throughout the conflict.  <sup>3</sup> If the reinforcing mission is to a DS battalion, there may be a need to establish additional liaison of the force FSE.</p>				

**General Support.** An MLRS unit assigned a GS mission provides FA support for the force as a whole. This is the most centralized mission for the force commander. It provides fires that are immediately responsive to his needs. Planned fires and fires against HPTs are best provided by those MLRS units with a GS mission. Assigning a GS MLRS unit a priority of fires allows the commander to influence specific areas of the battlefield. The priority of fires option can fulfill many of the R and GSR needs.

**General Support Reinforcing.** The GSR mission requires the MLRS unit to furnish fires for the force as a whole as its first priority and to reinforce the fires of

another FA unit as the second priority. A GSR unit remains under the tactical control of the force FA headquarters and responds on a first-priority basis to the needs of that headquarters. The GSR mission gives the force commander flexibility to meet the needs of various tactical situations.

**Reinforcing.** If assigned an R mission, the MLRS unit should operate on the reinforced artillery battalion Ops/F (VHF-FM) (digital) and cmd (VHF-FM) (voice) nets. Communication with the force FA headquarters should be maintained with the HF AM radio and/or mobile subscriber equipment (MSE). The MLRS battalion has a liaison section to help in implementing and executing an



R mission. There is no organic liaison capability at the firing battery. The BC can do this to some extent. A major consideration in giving an MLRS unit an R mission is the ammo expenditure rate. In an R role, expenditure of MLRS ammo may exceed the unit resupply capability. Another consideration is ensuring the reinforced unit understands MLRS capabilities and limitations. When reinforcing a DS cannon battalion, liaison at both the FA unit HQ and the force FSE may be appropriate.

**Direct support.** Normally, establishing appropriate priorities of fire modifying the GS, R, or GSR missions will be adequate to handle those instances where MLRS must be extremely responsive in support of a maneuver force. When possible, MLRS units should reinforce the habitually associated DS cannon unit rather than assuming the DS mission on its own. However, an MLRS unit may have to assume a nonstandard DS mission, because it is the only indirect fire asset available. Before assigning a DS mission to any MLRS unit, the following factors should be carefully considered:

- The MLRS battalion lacks the fire support coordination personnel normally associated with a DS FA battalion. The organic liaison section is inadequate to satisfy this function.
- Given its large footprint and greater range, MLRS DPICM is best used against area targets and to complement cannon fires.
- Danger close for MLRS M26 rockets is 2 km.
- MLRS tires are normally less responsive than cannon fires.
- The MLRS has extensive ammo resupply considerations that adversely impact on its ability to sustain continuous fires.
- The MLRS lacks the munitions normally required for a DS mission (for example, illumination and smoke).
- The MLRS comm nets are insufficient for the DS mission.
- The use of MLRS in the decentralized DS mode denies the force FA commander the use of an important asset needed to influence the battle.
- Precision Error. Rockets are inherently less precise than cannon projectiles. They have a much larger CEP are therefore much less predictable. Inherent

random inaccuracies (bias and precision errors) are discussed in Appendix C.

**Nonstandard Mission.** If the commander's intent cannot be satisfied with one of the standard FA tactical missions, a nonstandard tactical mission maybe assigned. These missions amplify, limit, or change one or more of the inherent responsibilities or spell out contingencies not covered by those responsibilities. A nonstandard mission may be assigned if there is not enough artillery to cover all the contingencies or if a FA battalion, FA battery, or MLRS platoon is required to meet the responsibilities of more than one tactical mission. Examples of some nonstandard missions include those discussed below:

- An MLRS firing battery answers calls for fire from a combat aviation brigade. The FDS can communicate digitally with an aerial observer in an OH-58D through the helicopter's airborne target handover system (ATHS). It also can communicate digitally with an observer using a digital message device (DMD) or other hand-held digital device in an OH-58A or OH-58C helicopter. The battery FDC also can receive voice calls for fire from aerial observers. All of these configurations allow the MLRS firing battery to engage the variety of targets the aviation brigade can acquire.
- A battery from an MLRS battalion is attached to a FA brigade which is DS to an ACR or separate maneuver brigade but remains GS to the regiment or brigade.
- An MLRS battalion is attached to a FA brigade which is reinforcing a Marine Corps or coalition army force artillery headquarters. However, the MLRS battalion is positioned by and has its fires planned by the reinforcing FA brigade headquarters, not the force FA headquarters.
- A nondivisional MLRS battery is GSR to a DS cannon battalion but is positioned by and has its fires planned by the reinforced FA unit headquarters.

## Operations with the Marine Corps

This section discusses operational considerations when supporting MAGTF operations.

### Size of Force

The most appropriate force alignment is an MLRS battery supporting a Marine Expeditionary Force (Forward) MEF

## FM 6-60

(FWD) and an MLRS battalion supporting a Marine Expeditionary Force (MEF). The smallest MLRS unit to deploy in support of Marine Corps (USMC) operations will be a battery. However, the number of launchers in the battery may be tailored to a specific mission. Subdivision below the battery level could limit the operability, flexibility, response, and sustainability of MLRS fires. MLRS units will be selected to support USMC requirements based on METT-T considerations. Only echelon-above-division (EAD) units (AC or RC) may be selected to fulfill support needs.

Each deployment package must be supplemented with an additional logistical package (see Chapter 6, *Combat Service Support*) due to the lack of Army support available and the likelihood that the unit would be entering an immature theater. Additionally, the MLRS battery requires liaison and staff augmentation. Elements of an MLRS battalion headquarters could effectively perform the function of interfacing with a USMC controlling headquarters on operational and logistical matters.

### Deployment

The method of deployment/entry will largely depend upon METT-T considerations corresponding to the specific contingency operation. It is a function of the size of the force, time available, availability of secure airfields and port facilities, and whether or not an amphibious landing is to an uncontested or benign beach or port.

### Battle Command

The MLRS unit should be under the command and control of the force field artillery headquarters. In the case of a MEF (FWD), this would be a Marine artillery battalion. In the case of a MAGTF of larger size, this would be the Marine artillery regimental command operations center (COC). Although MLRS units best provide general support fires, the MAGTF commander will ultimately direct tactical mission assignment.

**Communications.** Army and USMC radio systems (AM and FM) are compatible. MLRS units supporting USMC units not equipped with SINCGARS will operate in a non frequency hopping mode. There are some unique challenges regarding data communications between VRC-12 series radios and SINCGARS. These are addressed in Chapter 7 (*MLRS Communications*).

**Artillery Computer Systems.** There are few compatibility issues with regard to data communications. The MCFSS and the MLRS FDS and FDDM all communicate using TACFIRE protocols. Version 10 software allows full compatibility of MCFSS and FDS/FDDM with current rocket and missile munitions.

**Communications Security (COMSEC).** Army and Marine Corps COMSEC systems are compatible using both SINCGARS and VRC-12 series radio systems. Both MCFSS and MLRS FDS/FDDM use the KY-57 for data encryption. The MLRS battery, when operating separately, requires three (3) internal communications nets and one (1) for liaison. The entire MLRS battalion requires a minimum of fourteen (14) internal communications nets in order to function. The USMC is responsible for providing these communications nets in the signal operating instructions (SOI).

**Target Acquisition.** The USMC has both unmanned aerial vehicles (UAVs) and organic TPQ-36 radar sections for use in both intelligence gathering and acquiring targets.

- **Unmanned Aerial Vehicles (UAVs).** The USMC currently has the PIONEER system. This UAV will penetrate into enemy airspace out to a range of 185 km to conduct reconnaissance missions. It has an endurance of four hours of flight time. Both the U.S. Army and the USMC will be fielding the HUNTER system. This UAV has a range of 200 km and an endurance of eight to 12 hours of flight time.
- **AN/TPQ-36 Weapons Locating Radar (WLR).** The AN/TPQ-36 is optimized to locate high-trajectory indirect fire weapons such as mortars to a range of 15 km, but it can also locate cannon and rocket artillery to a range of 24 km.
- **AN/TPQ-37 Weapons Locating Radar (WLR).** The AN/TPQ-37 is optimized to locate low trajectory indirect fire weapons, such as cannon artillery to a range of 30 km and rocket artillery to a range of 50 km. Supplementing the force FA headquarters with multiple Army TPQ-37 radar sections would significantly add to the target acquisition capability of the MAGTF.

**Liaison.** During joint operations, liaison is normally reciprocal. This would require the controlling USMC headquarters to provide a liaison to the MLRS unit headquarters as well.

## Offensive Operations

An MLRS unit must be prepared to support the four basic types of offensive operations:

- Movement to contact.
- Attack.
- Exploitation.
- Pursuit.

A detailed discussion of these operations and the responsibilities of the fire support coordinator (FSCOORD) for each of them is in FMs 6-20, 6-20-30, 6-20-40, and 6-20-50.

### Movement to Contact

Units conduct movement to contact to gain or regain contact with the enemy. Once contact is made, the commander can further develop the situation.

The MLRS can provide support during both movement and follow-on operations once contact is made. With its long range and tactical mobility, MLRS is suited to augment other artillery fires in supporting covering forces and flank guard formations.

The MLRS must be integrated into the march columns to ensure responsive supporting fires during the initial action. By planning for delivery of immediate mass MLRS fires, the commander can help the supported unit as it seizes and retains the initiative.

### Attack

The purpose of the attack is to defeat, destroy, or neutralize the enemy. Successful attacks depend on the skillful massing of effects against the enemy force. The commander's intent will drive the selection of available attack options - hasty attack, deliberate attack, spoiling attack, counterattack, raid, feint, demonstration, or any combination of these.

MLRS can best be used in support of attacks by delivering deep fires against reserve or reinforcing formations, delivering counterfire, providing SEAD, massing against counterattacks, and reinforcing the DS artillery of attacking brigades. MLRS, if employed properly, is an excellent choice in support of raids, spoiling attacks, etc. (see discussion below).

## Exploitation and Pursuit

Exploitation and pursuit operations follow successful attacks. An exploitation is when the attacker extends the destruction of the defending force by maintaining continuous pressure. A pursuit is an offensive operation against a retreating enemy force.

Both exploitations and pursuits involve rapid movement forward. The 32 km range of MLRS rockets, the 165 km range of missiles (Army TACMS), and system mobility enable MLRS to efficiently support these operations. Because of the rapid movement in these attacks, maneuver units usually are unable to coordinate extensively or directly for fire support. Without this coordination, MLRS use in these operations must adhere to positive clearance of fires procedures.

Some considerations in these types of offensive operations include: positioning MLRS units close to the line of departure or FLOT, making sure MLRS units travel well forward with maneuver units, and planning for ammunition and ammunition resupply throughout the operation.

## Defensive Operations

In defensive operations, the corps and division commanders normally have more centralized control of MLRS assets to ensure that they are immediately responsive to the force commander. However, MLRS units may be attached to or under the OPCON of armored cavalry regiments (ACRs) or other covering force units. The duration of the attachment or OPCON and other instructions and restrictions should be delineated in the OPORD.

The MLRS units can support defensive operations with fires by providing the following:

- Counterfire and SEAD fires.
- Fires on enemy C3 assets and maneuver assembly areas to disrupt command, control, and attack preparations.
- Engagement of enemy forces as far forward as possible. Attack of targets with MLRS DPICM will strip enemy forces of light armor and infantry support and will cause mobility and firepower kills to heavy armor.
- Long-range missile fires on targets arrayed in depth, deep targets, uncommitted forces, and other HPTs.

## FM 6-60

A Firefinder-MLRS direct link is most effective during defensive operations. This link allows rapid detection and destruction of enemy artillery and mortars as they fire in support of their maneuver's advance.

Defensive operations require different positioning considerations. The positioning of MLRS in the security area, to range more deeply, must be carefully considered and planned. Considerations include the following:

- Increased security risks to MLRS units.
- Communications requirements.
- Limited logistical support as a result of positioning far forward.
- Availability of suitable firing positions and routes.

In MLRS unit positioning, munition minimum range must be considered. The units could be positioned at different, staggered distances from the FLOT, which would overcome minimum range limitations.

The MLRS units should not be positioned on major avenues of approach. This is to prevent enemy breakthroughs from jeopardizing the unit or forcing it to displace prematurely. It would also preclude displacing several MLRS platoons or batteries at the same time and losing that fire support.

### Nonstandard Employment Techniques

Force commanders can employ MLRS units in numerous ways for special missions. These missions include conducting pro-active counterfire strikes against enemy indirect fire systems, attacking deep targets as part of a spoiling attack (raid), and moving forward with maneuver security forces in order to conduct SEAD missions or attack other HPTs. There are some unique considerations for planning and executing such operations. The considerations listed below are not all-inclusive. They are intended as a planning aid.

#### Mission

The force commander's intent for the mission must be clearly understood. Command of the attack force should fall to a single commander (artillery or otherwise). During the planning process MLRS unit commanders should ask:

- How much time is available to complete the mission and conduct the planned withdrawal?

- What are the proposed firing and C2 locations? What are the routes to those locations? What are the withdrawal routes?
- What is the acceptable level of risk in completing the mission (has the commander established criteria for aborting the mission)?
- What are the target descriptions? How many and of what type/size are the targets?
- What is the acquisition source?
- Are ground maneuver units available to assist in protecting both firing units and associated radars?
- Was the commander's intent established in the commander's criteria?
- Is the controlled supply rate (CSR) sufficient to accomplish current and follow-on missions?
- Is there a follow-on mission?

#### Force Protection

MLRS units are high priority targets for the enemy. Based on the nature of the mission, the attack location, the enemy situation, and the acceptable level of risk force protection requirements will vary.

- What is the threat?
- If a maneuver force is required, what is the size and structure of the force? How can that force best protect the MLRS unit?
- What is the risk of receiving counterfire? Is there a need to have acquisition assets and additional firing units for counter-counterfire?
- What is the current and projected air defense posture? Should the force include dedicated air defense weapon systems?

#### Coordination

Coordination is essential during any operation and particularly important for raids and other special missions.

- Is there a need for, and have we established, liaison with the supported and supporting forces (force maneuver TOC, security force HQ)?
- Have the routes been cleared with the appropriate headquarters?

- Are there adequate comm assets and nets? What frequencies?
- If the attack force must pass through the FLOT of another unit, then a passage of lines will be necessary. Have we conducted coordination for the passage of lines during the planning phase?

### Logistics

During special missions, there is a need to minimize the size of the force. This allows the unit to attack the targets and continue with the follow-on mission quickly. Units should include only minimum essential logistics support.

- How much and what type of ammunition is required?
- Should a maintenance support team accompany the force? If so, what should go?
- How much fuel is required? Will we require refueling in order to complete the mission?
- Will launchers require reloading? If so, how often and where will this be done?

### Organization

- How many C2 nodes does the mission require? Will a BOC or a platoon operations center (POC) be sufficient? Will it require augmentation from the TOC?
- Is there a need for maneuver to provide force protection? If so, what is the minimum required force? How are they controlled? Will they provide a liaison to the MLRS unit C2 element?
- Will we be linked directly to the corps or division FSE using a “quick-fire” net?
- What acquisition assets are available for counterfire (AN/TPQ-36, AN/TPQ-37)?
- Are electronic warfare (EW) assets going to be committed to the effort to mask the electronic signature (jammers)?

## Rehearsals

Rehearsals are an integral part of the planning process. A rehearsal should both practice and test the plan. If at all

possible, the rehearsal should be conducted with the force commander’s rehearsal. A combined rehearsal will improve responsiveness of fires and the synchronization of all the force commander’s resources for the battle.

Units must establish procedures for rehearsals as a part of their tactical SOPs. As a minimum, the SOPs should identify the following:

- Who will participate in the rehearsal.
- What should be rehearsed.
- What the sequence of the rehearsal will be.
- What the priority of methods for rehearsals will be.

### Participants

The rehearsal should include significant events, such as the maneuver scheme, target acquisition employment, and obstacle emplacement. The battalion S3, S2, FDO, attached radar personnel, and unit FDC's are all essential participants as well. Whenever possible, the firing batteries and platoons, down to individual launcher level, should participate. The battalion benefits from the rehearsal by obtaining information for movement, schedules of fire, munitions requirements, and a more complete understanding of the operational time involved with the scheme of maneuver.

If the force commander does not conduct a rehearsal and rehearsal time is available, the S3 and/or LNO should conduct a rehearsal. They should use the existing maneuver OPLAN, the fire support plan, the fire support execution matrix (FSEM), and the FA support plan and matrix. The FSEM is ideal for use in rehearsal, since the rehearsal is normally conducted by performing and/or reciting--

- Actions to occur.
- Possible friendly initiatives.
- Possible reactions to enemy initiatives.
- Control measures.
- Significant events that are to occur in relation to time or to phases of an operation.

The rehearsal conducted by only unit personnel is limited that the success of the rehearsal and benefits to be

## FM 6-60

derived from it depend on how well the LNO conducting the rehearsal knows the force commander's concept of the operation. The battalion operation section pays particular attention to displacements. The battalion FDC issues fire orders. Attached radars work situational cues with the cueing agents. Each firing unit conducts tactical and technical fire direction through launcher level. If alternative friendly courses of action hinge on enemy actions and if time permits, the alternatives may be rehearsed.

Note the important features of the rehearsal. It presupposes the complete plan--a plan complete enough to be executed, not a final or unchangeable plan. It is designed to show whether everyone knows his responsibilities (for example, for firing a target, moving a battery, switching frequencies, observing a named area of interest [NAI] and the cues for his action). It allows a check on whether the plan will work. Finally, the rehearsal as a whole is clearly under someone's direction (for example, the S3 or LNO).

### Methods of Rehearsal

There are many ways to conduct rehearsals. When time is limited, there will be no chance to rehearse everything. You must streamline your plan and focus your rehearsal on critical events.

Rehearsals may be conducted face-to-face, by wire, or by radio. The first two methods have the advantage of greater security; the last two test communications in the course of the rehearsal. Face-to-face rehearsals tend to be time-consuming and concentrate leaders in one place, but they are often the most secure and are usually the least ambiguous.

**Suitable or Actual Terrain.** The use of a suitable maneuver area or the actual area in which the operation is to be conducted is the best method for conducting a rehearsal because of its increased realism. Communications lines of sight, clutter on specific communications nets, trigger points and actual operational times required to move from position to position maybe visually simulated. This method requires a large area and an increased amount of preparation and planning time. Its use may depend on operational or signals security (SIGSEC) considerations.

**Model.** Models may be constructed showing buildings, compounds, or built-up areas. This type of rehearsal requires good intelligence information on the area of

operation and more time to construct the model itself. Normally, it is used for special operations.

**Map.** This type of rehearsal maybe conducted on any map with the appropriate overlays. This method may be used when time and rehearsal space are limited. Using this method limits the number of participants to those who can gather around a single map unless individual maps are used. Actions to be taken are recited by the participants.

**Sand Table.** The sand table method expands the area in which rehearsal participants may gather around a single graphical representation of the operation. Maneuver graphics may be depicted by using engineer tape, string, or spray paint or simply by carving out lines in the ground. Key terrain, topography, and objectives may be depicted by the use of rocks, items of equipment, or piles of earth. Preparing for this rehearsal method requires more time; however, it generally permits more participants and is a better visual aid.

**Wire.** Wire rehearsals generally limit the number of agencies that can rehearse. They also don't test the radio communication on which execution usually depends.

**Radio.** Radio rehearsals are usually the most comprehensive and the easiest to conduct on short notice, but they present the greatest risk of compromise and frequently confuse participants--"Is this a real fire mission or a rehearsal?"

### Tips for Successful Rehearsal

Whatever the technique, a successful rehearsal will be as close to the way you want to execute as possible. When a problem emerges during the rehearsal, fix it right there. To gain the most advantage from the rehearsal, the leader should do the following:

- Supervise and monitor the rehearsal to ensure that it maintains its focus and direction.
- Select time for the rehearsal that allows enough time to correct problems found in the plan.
- Use actual players, not stand-ins, especially in organizations with little experience in continuous operations. Crucial players, such as LNO, Ops officers, and radars, must be included.
- Involve all of the elements that will be required to perform the mission, concurrently if at all possible. This means including the firing batteries, down to launcher level, in the rehearsal. When firing batteries

are included in the rehearsal, the leader must distinguish clearly between the rehearsal and the execution of the plan.

- Stop and correct problems as they arise. Not all plans will be complete at the time of the rehearsal, but problems that are identified must be corrected in the plan before its execution.
- Have built-in checks of the plan. The S2 participates, and those responsible for execution report back. These checks anchor the rehearsal in the enemy situation, the terrain, and the details of the plan.
- Rehearse the plan as it will be executed; the sequence and the execution cues are the same.
- Cover, as a minimum the following at each rehearsal:
  - Grid locations for critical targets (as a minimum) are verified.
  - Trigger points, lines, or events are verified for each target.
  - Primary and backup communication links.
  - For each target, priority and purpose are established.
  - Method of engagement is specified for each target.
  - Attack guidance is specified for each target.
  - A movement plan specifying when and where units will move is prepared.

### Target Acquisition and Sensor System Interface

The MLRS C3 system interfaces directly with most digital comm systems. Therefore, it is easily linked to any TA or sensor systems equipped with digital communications. This linkage allows faster response for attack of detected targets. Five of the most likely sources of target information are the Firefinder radar, the OH-58D helicopter, the UAV, and the joint surveillance target attack radar system (JSTARS) or Guardrail signals-intelligence (SIGINT) systems.

### Firefinder Radar

The MLRS FDS at all levels can interface directly with the Firefinder DMD emulator in a digital, nonsecure mode. This link gives the force FA commander an extremely fast, responsive, and effective counterfire capability. Through zone management and the use of common sensor boundaries, MLRS-Firefinder operations can orient on the maneuver commander's battlefield priorities while still providing counterfires to the force as a whole. Specific commander's guidance is essential for providing targeting zone and report criteria for the radar section and engagement and effects criteria for the MLRS unit. (See FM6-121 for more detailed information.)

**Messages.** The Firefinder DMD emulator can transmit six and receive nine message types. The MLRS FDS can receive only the fire mission; calls for fire (FM; CFF), forward observer command (FM;FOCMD), and plain text message (SYS;PTM) messages.

**Zones.** Up to nine zones can be entered in the Firefinder radars. All zones may be one of four types discussed below or any combination of the four types. These zones prioritize target detections and determine in which format the detection will be reported.

- **A critical friendly zone (CFZ)** is an area, usually a friendly unit or location, that the maneuver commander designates as critical. It is used to protect an asset whose loss would jeopardize the mission. When the computer predicts that an enemy round will impact in a CFZ, the location of the weapon that fired the round will be reported by the computer in precedence ahead of all other detections. Any location of a weapon firing into a CFZ will result in an immediate call for fire (FM;CFF message) unless it is manually overridden by the radar operator. The FM;CFF message is received by IFSAS as a Priority I message. Thus, a CFZ provides for the most responsive submission of targets to the fire support system.
- **A call-for-fire zone (CFFZ)** designates a search area forward of the FLOT that the maneuver commander wants suppressed, neutralized, or destroyed. An area designated as a CFFZ would likely be on a suspected enemy indirect fire systems. Its designation would be closely tied to information developed during the IPB process. A CFFZ provides the second most responsive priority of requests for fire generated by the radar. A target identified in a CFFZ will generate

## FM 6-60

a FM;CFF Priority 2 message. However, the commander may upgrade this to a Priority 1 message for certain CFFZs.

- The **artillery target intelligence zone (ATIZ)** is an area in enemy territory that the maneuver commander wishes to monitor closely. Any weapons acquired in this zone will be reported to the IFSAS computer ahead of all target detections except CFZ and CFFZ. However, the detections will result only in a target report (ATI;CDR).
- A **sensor zone (CZ)** is an area from which the commander wishes to ignore all target detections. The CZs must be used very judiciously, since the computer does not report to the operator a round originating from a CZ. A CZ may be used to ignore a friendly artillery position that, because of its aspect angle to the radar, could be detected as enemy artillery. This situation could occur when the FLOT is uneven or when friendly units are in enemy territory.

**Attack Criteria.** Firefinder generates only a target grid location and a mortar, type unknown (MORT UNK) or an artillery, type unknown (ARTY UNK) target description. Since Firefinder cannot discriminate between target size and specific type, the commander must establish specific attack criteria (for example, six M26 DPICM rockets for all mortar targets).

**Firefinder Restrictions.** Direct Firefinder-MLRS interface places several restrictions on Firefinder and MLRS usage as follows:

- The Firefinder's inability to discriminate beyond mortars and artillery prevents full use of the commander's engagement criteria.
- Firefinder digital nonsecure communications is highly susceptible to EW.
- The direct link of Firefinder and MLRS displaces IFSAS from the reporting loop. This prevents complete target analysis for artillery intelligence evaluation and counterfire assignment.
- Firefinder can generate more targets than one MLRS battery can handle with its nine launchers. Even a moderate, but constant, stream of Firefinder targets will place an enormous strain on the MLRS resupply system.

- Firefinder can generate more target information than the MLRS battalion TOC can process. To be responsive and to engage legitimate targets, the TOC must be augmented with targeting personnel.

**Optimum Use.** Direct Firefinder interface is best used when--

- Reduction of time from acquisition to firing is paramount (fleeting targets).
- Enough MLRS assets are available to handle the high volume of counterfire targets generated and/or enough ammo is available to support the fire mission load.
- Enough additional MLRS and other FA assets are available to engage all targets generated by other sources.
- Enemy EW capability is low.
- The force FA commander determines that only MLRS is necessary in the engagement of counterfire targets.
- Counterfire is determined to be the most critical requirement.

### OH-58D Helicopter

The FDS at platoon battery, or battalion can communicate digitally with an aerial observer in an OH-58D through the helicopter's ATHS. This link gives near-real-time target acquisition.

### Unmanned Aerial Vehicles (UAVs)

Both the U.S. Army and Marine Corps will be fielding the HUNTER system. This will penetrate into enemy airspace out to a range of 200 km to conduct reconnaissance missions. It has an endurance of eight to 12 hours of flight time. Both services currently use the PIONEER system. This UAV has a range of 185 km and 4-hour flight time. There is no organic data communications interface between these UAVs (and their C2 system) and the MLRS unit FDS. However, data communications can be established if the UAV company is supplemented with the Marine digital message system (AN/PSC-2A) or augmented with one of the two liaison sections from the MLRS battalion headquarters with their organic FED.



## Ground Station Module

MLRS battalions may be provided with a GSM in order to reduce “sensor-to-shooter” times during decentralized execution of delivery. The GSM receives target information directly from JSTARS airborne platform (E-8C), UAV and broadcast nets. These systems provide near-real time info on target location, description, speed, direction of travel and limited identification.

The GSM is a highly mobile-self-supporting system. Its prime mission is targeting, battle management, surveillance, and data processing. There are two variants

of this system, the medium GSM (MGSM), mounted on a 5-ton and a light GSM (LGSM), mounted on a HMMWV. Both systems are identical in capability except the MGSM cannot operate on the move. The GSM with the MLRS bn. gives the corps and division commanders immediate responsive attack capability against deep targets located by the E-8C radar system, UAV, and broadcast intelligence.

Targeting information received at the GSM is unfiltered raw data. It has not been processed by targeting or intelligence analysts for deception and target importance. Extensive commander’s guidance is necessary for the battalion to effectively engage HPTs.

---

## Section II OPERATIONS OTHER THAN WAR

---

Army forces and soldiers operate around the world in an environment that may not involve combat. This section describes the principles and tenets associated with Army operations other than war (see FM 100-5, Chapter 13 for detailed explanations).

The Army is often required, in its role as a strategic force, to protect and further the interests of the United States at home and abroad in a variety of ways other than war. Operations other than war (OOTW) often are of long duration and undergo a number of shifts in direction during their course. In operations other than war, victory comes more subtly than in war. Disciplined forces, measured responses, and patience are essential to successful outcomes.

Operations other than war may precede and/or follow war or occur simultaneously with war in the same theater. They may be conducted in conjunction with wartime operations to complement the achievement of strategic objectives. They are designed to promote regional stability, maintain or achieve democratic end states, retain US influence and access abroad, provide humane assistance to distressed areas, protect US interests, and assist US civil authorities.

The Army conducts such operations as part of a joint team and often in conjunction with other US and foreign government agencies. Army soldiers serve daily in this capacity: engineers help host nations build roads and improve infrastructures; military police (MPs) assist in the restoration of civil order; medics provide inoculations and advice for preventing disease; mobile training teams

enhance local militaries’ expertise in securing their nations’ interests.

OOTW will not always be peaceful actions. Determined opponents may resort to fighting or other aggressive acts in an attempt to defeat our purposes and promote theirs.

The OOTW environment is a complex one that will require disciplined, versatile Army forces to respond to different situations, including transitioning rapidly from operation is other than war to wartime operations.

### The Principles

Operations other than war have principles that guide our actions. Commanders must balance these principles against the specific requirements of their mission and the nature of the operation.

**Objective:** *Direct every military operation toward a clearly defined, decisive, and attainable objective.*

**Unity of Effort:** *Seek unity of effort in every operation.*

**Legitimacy:** *Sustain the willing acceptance by the people of the right of the government to govern or of a group or agency to make and carry out decisions.*

**Perseverance:** *Prepare for the measured, protracted application of military capability in support of strategic aims.*

**Restraint:** *Apply appropriate military capability prudently.*

**Security:** *Never permit hostile factions to acquire an unexpected advantage.*

**The Activities**

Operations other than war (see Figure 3-1) include, but are not limited to the following:

- Noncombatant evacuation operations.
- Arms control.
- Support to domestic civil authorities.
- Humanitarian assistance and disaster relief.
- Security assistance.
- Nation assistance.
- Support to counterdrug operations.
- Combating terrorism.
- Peacekeeping operations.
- Peace enforcement.
- Support for insurgences and counterinsurgencies.
- Attacks and raids.

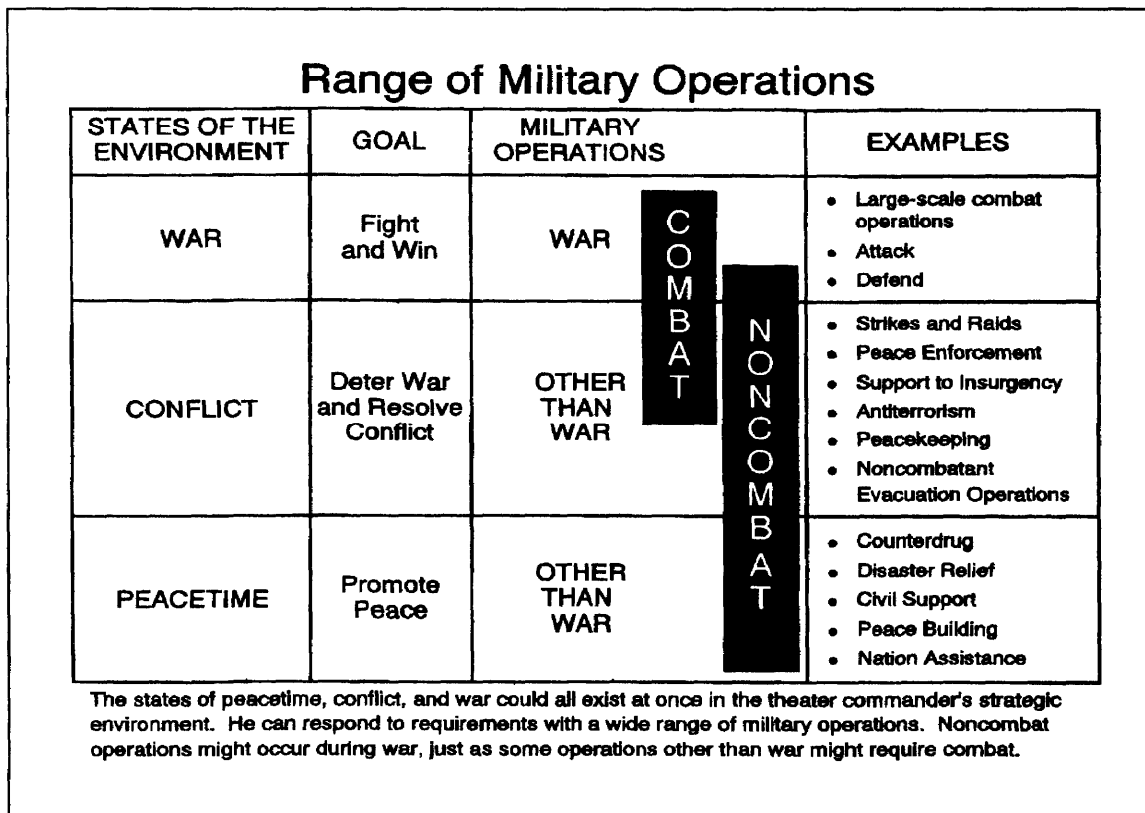

**Figure 3-1. The range of military options.**

## Roles of the MLRS Unit

The primary function for MLRS in OOTW is in the resolution of conflict phase. MLRS units may also support OOTW in a non-combat support role, as a show of force/resolve, or in a direct action role by attacking high payoff targets.

### Non-Combat Roles

In a non-combat support role, the MLRS unit may use its organic communication capability to support the task force command and control structure. The unit's M985 HEMTT offers unique logistical support capabilities.

As a show of force/resolve, the presence of the MLRS system in support of peace enforcement or peacekeeping missions demonstrates the nation's commitment to the mission.

### Combat Roles

Supporting peacekeeping or peace enforcement operations in a direct action role, the MLRS system can engage HPTs at extended range. When working with the Firefinder radar system, MLRS can effectively neutralize mortar and artillery firing positions in accordance with rules of engagements established by the joint task force.

The Army conducts attacks and raids to create situations that permit seizing and maintaining political and military initiative. Normally, the US executes attacks and raids to achieve specific objectives other than gaining or holding terrain. Attacks by conventional ground, air, or special operations forces, acting independently or in concert, are used to damage or destroy high value targets or to

demonstrate US capability and resolve to achieve a favorable result.

Section I of this chapter details some considerations for planning and executing participation in the raid (nonstandard employment techniques).

Tactics, techniques, and procedures specific to OOTW include:

- **Minimize Movement.** During OOTW the greatest threat to the force will usually be from small groups and terrorists conducting raids and ambushes. Occupation of a defensible firing position affords the MLRS unit with greater survivability in the OOTW scenario than does standard MLRS tactics of hide, move, and shoot.
- **Collocate With Other Units.** Occupying positions in conjunction with other task force units provides the MLRS unit with an increased degree of protection against enemy small unit attacks. Coordination is the key to success.
- **Harden Vehicles.** Using engineer assets to harden the MLRS position will improve survivability. Weather and terrain will dictate if the unit berms up or digs down. In either case the key to success is prior planning and coordination with the supporting engineer unit.
- **Direct Link with Firefinder Radar.** When supporting the task force with counter mortar/counter battery fires, a direct link should be established between the MLRS unit and the Firefinder radar to improve reaction time. A positive method of clearing fires must be established and enforced.

## CHAPTER 4

**MLRS UNIT OPERATIONS**

This chapter addresses MLRS unit operations. This includes organization of the battalion staff for tactical operations, as well as firing battery operations. Instructions covering features of combat operations which lend themselves to definite or standardized procedures without loss of effectiveness should be covered by a tactical standing operating procedure (TSOP). A guide and checklist for preparing an MLRS battalion TSOP, is at Appendix D.

## Section I

**BATTALION OPERATIONS****Six Basic Tasks**

In combat, the field artillery MLRS battalion provides indirect rocket and missile fire support to the ground force or in the conduct of TMD. In order to accomplish this, the battalion must perform six basic tasks.

**Deploy**

This task represents the collective efforts of the unit as it transitions from a training environment. It is the initial stage of force projection operations. It involves the planning, coordination, and conduct of operations to move unit equipment and personnel to the operational theater by air, land, and sea.

**Deliver Fires**

This task represents the collective efforts of the entire gunnery team to successfully attack targets. It includes all liaison, survey, tactical and technical fire direction activities and the management of target acquisition information culminating in the successful delivery of MLRS rocket and missile fires. Management of target acquisition information may include controlling field artillery radar systems attached to the unit as well as military intelligence, joint, and national sensor system down-links under their operational control. It may also include processing and correlating targeting data with regard to commander's criteria and intent in order to initiate attack of HPTs with short dwell times.

**Communicate**

Communication in MLRS battalions is critical to providing fire support. This is especially true with the reliance on automated system for data processing and fire direction functions. Both the dispersion of subordinate

elements and the distance to controlling/supported headquarters challenge the battalion organic communications assets. The communications system must satisfy the needs for command and control, movement, liaison, delivery of fires, and logistics.

**Move**

Positioning and movements of MLRS units require detailed planning and extensive coordination. In addition to ensuring continuous fire support, the plan must support the force commander's intent, consider security, and limit impact on the tactical maneuver commander's maneuver area.

**Maintain and Resupply**

Maintaining and resupplying the MLRS battalion is essential to sustaining the combat power of the unit and of the force as a whole. Chapter 6 discusses this task as a part of CSS operations.

**Survive**

To provide the support, the battalion must survive. The unit must implement tactics, techniques, and procedures that enhance the unit's ability to survive. These include everything from the avoidance of detection by the enemy to conducting detailed operational decontamination of personnel and equipment and effectively employing maneuver security forces under the operational control of the unit.

**Battalion Headquarters**

The MLRS is an extremely versatile and flexible system. Therefore, the MLRS battalion commander must consider several options when organizing the staff for tactical

## FM 6-60

operations. In addition to the factors of METT-T, he must consider survivability, dispersion, support requirements, past experience, and SOPs. He can devise almost any option to accomplish the unit mission. Several options are addressed below.

### Option 1--Dual CPs

The HHS is divided into a battalion CP and a battalion trains. At the battalion CP, the Operations, Intelligence, and fire direction sections act as the TOC and provide C2 for the battalion elements and the primary comm link to the controlling force FA headquarters. The TOC also monitors and, if necessary, coordinates for logistical support through the ALOC for the forward elements of the battalion.

At the battalion trains, the ALOC coordinates and controls support operations. The battalion XO supervises the ALOC. The HHS HQ, trains, and ALOC are located in one area. See Chapter 6 for logistical support information.

This type of organization emphasizes a reduced signature of the battalion HQ and increased responsiveness of the battalion CSS system. The POL resupply, maintenance, medical treatment, ammo resupply, and other support operations are handled by the ALOC and/or trains personnel. Signal personnel may stay with the TOC.

### Option 2--Consolidated CP

The entire HHS, both TOC and ALOC with trains, is located in one position area. This option derives the greatest measure of local defense from organic elements and simplifies TOC and ALOC procedures and operations. However, if battalion ammo resupply operations are centralized at battalion level, the size and operational signature of the combined TOC, ALOC, and trains may facilitate the enemy locating, targeting, and attacking the CP.

### Option 3--Mixed CPs

The HHS is split into a battalion CP and a battalion trains as with Option 1. The commander moves some of the trains support elements to the battalion CP location and places them under the control of the TOC. He leaves the rest under the control of the ALOC to operate from the trains area. The primary objective is to move critical support as far forward as possible within operational and/or situational constraints and to provide greater security for the battalion CP.

## Battalion Tactical Operations Center (TOC)

Within the TOC there are three distinct but related operations: fire direction, operations, and intelligence (see Chapter 5 for more information on fire direction). Although the functions differ, they must work together to ensure effective delivery of fires. The S3 supervises the TOC.

### Operations Responsibilities

- Issue plans and orders.
- Establish liaison as required.
- Plan and coordinate all unit movements.
- Coordinate positioning with controlling FA headquarters or maneuver FSE.
- Record all significant events on DA Form 1594 (Duty Log).
- Maintain operational overlays.
- Maintain a situation map.
- Monitor and project ammo status and/or requirements.
- Establish communications on appropriate nets (see Chapter 7).
- Exercise staff supervision of unit NBC operations.
- Ensure operations security (OPSEC).

### Intelligence Responsibilities

- Enemy situation awareness.
- Terrain analysis.
- Intelligence information processing and coordination.
- Weather updates.
- Management of target-related information.

- Map control.
- Physical security.

### **Liaison Function**

Although the liaison section is not physically part of the TOC, the two teams provide the TOC an essential link to numerous supported, supporting, and adjacent headquarters and agencies. Corps MLRS battalions have an organic liaison section consisting of two liaison teams. One team includes the LNO, a liaison sergeant, and a liaison specialist. The other team consists of the senior liaison sergeant and the assistant liaison sergeant. Each team is equipped with a HMMWV with FM radios (ANVRC-92A), a PLGR, and a MLRS FDS. Divisional batteries do not have organic liaison teams. However, when divisional batteries are assigned a R or GSR mission, they must provide for liaison. This function may be accomplished by the battery commander, ammunition platoon leader, ISG, or another experienced NCO, depending on the situation. Liaison responsibilities include the following:

- Passing information on the tactical situation to the reinforcing battalion CP.
- Ensuring that both units establish radio nets for-
  - Exchanging orders, situation reports, and intelligence reports.
  - Passing fire missions.
  - Quick-fire nets, as required.
- Passing unit locations, ammunition status, weapon strength, target lists, and fire plans between the two units.

Liaison is a function rather than a position. As long as the functional requirement is met to the satisfaction of the commanders involved, exchange of LNOs is not absolutely required. If the two units choose to collocate CPs or FDCs, the liaison requirement has been met and no liaison officer is required. If both units are automated and digital communications are adequate, a liaison officer may not be necessary.

When a corps MLRS battalion is assigned a tactical mission of GS, it will normally still be positioned in the area of operation of a maneuver brigade. The commander may consider sending one of his liaison teams to the

maneuver brigade FSE. This team can assist the battalion commander in tracking the maneuver situation and in keeping the maneuver commander informed of the location and status of a sizable friendly force that is in his area but not under his control. When supporting a MAGTF, the Marine controlling FA headquarters will provide a reciprocal liaison to the MLRS unit (see Appendix E, *LNO Checklist*).

### **Battalion Administrative and Logistics Operations Center (ALOC)**

The ALOC monitors and coordinates all tactical logistics functions affecting the MLRS battalion and its subordinate or attached units. The Bn XO executes overall supervision of these functions with the S1, S4, and select members of the special staff directly coordinating and controlling service support activities in these functions:

- Manning.
- Arming.
- Fueling.
- Fixing.
- Moving.
- Sustaining soldiers and their systems.

#### **Manning**

The Bn S1 is responsible for personnel readiness, replacement, and casualty management. Included in these are:

- Personnel strength accounting.
- Replacement management (assignment and requisition).
- Casualty reporting and management.

#### **Arming**

The Bn S4, in coordination with the TOC and battery LOCs, is responsible for ammunition management and resupply (including small arms and MFOM) in support of MLRS battalion operations. Key considerations are MSR

## FM 6-60

deconfliction, threat, and projected operational tempo (OPTEMPO) driven requirements.

### Fueling

The Bn S4, again in coordination with the TOC and battery LOCs, is responsible for ensuring the battalion's Class III (bulk and package) on hand quantities are sufficient to facilitate current and future operations. Key considerations are main supply route (MSR) availability, threat, and project unit moves (frequency, speed, and distance).

### Fixing

The BMO and battalion maintenance technician (BMT) are responsible for recovery, evacuation, and overflow from unit maintenance collection point (UMCP), to direct support units (DSU) locations, as required, organizational level repair of unit tactical and combat vehicles and engineer equipment. He directs the activities of the Bn maint section and DS unit MSTs. Additionally, he is responsible for coordinating Class IX repair parts availability. The BSO, although normally forward at the TOC, coordinates commo maintenance support.

### Moving

The Bn S4 is responsible for coordinating external augmentation of unit organic capability as required.

### Sustaining Soldiers and Their Systems

There are five elements to sustaining soldiers and their systems. Responsibility for these is shared across the staff--specific staff proponentcy.

Element	Proponent
Personnel Services	S1, Chaplain, Legal
Health Services	S1, PA
Field Services	S4, PBO
Quality of Life	S1, CSM
General Supply Support	S4, PBO

### Functional Command Post

The battalion TOC and ALOC must be organized to conduct sustained 24-hour operations. The purpose of the functional CP is to standardize the functions and equipment within the command post organization of units.

Current functional diagrams for the MLRS battalion CP are in Appendix F. These diagrams use personnel and equipment authorizations in the current objective L-series TOE and are designed to--

- Improve effectiveness in executing C2 functions.
- Improve C2 interoperability.
- Improve application of limited CP resources.

The MLRS battalions should use these diagrams as a source for developing tactical SOPs and for determining specific materiel and personnel requirements and training programs for CP sections and individuals.

---

## Section II

### MLRS FIRING BATTERY OPERATIONS

---

#### Battery Headquarters

The MLRS firing battery is the basic unit of employment of the MLRS. This chapter addresses battery employment and operations. Platoon-level operations, which differ from battery-level operations, are addressed in Section 3. Instructions covering features of combat operations which lend themselves to definite or standardized procedures without loss of effectiveness should be covered by TSOP.

(For a guide and checklist for preparing an MLRS battery TSOP, see Appendix D.)

The battery HQ provides command, control, and logistical support to the battery. The command element and the BOC provide the command and control. The rest of the headquarters has the assets to enable the battery to function independent of any battalion control. The elements and sections organic to the battery HQ perform

almost all service support functions normally associated with the battalion.

### **Battery Operations Center (BOC)**

The battery operations officer supervises the BOC. The BC can establish a BOC staff whose shifts may include the operations officer, the ammo platoon leader and sergeant, the fire direction computer, the NBC NCO, and the supply sergeant.

The BOC operates in the FDC armored CP carrier tent extension. The battery and battalion command (voice) nets can be remoted to field tables in the extension. The BOC establishes communications with the essential HQ elements. The BOC personnel maintain situation maps and overlays. They maintain SCP, ammunition, maintenance, and similar status charts and post other operational information in the tent extension.

**Operations.** The MLRS BOC is the C2 center of the battery. The BOC directs all battery operations in coordination with the battery commander. It directly controls FDC, survey, and NBC operations. It monitors ammo and launcher status and directs battery internal and external logistics and support operations. The BOC passes movement orders and other information to the subordinate platoons directly to platoon HQ.

**Fire Direction.** The MLRS firing battery FDC operates as a sub-element of the BOC. With the FDS, it controls all tactical fire direction.

### **Logistics Operations Center (LOC)**

The battery LOC is the primary C2 center for all admin-log operations, maintenance, and battery defense. It coordinates to procure external support and directs internal admin-log operations to include resupply. The LOC accomplishes these tasks in accordance with (IAW) priorities set by the BOC. The ammunition platoon leader/sergeant and/or 1SG directly supervises LOC operations.

## **Split Headquarters Operations**

### **Considerations**

There are basically two options for employment of the battery headquarters; dual and consolidated. Food service, supply, communication, and maintenance sections may be consolidated with the BOC at the battery HQ. When

consolidated, wire communications should be established between the LOC and the BOC. The BOC is the focal point for support requests, planning, and coordination. Dual headquarters operations can be accomplished by the firing battery establishing a battery trains with a LOC as a logistics command post. The LOC activities are still directed by the BOC. The commander decides which assets to deploy with the LOC and which to leave with the BOC. Commanders should consider the following when organizing their command posts.

**Terrain.** An elevated location is needed by the BOC for communications. The logistics elements (ammo platoon, maintenance, and supply) require a good road network and firm ground. If these two needs cannot be met at the same location, the commander may choose to separate the elements; for example, he may place the BOC on a hill and the trains in a nearby town.

**Enemy.** Because of enemy counterfire or air attack capability, the commander may choose to split operations. The BOC's large signature may jeopardize the entire headquarters.

**Communications.** Distance increases C3 and defense challenges and requires the LOC to monitor the battery command or other designated frequency. The radio in the ammo platoon's HMMWV can be used to monitor the net. This restricts, however, the use of the vehicle. When the LOC is located near the BOC (within 200 m), wire line communications can be used between the two operations centers. This reduces C3 problems and the electronic signature.

## **Battery Headquarters Positioning Considerations**

### **Battery Operations Center**

The BC or first sergeant should locate the BOC on elevated terrain for communications. It should be in the center of the headquarters position for maximum protection against ground attack.

### **Food Service**

This section should be located on firm, accessible ground; should have good drainage; and should be upwind from the field latrine. The food service section machine gun and cargo truck should be positioned to cover critical areas of the headquarters position, such as an avenue of approach.



## FM 6-60

### Maintenance Section and Direct Support Attachments

This section should be placed to cover a portion of the defensive perimeter and to allow maintenance vehicles to move in and out easily in support of the platoons. The maintenance (maint) section has a .50 caliber machine gun mounted on the recovery vehicle and an M60 machine gun. Both should be sited and used for position defense or emplaced at an LP and/or OP. The section also should be heated on firm, accessible ground that gives dispersion of the section vehicles and vehicles being repaired and recovered. Maintenance recovery vehicles usually move last in the march order.

### Supply

This section requires firm terrain as well. The supply vehicles (not including the POL tankers) are placed to cover a portion of the headquarters position. The supply and POL vehicles are placed for easy access to and from the position. The supply section has an M60 machine gun which can be emplaced as part of the position defense or on an LP or OP.

### Ammunition Holding Area

The AHA should be adjacent or closest to the MSR. It should be large enough to hold all of the battery HEMTT-HEMATs. It should be easily located, in darkness or daylight, by the ammo platoon personnel. Placed closest to the main supply route (MSR), the AHA controls the main access route into the area.

### Other Headquarters Elements

The rest of the headquarters platoon usually locates near the BOC. The NBC NCO works in the BOC, while the commander's vehicle and tent usually are located within 50 m of the BOC. The PADS survey section should be located within easy access of the BOC.

## Battery Defense

### Threat Capabilities

The enemy will direct actions against the field artillery to suppress, neutralize, and/or destroy our capability to fight.

**Detection.** Detection is done through the study of our doctrine and the processing of SIGINT, imagery intelligence (IMINT), and human intelligence (HUMINT).

- **Signals Intelligence.** Using signal intercept and radio direction finding (RDF) equipment, the enemy collects various FM and amplitude modulated (AM) radio transmissions. Tactical FM radios operating on low power can be picked up by enemy RDF units at distances in excess of 10 km. High-power signals can be detected at distances up to 40 km. However, directional antennas and reduced radio usage will improve survivability. Radars can detect firing weapons to a 200 m accuracy. Seismic and sound ranging can produce targets within 150 m. However, their accuracy is diminished by other battle noise.
- **Imagery Intelligence.** This effort consists of photographic imagery, thermal detection, radar location, and laser imagery. Unless assigned as a special mission, the processing of IMINT requires six to eight hours. Target location error from IMINT is 200 m.
- **Human Intelligence.** Long-range patrols, spies, partisans, and enemy prisoners of war (EPWs) are the HUMINT collectors. Although HUMINT relies primarily on visual observation, the peculiar equipment, predicted activities, bumper marking, spoils of war, and rubbish that is left behind add to the accuracy of the targeting effort.

**Attack.** A battery can be suppressed and destroyed by the following:

- Counterfire.
- Air attack.
- Ground forces.
- Electronic Warfare.

### Headquarters Position Defense

The primary method of survivability for an MLRS firing battery is to avoid detection. The battery headquarters should use natural and manmade camouflage, noise and light discipline, and terrain to reduce the risk of detection from the ground or air.

The battery headquarters should position .50 caliber machine guns, M60 machine guns, antitank weapons, and M203 grenade launchers to orient on likely enemy avenues of approach. The listening posts (LPs) and observation posts (OPs) should provide sufficient early warning to the battery.

The BOC must stay attuned to the current tactical situation and ensure that information is disseminated to all battery elements. Especially important is information pertaining to enemy locations and disposition, friendly units in or near platoon OPAREAs, the NBC threat, and locations of friendly and enemy minefields.

### **Defense Against Armored or Mechanized Force**

The best defense against an armored or mechanized ground attack is for the MLRS platoon to move to a position from which it can continue the mission (alternate OPAREA) without a direct confrontation with the enemy.

### **Defense Against Air Attack**

Concealment is the best defense against air attack. If the unit is detected and attacked, the key to survival is dispersion and engaging attacking aircraft with a large volume of fire. Fortunately, MLRS units are naturally dispersed, therefore providing enemy aircraft an elusive target. Normally, the MLRS unit will fall within the supported unit's air defense umbrella and may have air defense assets attached. This does not preclude the use of all available direct fire weapon systems in returning fire.

### **Defense Against Dismounted Attack**

Dismounted enemy elements will attack using:

- Special operations forces (SOF) using indirect fire.
- Ambushes.
- Guerrilla-type attacks (normally not exceeding platoon size and often conducted at night or in adverse weather).
- A diversionary attack and then a main attack.
- Dismounted infantry.

The best defense against a dismounted ground attack is to displace to an alternate position. In some situations, where the counterfire threat is minimal, launchers may operate from mutually supporting hide areas. These HAs may allow launchers to observe each other and provide early warning of dismounted ground attack.

### **Equipment and Materiel Destruction Procedures**

The BC must ensure that the unit SOPs include the procedures for the destruction of unit equipment and

materiel. He designates personnel to perform the destruction and ensures that adequate emergency destruction (ED) material is available. See TM 43-0002-16, FM 5-250 and STANAG 2113 for guidance in preparing unit SOPs.

## **Movement**

The MLRS battery displacement options resemble those of other FA units, however, the BOC directs and controls the displacement of subordinate platoons. The BC usually is directed to displace by battery, battery echelon, or platoon. Some considerations in selecting an option for displacement are as follows:

- Maneuver unit scheme of movement.
- Continuous fire support (fire plans/targets).
- Overall tactical situation.
- Immediate and future requirements of the supported unit.
- Characteristics of the terrain to be traversed.
- Distance of march.
- Time available
- Enemy capabilities.
- Command and control capabilities.

### **Displacement by Platoon**

This is the most common and preferred method of MLRS displacement for divisional MLRS batteries. One firing platoon at a time is displaced, either as a complete platoon or by individual vehicle infiltration.

### **Displacement by Battery Echelon**

In this method, one or two of the major elements of the battery are moved in two or more groups, such as two firing platoons. Then elements of the battery HQ or ammo platoon and the rest of the battery are moved.

### **Displacement by Battery**

This method, displacement of the entire battery at once, is the least preferred for divisional MLRS batteries, but, may be preferred for MLRS battalions. Distance, mission,

## FM 6-60

route priorities, or the overall tactical situation may dictate a battery-level move.

### Jump Battery Operations Center

Each BOC tries to maintain C3 and fire direction processing while moving. This is not always possible. A firing platoon can assume control of the battery as the headquarters displaces or if the FDS becomes non-mission-capable. The platoon FDS enters the digital net with the div arty TACFIRE/IFSAS, MLRS battalion FDS, or corps TACFIRE. Once this link occurs, the platoon assumes the role of battery FDC. The BC must ensure continuity of C2.

### Tactical Marches

A tactical march is the movement of a unit or elements of a unit under actual or simulated combat conditions. There are several methods for moving an element in a tactical configuration. Each method has specific advantages and disadvantages. The BC decides which method or combination is best.

#### Open Column

The open column is used for daylight movements when there is an adequate road network that is not overcrowded, when enemy detection is not likely, when time is an important factor, or when the travel distance is great. A vehicle interval in an open column is generally 100 m.

The **advantages** of the open column are as follows:

- Speed (the fastest method of march).
- Reduced driver fatigue.
- Improved vision on dusty roads.
- Ease in passing individual vehicles.
- Ease in dispersing vehicles as a passive defense measure against an air attack.
- Less chance of the entire unit being ambushed.
- Less vulnerability to indirect fire.

The **disadvantages** of the open column areas follows:

- Greater column length requires more road space and more time to close on the OPAREA.

- Other traffic often becomes interspersed in the column.
- Communication within the column is complicated.

#### Close Column

In close column movement, the vehicle interval is less than 100 m. Close column is used to maintain maximum command and control during periods of limited visibility or when moving through built-up or congested areas.

The **advantages** of the close column areas follows:

- Simplicity of command and control.
- Less time to close on the OPAREA.
- Reduced column length.
- Concentration of defensive firepower.

The **disadvantages** of the close column areas follows:

- The column is vulnerable to enemy observation and attack.
- The strength and nature of the column are quickly apparent to enemy observers.
- Convoy speed is reduced.
- Driver fatigue is increased.

#### Infiltration

When the battery moves by infiltration, vehicles are dispatched individually or in small groups without reference to a march table. Though this technique is time-consuming and the vehicles are difficult to control, it is used when the enemy has good target acquisition means and quick reaction capabilities.

The **advantages** of infiltration are as follows:

- Vehicles are less vulnerable to hostile observation.
- Opportunities for cover are increased.
- Defense against air and artillery attack is provided.
- The enemy is deceived as to the size of the unit.

The **disadvantages** of infiltration areas follows:

- It is time-consuming.
- It is difficult to command and control.
- Vulnerability of small elements is increased.

### Terrain March

The terrain march is an off-road movement to reduce vulnerability and to avoid traffic. A unit using this type of movement should travel close to tree lines, along gullies, and close to hill masses. When enemy observation or interdiction by artillery fire or air attack is likely, a terrain march should be conducted. A unit may move safely on a road for some distance and change to a terrain march at a point where enemy observation becomes likely or vehicle congestion makes an inviting target.

The terrain march should be considered when traveling to subsequent positions, but first, the following factors should be considered:

- Displacement time maybe increased.
- Ground recon is required.
- Soil conditions and other natural obstacles may complicate this type of movement.
- Wheel or track marks to the new position maybe left.
- Extensive coordination is required to avoid traveling through other unit areas.

The MLRS unit employing the terrain march may move in open column, in close column, or by infiltration.

### Special Formations

Based on the theater of operations and the tactical situation, the BC may choose to move his platoons in a special formation such as a wedge or multiple wedge. This is most appropriate in a desert environment where there are few obstacles to movement, visibility exceeds several kilometers, movement is over extended distances, and/or there is a need to provide rocket fires while moving. Commanders should consider placement of vehicles to protect C2 elements and make most efficient use of available weapon systems for defense. (See Figure 4-1, page 4-10.)

## Conduct of the Movement

**Preparation** for the move should include the following actions:

- Conduct preventive maintenance checks and services (PMCS) of equipment.
- Recover wire.
- Replace section equipment in the proper storage areas.
- Remove overhead cover and camouflage.
- Load all service elements, such as mess and maintenance.

The **organization** of the column varies according to the tactical situation, the threat, and the position to be occupied. The following considerations apply:

- Vehicles should be arranged in an order that facilitates speed, occupation of the new position, and defense during movement and occupation.
- Preparations should be made for personnel in a convoy to return fire, if attacked.
- Key personnel and equipment should be dispersed throughout the column. This enhances command and control during attack and precludes losing a large number of critical soldiers and equipment to enemy action.

The following **control measures** help in the movement and are normally established by higher headquarters.

- The start point (SP) is a clearly defined initial control point on a route at which specified elements of a column of ground vehicles come under the control of the commander having responsibility for the movement.
- A checkpoint is a predetermined point on the ground used as a means of coordinating friendly movement. Checkpoints are not used as reference points in reporting enemy locations.
- The release point (RP) is a clearly-defined control point on a route at which specific elements of a

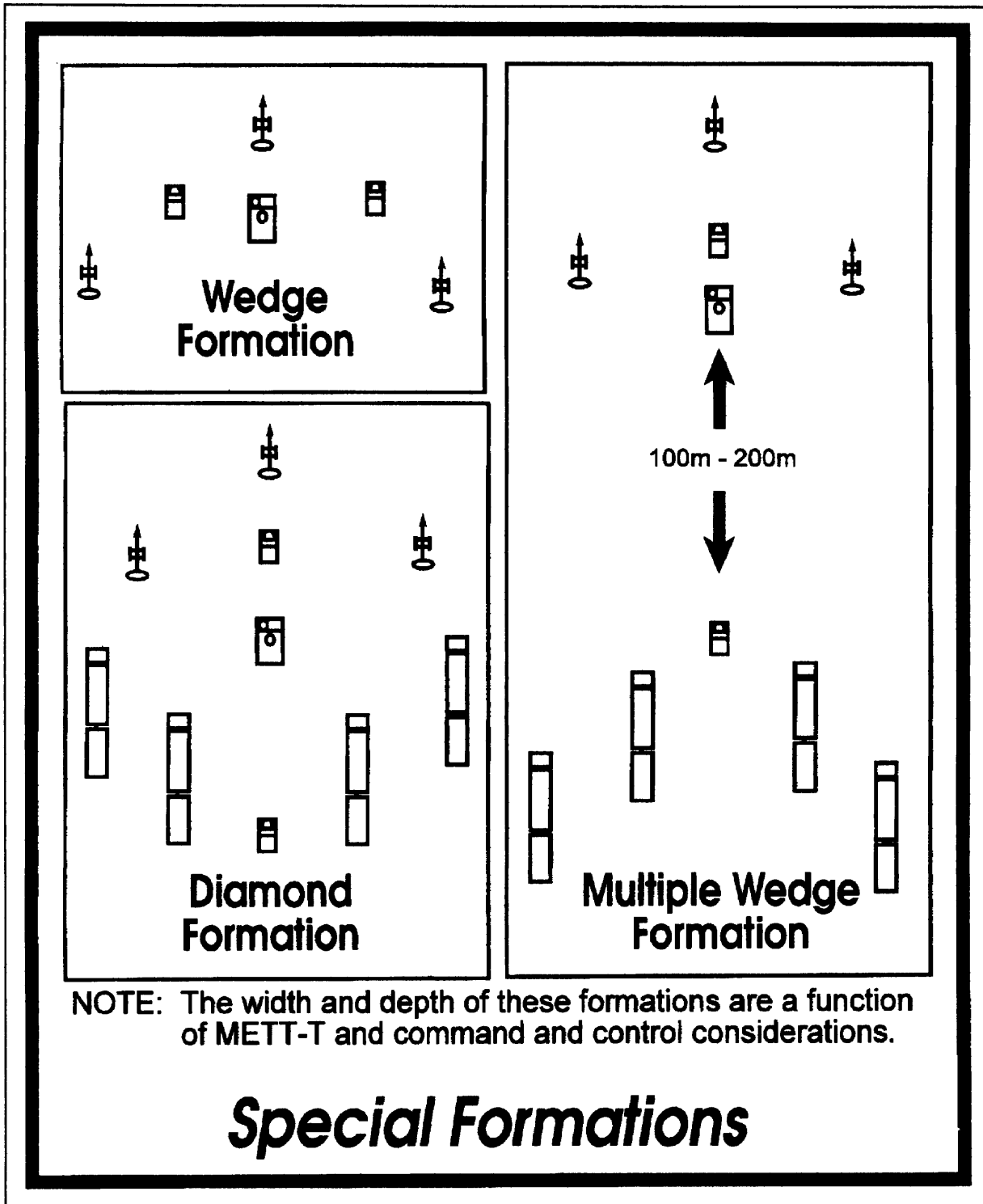

Figure 4-1. Special formations.

column of ground vehicles revert to their respective commanders, each one of these elements continuing its movement toward its own appropriate destination.

- A rally point is an easily identifiable point on the ground at which units can reassemble/reorganize if they become disbursed.
- A route-marking detail marks the route by posting signs and/or personnel at critical locations to guide the convoy. Details concerning traffic control and route marking are in FM 19-25 and FM 55-30.
- Predetermined signals, such as colored flags and flashlights, should be established by SOP to aid in convoy control.

### **March Discipline**

Officers and NCOs ride where they can best control and supervise the march of their units. The senior person in each vehicle is responsible for ensuring that all orders concerning the march are carried out.

The column must keep moving. The unit SOP should indicate who stops to pickup mission-essential personnel and equipment if a vehicle breaks down. Usually, the driver stays with the vehicle and the maintenance section stops to help. If the disabled vehicle cannot be repaired in a reasonable time or be recovered by the unit, the position and condition of the vehicle are reported to higher headquarters for recovery. To be available for the rest of the unit, the maintenance section must be prepared to proceed along the route of march independently and as soon as possible. The maintenance section and all other sections must have maps and must be thoroughly briefed concerning the route of march.

Each vehicle commander must watch for signs, markers, signals, and other traffic.

March discipline is attained through training and internal control within the marching unit. The specific objective of march discipline is to ensure cooperation and effective teamwork by march personnel as follows:

- Respond immediately and effectively to all signals.
- Relay all signals promptly.
- Obey traffic regulations and the instructions of traffic control personnel.

- Use cover, concealment, camouflage, dispersion, radio listening silence, blackout precautions, and other protective measures against air, ground, and NBC attack.
- Maintain correct speeds, positioning, and intervals between vehicles within the column.
- Recognize route-marking signals and signs.
- Use correct procedures for handling disabled vehicles.

During extended vehicle marches from rear areas to the main battle area (MBA), sites that provide cover and/or concealment should be selected for the halts needed to service equipment or to rest personnel. Security must be maintained at these locations.

### **March Column Contingencies**

#### **Immediate Action Procedures**

An MLRS firing battery or platoon is a high-priority target for the enemy. The MLRS units are most vulnerable to attack while moving, therefore, they must establish a SOP for defensive actions if attacked on the march. In establishing this SOP, the BC or platoon leader must consider the following:

- Enemy situation (kinds of attack to be expected).
- Organic resources available to counter each kind of attack.
- Nonorganic support available to counter attacks (fire support from FA units and so on).
- Amount of time available for training the unit in particular defensive actions (such as infantry squad tactics in response to a blocked ambush).
- Type of comm system to be employed with defensive actions (flags, radio, arm-and-hand signals, etc.).
- Means of protecting the battery or platoon.
- Methods to neutralize the attack.

#### **March Column Under Artillery Attack**

The defensive action in response to artillery fire is to move out of the danger area, report the situation to higher

## FM 6-60

headquarters, and request immediate counterfire. If a unit expects hostile artillery fire during the march, it can reduce its vulnerability by using one of the following methods of movement:

- Open column or infiltration.
- Movement during darkness or other periods of reduced visibility.
- Terrain march.

### March Column Under Air Attack

Under an air attack, the unit should immediately engage the aircraft with all air defense weapons available in the column. At the same time, it should disperse off both sides of the road and halt. High-performance aircraft can be effectively engaged with low-volume, independent, small-arms fire. As the aircraft approach, all personnel in the column should fire their weapons in the air two football fields (200 m) in front of the aircraft to form a wall of bullets through which the aircraft must fly.

### Roadblocks

When halted by a roadblock, the unit must apply, on both sides of the roadblock, the maximum amount of firepower available. If nonorganic support is available, such as close air support or covering artillery or armor, the convoy commander or controlling authority should request it immediately. If the roadblock cannot be neutralized, the unit must disengage under cover of supporting fires. Upon disengaging, the unit should meet at a designated rally point and then resume its march by using an alternate route. An attempt to crash through a roadblock with vehicles before the roadblock is checked for mines can result in unnecessary loss of equipment and personnel. The road may become completely blocked by disabled vehicles.

### Ambush

There are two types of ambush--blocked and unblocked. Both must be countered in the same manner: Get out of the kill zone, and neutralize the ambushing force with firepower.

If the route is blocked, maximum available fire should be placed immediately on the attacking forces. Personnel in the kill zone should dismount, attack as infantry, and

evacuate the kill zone as soon as possible. Convoy personnel not in the kill zone also must react immediately and outflank the ambushing forces.

In an unblocked ambush, the convoy should increase its speed and move through the ambush area while placing the maximum amount of small-arms fire on the attackers.

The area may have been identified during the map inspection as a likely ambush site, and on-call fires may have been planned. If so, the convoy commander or controlling authority executes on-call fires. Otherwise, he immediately sends a fire request to the FDC of the controlling FA headquarters.

The ambush or any other enemy action may be of such magnitude that the column is broken up. Then individual elements should go on their own to the position or designated rally points.

## Survey Support

Each MLRS firing battery has a survey section, equipped with one PADS. It provides survey control for the current and planned platoon OPAREAs. Each launcher section is equipped with a GPS device (AN/PSN-11).

Launcher crews use SCPs to initialize, update, and calibrate the launcher PDS. Although M270 launchers do not require directional control, there must be horizontal and vertical position control in each of the platoon OPAREAs. There may also be a requirement for establishing SCPs for conducting PDS calibration. The survey section establishes these SCPs with the PADS by using 10-minute Z-VEL (zero-velocity) corrections.

### Required Accuracies

There are different accuracies associated with SCPs for MLRS and required accuracies for firing. Although the SCP accuracy requirements may seem restrictive, they are based on the accuracy of the launcher SRP/PDS and the assumption that the launcher will move no more than 6 to 8 km between SCPs before conducting an update. The SCP accuracy requirements ensure that after the launcher moves 6 to 8 km the SRP/PDS will retain an accuracy within the prescribed MLRS firing point requirement. STANAG #2934 and QSTAG #269 define the MLRS SCP accuracy requirement as 8 meters CEP for position and 3.6 meters probable error (PE) in altitude (see Table 4-1).

**Table 4-1. Required Accuracies**

	CEP (POSITION)	PE (ALTITUDE)
MLRS SCP <sup>1</sup>	8 meters	3.6 meters
MLRS FP <sup>2</sup>	20 meters	10 meters
<b>Notes:</b> <sup>1</sup> QSTAG #269 and STANAG #2934. <sup>2</sup> The Army Positioning and Navigation Master Plan, 9 Sep 90.		

### System Accuracy

The two primary systems for establishing position control (PADS and PLGR) have different system accuracies (see Table 4-2).

**Table 4-2. System Accuracy**

SYSTEM	CEP (POSITION)	PE (ALTITUDE)
PADS <sup>1</sup>	7 meters	3 meters
PLGR <sup>2</sup>	10 meters	10 meters
<b>Notes:</b> <sup>1</sup> Updated using 10 min Z-VEL corrections. <sup>2</sup> Figure of Merit (FOM) of 1.		

Based on both the system accuracies of PADS and PLGR and the required accuracies established for SCPs and FPs, the PADS is currently the only means to establish position control at SCPs. The PLGR can be used to establish position control if the data is entered during an update at the FP from which the launcher will fire.

### Primary

The accuracy of the data produced by PADS is directly related to the accuracy of its starting data. MLRS units require fifth-order survey. Whenever possible, starting data for the battery PADS should be at least of fourth-order accuracy (see Table 4-3). These data can be obtained from higher headquarters, trig lists, or from other artillery units operating in the same area as the MLRS unit. When surveyed starting data are not available, use alternate methods described below. Survey control is provided to the platoons by the battery survey team. The points the battery survey team establishes should be considered SCPs. Ideally, the SCPs are located on readily identifiable and accessible terrain, such as road junctions. The launcher personnel must be able to locate each point and stop the launcher at the SCPs without excessive maneuvering. Within platoon OPAREAs, SCPs for launcher updates are established at the reload points. The

POC personnel give SCP coordinates and altitude to each launcher section and the PADS survey section. They also leave these data on a tag at a marker to identify the SCP.

**Table 4-3. Position Specifications**

	4TH ORDER	5TH ORDER
<b>ACCURACY</b> (Units of error to similar units of survey):	1:3,000	1:1,000
<b>EASTING/NORTHING</b> coordinates computed to:	0.01 meter	0.1 meter
<b>HEIGHT</b> computed to:	0.1 meter	0.1 meter

The survey section is controlled by the BOC and directed to link up with the platoon leader requiring survey support. The locations of all SCPs are maintained on the BOC situation map or charts for future use. Upon completion of his survey mission, the PADS chief reports directly to the BOC for further instructions.

### Alternate

If there is no survey control, the platoon leader must establish alternate methods of survey. He uses one of the following options:

- Use the PLGR (AN/PSN- 11 ) to establish survey.
- Use adjacent unit SCPs or their survey assets to extend survey control into the OPAREA.
- Use SCPs outside the OPAREA. Depending on the number of SCPs and their distance from the firing points, this method may severely limit platoon operations, since launchers should be updated after 6 to 8 km of travel.
- Use the launcher SRP/PDS to establish SCPs in the OPAREA by transferring survey from other SCPs and known points. This method may create some accuracy loss (accuracy depends on the distance traveled by the launcher); however, it is as accurate as hasty survey techniques up to an 8 km transfer-distance, and it is faster.
- Use a hasty survey (a graphic resection) to establish SCPs. The steps for establishing survey control through graphic resection are described in Appendix G.
- Use map spotting. Well-trained map readers using graphic training aid (GTA) 5-2-12 often can establish



an SCP to the same accuracy as by using hasty survey techniques. Map spotting should be used only as a last resort.

## **Meteorological Support**

The launcher FCS uses all lines of the current computer met message to compute rocket firing data. Rockets are particularly sensitive to low level winds.

Met messages usually are received in a digital secure mode from the controlling headquarters TACFIRE/IFSAS and/or MDS. They are routed through the battalion or battery FDS and sent to the FCS. The battery FDS sends met messages to all launchers and platoon FDSs simultaneously.

The platoon FDS can store the message and retransmit it to a launcher if necessary. Both the platoon FDS and the launcher FCS can be manually loaded with met data through keyboard entry if required.

The FDS interfaces directly with the MDS or MMS. Current met information can be obtained by communicating directly with the MDS on the met section net. The MDS is deployed down to FA brigades, while the MMS is used by light infantry, airborne, and air assault division artilleries.

### **Met Message Space and Time Validity**

**Space Considerations.** The accuracy of a met message may decrease as the distance from the met sounding site increases. Local topography has a pronounced effect on the distance that met data can be reasonably extended. In mountainous terrain, distinct variations of wind occur over short distances. This effect extends to much greater heights than the mountain tops. Large bodies of water will affect both the time and space considerations of the met message due to the land and sea breezes and the effect of humidity on density (increases in humidity decrease air density). Met messages for artillery are considered valid up to 20 km from the balloon release point over gently rolling terrain. The validity distance decreases proportionally with the roughness of the terrain.

**Time Consideration.** The passage of time may decrease the accuracy of a met message because of the changing nature of weather. There are no specific rules for determining the usable time, since that determination will depend on the characteristics of the atmosphere, periods of transition, met section movement, personnel, supplies and equipment, and the altitude of the met

message required by the firing unit. When the weather pattern is variable, the usable time is variable. If a frontal passage is forecast for the area, the met section will take a new sounding after the passage of the front. When the weather pattern is stable, and is forecast to remain so, time between messages may be extended up to several hours or longer, depending on the time of day and existing weather conditions.

**Transition periods.** Periods of transition account for a portion of the time consideration. General guidance in preparing flight schedules for soundings is discussed below.

- During and just after sunrise, temperature changes occur as the atmosphere becomes heated. Temperatures are more stable throughout the afternoon. Therefore, soundings are performed more often (every two hours) in the morning and less often (every four hours) in the afternoon.
- As sunset approaches, the air cools rapidly. During this time, changing temperatures are monitored closely. Flight schedules may have to be adjusted (to one every two hours) as the atmosphere cools. The cooling of the air stabilizes about two hours after sunset. At this time, flights normally return to a schedule of once every four hours.
- During night and early morning hours, the atmosphere reaches maximum cooling and becomes stabilized. During this time, soundings could be taken at intervals that exceed two hours and four hour intervals between flights are common.
- Regardless of the above, the tactical situation and the immediate needs of the unit are the main considerations that determine sounding schedules.

**Criteria for Use of Meteorological Data.** The order of preference of various sources of met data (see Table 4-4) for use by MLRS units is:

- Current met message from a station within 20 km of the launch point.
- Current met message from the nearest station more than 20 km from the launch point.
- Met messages more than two hours old but from a station within 20 km of the launch points. A 4-hour old met message may be used except when day/night transitions or frontal passages are occurring.

**Table 4-4. MET Message Areas of Validity**

TYPE TERRAIN	AREA OF VALIDITY
LEVEL	20 KM RADIUS
MOUNTAINOUS	10 KM RADIUS
COASTAL	15 KM RADIUS

**Met Message Checking Procedures**

It is imperative that all personnel question any peculiarities noticed on their copy of a met message. Also, any time there is reason to doubt the timeliness and/or validity of a met message, the higher headquarters should be consulted. The battalion or battery headquarters will contact the source of the met message. Met section personnel are qualified to explain any message variations and/or to correct message transmission errors. Verbal dissemination of messages often induces copying errors, especially when a message is copied on paper other than the standard met message form. Message checking guidelines for personnel are covered in this section. Because the computer met message (Figure 4-2) is a record of actual measured weather conditions, it is likely to show drastic changes.

**Message Heading**

- Check date and time entries to insure that the met message data are current. If the message is more than four hours old, check with the met section. (The date and time are Greenwich mean time [GMT], not local standard time.)
- Check met station height.
- The identification line pressure and surface (line 00) pressure should be the same.

**Message Body**

- Wind speeds and directions should be fairly uniform with proportional changes in altitude.
- Large changes in wind direction (1,000 mils) or abrupt increases or decreases in wind speeds (10-15 knots) should be investigated.
- Temperature accuracy is difficult to evaluate. Erratic changes in temperature (e.g.  $\pm 20$  Kelvin) should be investigated.

Atmospheric pressures always decrease consistently from line to line. Pressure will never increase with height. Transposed figures are the most common errors in pressure values. If errors in pressure are determined, the met section must verify the corrected values.

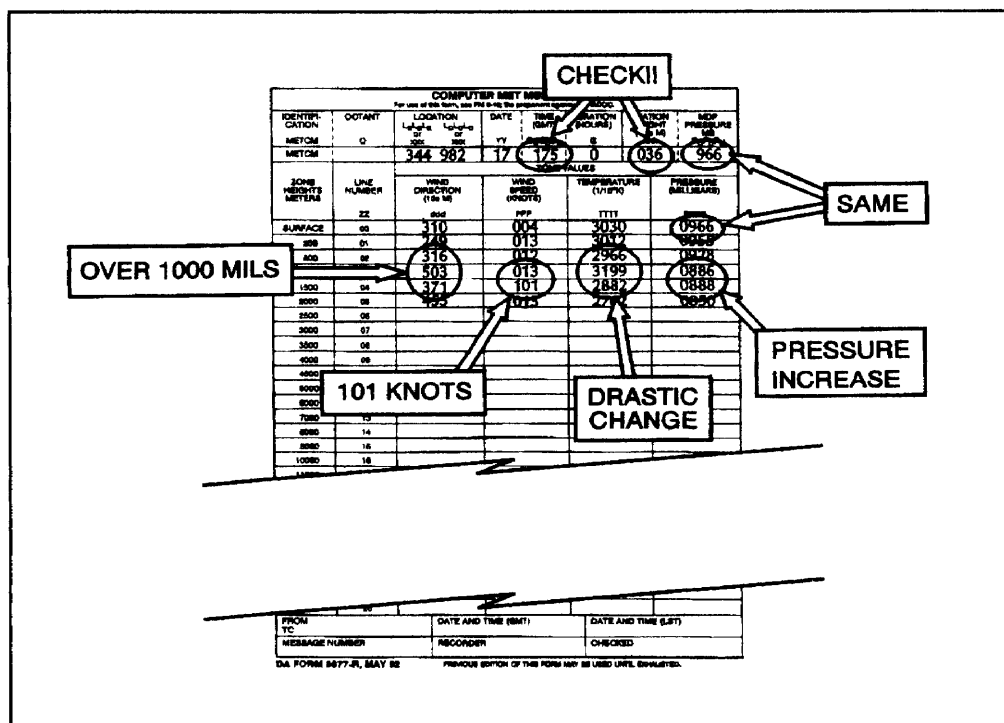

**Figure 4-2. Computer MET message.**

---

**Section III**  
**MLRS FIRING PLATOON OPERATIONS**

---

### **Platoon Headquarters**

The MLRS firing platoon conducts operations under the control of the battery, occupies a separate area of operations, and conducts its own RSOP. The MLRS firing platoon can be considered analogous to a cannon firing battery for fire support, positioning, and logistics considerations. Tactically, the platoon leader must do all of those tasks usually associated with the cannon battery commander. The leaders of the firing platoon must be innovative and creative in their approach to operations. The unique tactics of an MLRS firing platoon place great responsibility on personnel to meet their missions. Instructions covering features of combat operations which lend themselves to definite or standardized procedures without loss of effectiveness should be covered by TSOP. Preparation of MLRS platoon TSOPs is normally guided by a battery TSOP. (For a guide and checklist for preparing an MLRS battery TSOP, see Appendix D.)

### **Platoon Operations Center (POC)**

The POC is located in an armored CP carrier with an FDS. The POC is manned by MLRS fire direction personnel and is supervised by the platoon leader or the platoon sergeant. The recon sergeant also may work in the POC when he is in the platoon HQ position. The platoon leader or platoon sergeant should locate the POC on elevated terrain for communications and should center it in the platoon HQ position for maximum protection against ground attack and ease of platoon internal wire communications.

### **Command and Control**

The platoon leader and platoon sergeant are responsible for the command and control of platoon operations and for advising the BC and/or BOC on their launcher and ammo status. The BC and/or BOC directs the platoon leader and sergeant concerning the specific number of operational launchers that are posturing for specific munitions and ready to fire status. The platoon leader and platoon sergeant are responsible for coordinating all logistical support with the LOC. The POC personnel monitor all traffic between the BOC and the launchers by using the platoon FDS. Loss of the platoon FDC would severely hinder platoon command and control. The POC personnel maintain a DA Form 1594 and a DA Form 7232-R. A

reproducible copy of DA Form 7232-R is at the back of this manual. An example of an MLRS FDC Fire Mission Log is shown in Chapter 5. Fire Mission Logs should be maintained for one year as a record of live fire missions conducted.

### **Support**

The POC is the hub of platoon support activities. Any attached MSTs stay with the platoon HQ and are deployed IAW unit SOP. Launchers, in an inoperational (INOP) status, normally move to the platoon HQ area to reduce the security, command, control, and resupply burdens.

### **Operational Area (OPAREA)**

An MLRS platoon area should be large enough to allow a 3 by 3 km OPAREA by the platoon leader's map and ground recon (see Figure 4-3). Exact size of the OPAREA is a function of METT-T and a result of risk assessment. The tactical situation may require that platoons modify the size of the OPAREA. Smaller areas severely restrict the platoon leader's employment options, the length of time the platoon can occupy, and the survivability of the platoon. Regardless of the size, the entire OPAREA may not be used intensively nor exclusively. However, after use by MLRS launchers, the firing point (FP) areas may be subjected to intense enemy counterfire; therefore, they are considered highly dangerous. Except for cases of tactical necessity, launchers should use a firing point only once. The signature of the M270--noise, smoke, and fire--makes it easily identifiable from a great distance, especially in open terrain. Quality terrain is desired by all units, and parts of the MLRS platoon OPAREA can be used by other units. This often requires MLRS units to conduct face-to-face coordination with units on the ground. There are six types of positions within the OPAREA; each type may have several locations. The platoon leader or platoon sergeant must identify all OPAREA position types by grid during a recon. These positions are discussed below.

### **Firing Point (FP)**

Each platoon OPAREA should have at least nine FPs, three for each launcher. Each launcher section chief is

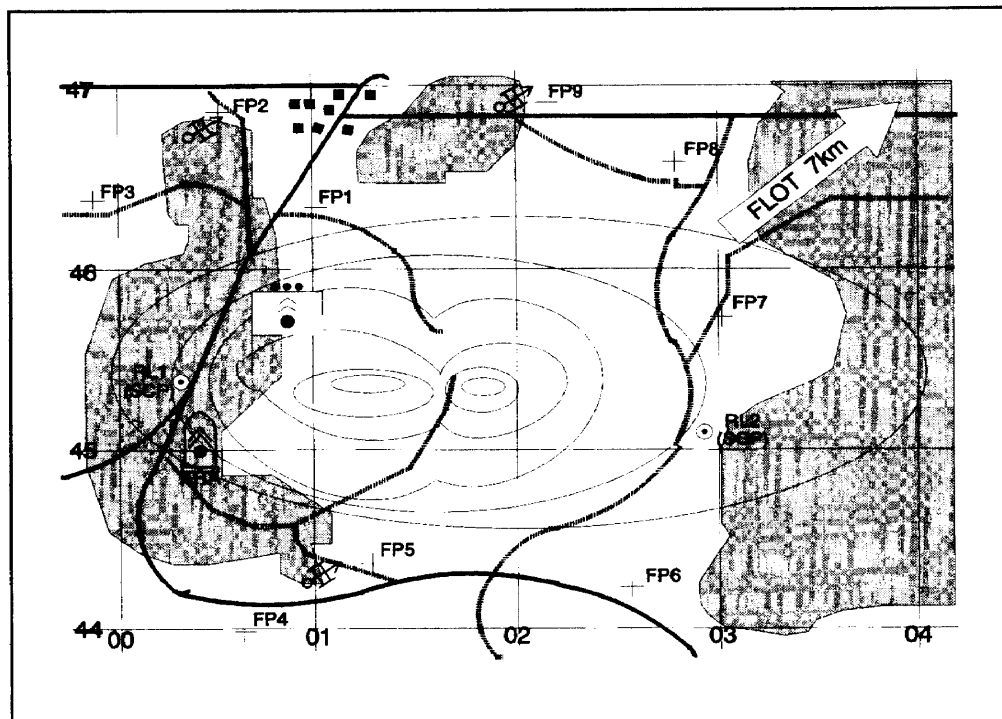

**Figure 4-3. Operational area.**

responsible for selecting his firing points. The following are considerations in selecting a firing point:

- The platoon leader is responsible for selecting firing areas. The section chief then selects FP locations (the launchers should not fire from slopes greater than 89 mils).
- There should be no immediate mask in the probable direction of fire.
- Hide areas (HAs) should normally be located within 100 m of the FP, however, longer distances are acceptable if response times can be kept short.
- The FP may be on a “reverse slope” of a terrain feature. Although masks should still be considered, reverse slopes break line-of-sight with the FLOT and may reduce the threat of attack by enemy direct fire systems during firing operations.
- The FP may be located on a road. For rocket missions, the road should be perpendicular to the general azimuth of fire. For missile missions, the road should parallel the general azimuth of fire. The road should lead directly to the RL or the next FP.

This reduces ground signature, response time, and time required to move.

- Communications must be established with the BOC and the POC.
- It should be 500 m from any other FP (800 m preferred) and 800 meters from any other position or element except HAs.
- For attack of critical, time sensitive targets with missiles, the launcher may be placed at my command (AMC) for extended periods of time (up to 2 hrs). FPs for these missions should also serve the purpose of a HA and provide concealment. These special FPs should be selected to enhance survivability while the launcher is laid on target waiting the command to fire.

#### **Hide Area (HA)**

The HA is selected by the launcher section chief. It is an area in which to hide the launcher while awaiting a fire mission. It should be a covered and concealed position close to the designated FP (normally not more than 100 m away). A launcher in the HA must be able to

## FM 6-60

communicate with the BOC. The HA can be on a road leading to the FP to reduce a ground signature and to speed response time.

### Reload Point (RL)

The RL is where the launchers upload launch pods and the HEMTT-HEMATs off-load. This is the most vulnerable point for each element. Each platoon OPAREA should have at least two RLs. The RL selection is based on the following:

- Cover and concealment for a HEMTT-HEMAT and launcher in the position at the same time.
- Maneuver room for the 100-foot turning radius of the 55-foot-long HEMTT-HEMAT and boom operations.
- It should be at least 800 m from FPs and at least 500 m from any other element.
- Firm ground or pavement for supporting vehicles and launch pods.
- Covered and concealed route from AHA to RL.
- Trafficability.

### Survey Control Point (SCP)

The SCP is where the launchers update the PDS. At least two SCPs should be established in the OPAREA. These should be collocated with the RLs, to reduce travel time of the launchers. The same considerations, except in the area of Class V resupply, apply for SCPs as for RLs.

### Platoon Headquarters

Platoon HQ is where the armored CP carrier CP track, the platoon leader's HMMWV, the platoon sergeant's HMMWV, and, if attached, the 27M DS MST vehicles are positioned. Normally, INOP launchers (being serviced, crew resting, etc.) are also positioned here. Each platoon OPAREA should have a primary platoon HQ location and an alternate location, if possible. The platoon HQ location is based on the following:

- Optimum communications with the BOC and launchers.
- Cover and concealment.

- Communications mask between the position and the enemy.
- Defensibility with the AHA.
- Trafficability.

### Ammunition Holding Area (AHA)

The AHA is where the ammo section positions its vehicles while awaiting transload or delivery of ammunition. It can be collocated with the platoon HQ if the ground threat is greater than the air attack or counterfile threat. Otherwise, the AHA should be 100 to 300 meters from the platoon HQ and astride the main entrance route into the platoon HQ for entry control. The AHA is not an issue point for the firing sections. The AHA selection considerations are as follows:

- Cover and concealment.
- Trafficability.
- Maneuver room for the 55-foot-long HEMTT-HEMATs (100 ft turning radius).
- Proximity to the MSR.
- Defensibility with platoon headquarters.

## Launcher Survey Control

### Survey Control Points

Although cover and concealment are factors in SCP selection, utility should be the primary consideration. The SCP must be readily accessible so the driver can stop the launcher with the rear edge of the left drive sprocket aligned next to the SCP marker. The area and SCP marker must be such that the driver can position the launcher without ground guidance or excessive maneuvering. The SCPs should be collocated with a reload point, if possible. This allows rapid return of the launcher to operational status.

### PDS Calibration

Calibration of the PDS (at least every 30 days, replacement of SRP/PDS, change in operating conditions, or after track or suspension maintenance) corrects for errors caused by differences in track tension or by wear of sprockets and track components. It accounts for the characteristics of each specific launcher. The crew

calibrates the launcher PDS IAW the technical manual. The launcher, under specific operating conditions, requires two SCPs, 4 to 6 km apart with a straight route of travel between them, located to at least fifth-order accuracy. One point is used to initialize the PDS for location. The launcher is driven to the second SCP at about 40 km per hour, and the first set of calibration corrections is determined. The launcher is then driven back to the starting SCP, where a second set of calibration data is computed. If both sets of calibration data are within tolerance, the system is functional and an averaged set of data is used. Calibration is not normally conducted in the platoon OPAREA. The battery operations officer plans the calibration course (s) for the battery as part of his survey plan. They are normally centrally located behind the firing platoons. A valid calibration can be conducted with any weapon loaded when the appropriate cables (W19 and/or W20) are connected to the pod.

### PDS Update

Errors that are a function of time and total distance are corrected by means of PDS updates. The PDS allows an error of up to 0.4 percent of the distance traveled. Crews should update launchers every 6-8 km of travel.

### SRP Alignment

Errors that are a function of time are corrected through the use of periodic SRP realignments. Realignments are required every 11 to 60 minutes of launcher movement depending on the munitions type and whether or not the SRP is compensated (see SRP/PDS). If the launcher is moved with the SRP turned off or not stabilized, the position location capability is lost. The system must then be updated at an SCP and the SRP realigned before the launcher can respond to any fire mission requests. Initial alignment of the system takes about eight minutes. However, allowing the SRP to stabilize 2 1/2 additional minutes longer after SRP READY is displayed will increase the time before realignment from 15 minutes to 60 minutes for rocket munitions and from 11 to 28 minutes for the Army TACMS.

## Launcher Response Posture

A launcher response posture dictates its readiness to respond to fire missions. The commander determines how his unit launchers will be posturing.

The commander normally directs the platoons to have a specific number of launchers in hot operational (OPER) status. The number is based on guidance from the controlling FA headquarters, METT-T, total launchers available, ammunition available, crew available, and fatigue. The platoon gives the BOC information on crew and launcher status and decides which launchers to posture as directed. The platoons usually rotate their launchers through hot status, changing individual launchers and maintaining the total number of required hot launchers. Commanders may designate the response posture of entire platoons.

The two methods of posturing, tactical and technical posturing (see Figure 4-4, page 4-20) are discussed below:

### Tactical Posturing

Through several generations of software for the FCS and FDS, the terms *hot*, *cool*, and *cold* have come to indicate launcher action response posture.

**Hot.** Hot status indicates the launcher is fully capable of firing. Usually, the status is based on the launcher's electrical and mechanical systems, not on its location or ammunition load. A launcher may be hot and, therefore, mechanically capable of firing. However, it may not be on or near a FP; or perhaps it may not have any, or enough or the right type of ammunition aboard.

**Cool.** Cool status indicates a launcher is capable of firing but only after the SRP is aligned.

Cool status indicates the launcher SRP/PDS has been turned off but that all other systems are on and fully functional. To reduce long-term wear on the components, the crew enters the FCS auxiliary menu, selects SPLL COOL, and turns the SRP/PDS off. About eight minutes are required to align the SRP and return it to operational capacity when it is turned on again.

The FDS is notified of SPLL COOL status when the crew sends a LCHR LST launcher status message, indicating that the launcher is INOP--SPLL COOL. The FDS will not select an INOP launcher to fire.

**Cold.** Cold status indicates the launcher is not-mission-capable (NMC) for maintenance reasons or that one or more essential systems are shut down for maintenance, PMCS, crew rest, etc. If a cold launcher is mission-capable, it may take 30 minutes or more for it to respond.

**Response Postures**

POSTURE		LOCATION	RESPONSE TIME	REMARKS
TACT	TECH			
HOT	OPER	FP	Immediate	Oriented; awaiting FIRE command or amended CFF at extended aim.
		FP	2 Minutes	ONC
		HA	3 to 6 Minutes	
	MOBL	Moving from RL to FP/HA	6 to 8 Minutes	Munitions loaded.
		Moving from FP to RL	15 to 35 Minutes	No munitions loaded.
COOL	SPLL COOL	HA	12 to 20 Minutes	
		Platoon HQ	20 to 30 Minutes	
COLD	OPER	N/A	30 Minutes or more	PMCS, rest, or refueling.
	INOP	N/A	N/A	Unscheduled maintenance or otherwise out of action.

Figure 4-4. Response postures.

**Technical Posturing**

The launcher crew makes one or more entries into the FCS to notify the BOC of the launcher status and location. These LCHR LST messages are entered as launcher OPER or INOP. Additional explanatory entries and the launcher’s current location and altitude are entered.

**OPER.** Upon entering OPER into the LCHR LST message, the crew must choose a numeric code to further identify the launcher status. For OPER messages, these are location codes. When LCHR LST is sent, the FDS displays the launcher status (OPER or INOP), current ammo load, and code location (FP etc.). Code messages may be assigned by unit SOP; however, only the code number will appear on the FDS. For example, OPER 06 might indicate that the launcher is fire-mission-capable but is displacing with the platoon to a new OPAREA.

**INOP.** The crew usually sends an INOP LCHR LST message to the BOC when the launcher is NMC. Instead of indicating locations, like OPER codes do, INOP codes indicate reasons for the launcher being INOP. The codes may be assigned messages under unit SOP. The messages are displayed on the FDS when LCHR LST is transmitted. For example, INOP 07 might mean that the launcher is INOP if the crew is conducting PMCS or refueling.

**LCHR LST.** After entering the OPER or INOP codes, the crew must verify and enter the launcher’s grid coordinates and altitude for transmission to the FDS. LCHR LST is transmitted after the location fields are edited. The LCHR LST messages can also be used to send additional information. If a fire mission is stored in the FCS, the crew edits and transmits the fire mission target number. If no fire mission is stored, the target number is sent blank. The number and type(s) of rockets on board also can be sent. This updates the FDS on the launcher ammo load. If the LLM has been laid for a fire mission, the crew can transmit the azimuth of fire, quadrant elevation (QE), and fuze time. If the LLM is not laid, these data are all zeros.

**Fire Direction System Posturing.** The FDS shows launchers as either OP, PART, MOBL, COOL, or INOP. The MOBL, COOL, or INOP launchers are not considered by the FDS when selecting a launcher to fire. The FDS continuously displays each launcher status as well as the code location and/or reason for the status. This provides easy reference for the BOC personnel in determining the battery’s overall and individual launcher status and location. The FDS also can transmit a command message to a launcher, directing the crew to bring the launcher to a hot (OPER) status. This message automatically turns on the SRP/PDS to begin the process.

## Detachment of the MLRS Firing Platoon

The MLRS firing platoon can provide fires without its parent MLRS battery or battalion. Logistical support of the detached platoon is a significant challenge. For a short

time, a cannon battalion could provide limited support while the platoon's assigned ammo section provides short-haul Class V resupply. Detailed support must be planned and specific resources allocated to support the platoon before this type of mission is executed.

---

### Section IV

## RECONNAISSANCE, SELECTION, AND OCCUPATION OF POSITION

---

### Planning

Frequent moves are common to MLRS operations. Survival on the modern battlefield necessitates such tactics. The BC must anticipate movement and plan in advance for displacement. He must keep the controlling headquarters advised of all factors that will impact on the movement of a platoon, the headquarters, or the battery as a whole.

Because MLRS units are dispersed, firing platoons conduct their own RSOP and the BC and first sergeant conduct the recon and selection for only the battery HQ positions.

Platoon OPAREA reconnaissance is the responsibility of the platoon leader and the primary duty of the recon sergeant. The platoon recon party also may include the platoon sergeant in the platoon leader's absence and/or the ammo section chief (or his representative) to advise on AHA positioning.

### Method

The keys to successful RSOP are discipline, teamwork, and rehearsal. Battery and platoon RSOPs are executed in a four-step process.

The **first step** is to **prepare** for the upcoming occupation. Preparation will include a mission analysis to determine what the unit is required to do and how long it has to do it. The factors of METT-T are considered and troop leading procedures are initiated.

The **second step** involves **reconnaissance**. The time available will dictate the method of reconnaissance employed. The reconnaissance party is selected by the BC/1SG based upon the mission and unit TSOP. Ammo personnel are often included in recon parties to offer

advice on vehicle placement and provide additional defensive firepower.

The **third step** involves the actual **selection and occupation of the position** by an advance party. Again, METT-T and unit TSOP will dictate the size and composition of the advance party. Personnel on the advance party prepare the selected position for occupation by the main body and conduct a security sweep. Battery headquarters personnel conduct advance party operations. Firing platoons prepare their positions during reconnaissance operations.

The fourth step is the assembly, movement, and occupation of the position by the main body. The main body usually begins this step only after the advance or recon party, with its jump BOC or forward Plt HQ, has emplaced and is ready to transfer C2.

### Preparation

Preparation must include briefing leaders on the following:

- Mission.
- Tentative next locations.
- Proposed routes.
- Adjacent units.
- Possibly the designation of a POC as jump BOC if the BOC displaces and can no longer communicate.
- Enemy situation (threat to movement and occupation).

In planning the RSOP, an analysis of the factors of METT-T is essential.



## FM 6-60

### Mission

Providing responsive fire support is the overall mission. A key consideration for the MLRS battery commander is determining the movement technique (battery, platoon, or echelon) that best supports the fire support needs of the maneuver force.

### Enemy

All members of the battery must fully understand the enemy situation and related factors. An imminent enemy offensive requires increased MLRS fire support, which is degraded during moves. Enemy rear area incursions jeopardize moving elements; enemy target acquisition and counterfire capabilities may change the distance or frequency of displacement.

### Terrain

Terrain dictates time and distance requirements, primary and alternate routes, positioning possibilities within the assigned area, and many other factors.

### Troops

Commanders and platoon leaders must consider the availability of troops and their state of morale, rest, and training.

### Time Available

The maximum time possible must be allotted to MLRS commanders and leaders for the RSOP. However, the time available for RSOP changes constantly, and planning must include variations and contingencies.

## Reconnaissance

At least four recons are required to move the entire battery into a new position (one for battery HQ and three for the firing platoons). The three types of recon are map, air, and ground.

### Map Reconnaissance

The map recon is preliminary to the ground or air recon. Potential positions and routes to them are selected. This method is very fast; it allows unsuitable routes to be eliminated. Also, likely ambush sites, rendezvous points, checkpoints, and other pertinent locations can be identified

on the map. The major disadvantages of the map recon are as follows:

- Actual terrain conditions cannot be determined. Terrain features change with time, especially vegetation and the presence of manmade features. The map publication date should be checked.
- Surface conditions of the route and the position cannot be determined accurately.
- Other units maybe in the position.
- Enemy forces may be in the area.

### Air Reconnaissance

An air recon is made in conjunction with map and ground recons, whenever possible. If time and resources are available, information gained from an air recon is very useful. Air recons are faster than ground recons. However, they may give an inaccurate picture of the surface conditions and may reveal the route and the new position to the enemy.

### Ground Reconnaissance

This is the best type of recon because the routes and position can be physically examined. However, this is the slowest type of recon.

## Selection and Occupation of Position

### Battery Headquarters Considerations

The battery commander or first sergeant must consider many factors in the selection of the battery HQ area.

**Mission.** Mission is the most important consideration. The position must facilitate both C3 and logistical support to firing platoons.

**Tactical Situation.** The tactical situation largely dictates the following:

- Location and size of the position area.
- Whether or not the headquarters is split into separate BOC and LOC locations.
- The technique of positioning the vehicles.
- The use of terrain in defense of the unit.

**Communications.** The position must optimize communications between the battery HQ, controlling FA HQ, platoons, and launchers. Terrain communications masking will enhance survivability.

**Defensibility.** The position should permit both active and passive defense so that it--

- Can be entered without enemy observation.
- Offers good cover and concealment.
- Has more than one entrance and exit.
- Takes advantage of existing terrain features.

**Trafficability.** The soil must be firm enough to support the vehicles of the unit. If an urban location (town or village) is used, the street widths, bridge classifications/capacities, turning radii, and overhead objects must allow adequate clearances for the heavy and large battery vehicles.

**Weather.** Weather conditions and the effect of weather on the terrain must be considered.

**Road Network Availability.** The headquarters area should be on or near an MSR used by battery resupply and support vehicles going to and from the platoons, ATPs, ASPs, and supply distribution points.

**Other Factors.** Additional factors to be considered are as follows:

- Zone of supported force.
- Location of ATPs and ASPs.
- Location of maneuver units.
- Weather and trafficability in the supported zone.

#### **Platoon OPAREA Considerations**

One of the advantages of MLRS is that the system requires very little, if any, position preparation. The MLRS firing platoon uses no advance party. The position preparation that does occur is either completed during the reconnaissance or does not impact on operations and is completed after occupation.

The firing platoon has considerations beyond those discussed under the battery headquarters section:

- Communications with the BOC.
- Open areas for firing points.
- Dispersion requirements of platoon locations; for example, FPs, HAs, RLs, SCPs, platoon HQ, and AHA.
- Maximum cover and concealment for the platoon HQ, HAs, RLs, SCPs, and AHA.
- Trafficability within the OPAREA and location of the MSR.
- Availability of a road network to reduce ground signature.
- Traffic patterns for reload and other operations.
- No major terrain or manmade features interfering with OPAREA operations (rivers, major highways, cities, etc. . . .).
- Establish easily identifiable displacement routes from the OPAREA.

**Occupation.** Once the platoon sergeant arrives with the main body of the platoon, the platoon leader must ensure all launchers reload, update SRP/PDS, receive OPAREA data, and are thoroughly briefed on the OPAREA. The platoon sergeant should ensure all combat, command and control, and support vehicles are positioned IAW the platoon leader's guidance.

**Security.** Because of the limited number of personnel, lack of crew-served weapons, and large size of the platoon area, defense against a ground attack is limited. The platoon is a high-priority target for enemy ground maneuver and special operations forces. Since the platoon is normally positioned as close as possible to the FLOT in the maneuver brigade sector, security must be a high priority to avoid exposing the launchers and nearby maneuver units to enemy ground or indirect fire attack. The keys to survivability are the avoidance of detection

## FM 6-60

and passive defense. The platoon sergeant is in charge of the platoon area security and does the following:

- Coordinates with DS cannon and maneuver units within the OPAREA for direct fire support and early warning of imminent attack.
- Uses mines and trip flares if available (this requires extensive coordination).
- Gives a rendezvous grid to each launcher for use in case of hasty or emergency displacement.
- Places the M60 machine gun on the most likely avenue of approach to the platoon HQ (usually with LP and/or OP at the entry control point in the AHA).
- Has launcher chiefs dismount one man in the HA to provide local security, except during a fire mission.

### Masking Data

Masks are terrain features that have enough altitude to potentially interfere with the trajectory of the rocket or missile. There are two categories of masks: *immediate* and *downrange*. Immediate masks are within 2000 m of a launcher firing point and are measured and input to the FCS by individual section chiefs. Downrange (DR) masks are beyond 2000 m and are measured and input to the FDS by the platoon leader and/or battery operations officer IAW with unit operating procedures. Downrange masks are measured and applied in two ways: *Crest Clearance Tables* and *Automated DR Mask Checks*.

### Crest Clearance Tables

The tables at Appendix H allow leaders to establish a minimum planning range beyond a crest for launchers in a specific firing area to ensure that rockets will clear the crest and that warhead event will not occur until the crest is cleared. This is most significant when deployed in mountainous regions. The planning range derived from the tables can be used to establish the size of the area beyond a crest that cannot be attacked from a particular firing point or OPAREA with rocket munitions.

### Automated DR Mask Checks

Downrange masks can be entered in the FDS as three dimensional boxes around the terrain feature. They are then used by the FDS during tactical fire direction to determine if the target can be ranged from the launcher firing point (or platoon center) without striking a major terrain feature. The operations officer and/or platoon leader conducts a terrain profile analysis of the area and identifies terrain features that may interfere with the trajectory. He measures each of the terrain features in terms of altitude, width, and grid coordinates (see Figure 4-5). He then ensures entry of this data into the FDS database (see TB 11-7025-306-10-2). A consideration in using this method is that the three-dimensional box will normally be much larger than an existing terrain feature. This means that, although a terrain feature may not physically interfere with the trajectory, the described DR mask may cause the FDS to detect a violation. Leaders can reduce this effect by selecting the smallest acceptable value for DR mask width.

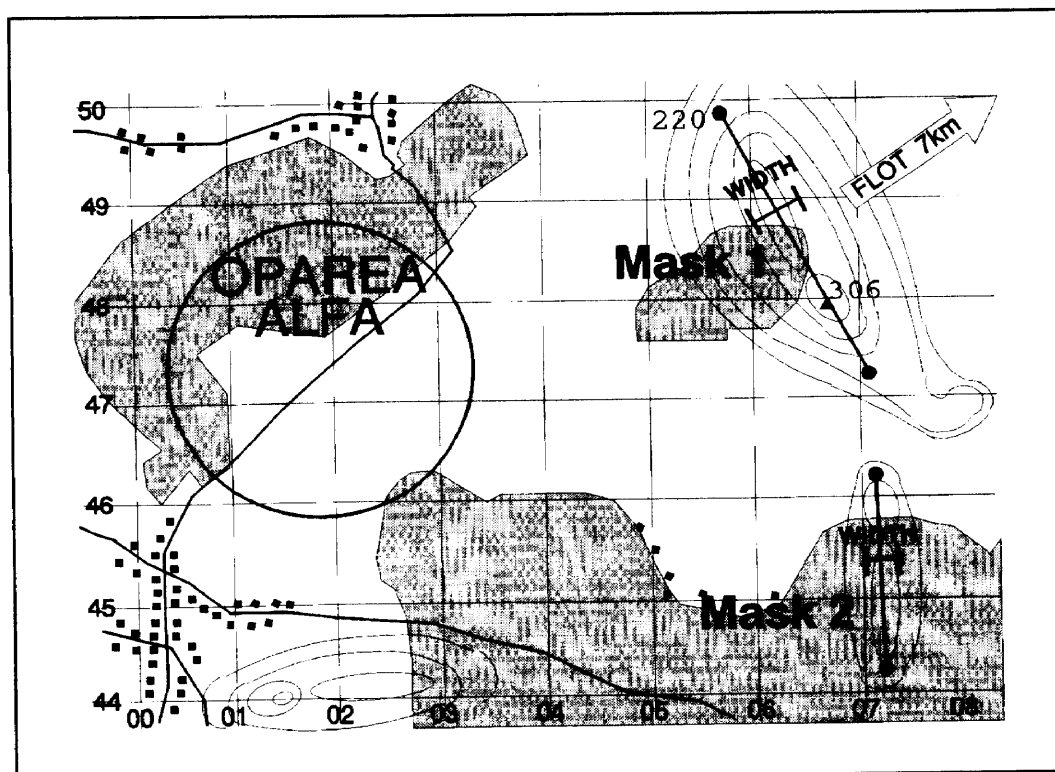

Figure 4-5. Masking.

Section  
V

## CONTINGENCY OPERATIONS

### Force Projection

In order to provide long range artillery fires for contingency forces, MLRS units must be capable of deploying anywhere in the world with little or no notice. The discussions in this chapter cover planning considerations for contingency operations and deployment. This chapter is not intended to be all inclusive but rather to highlight considerations when planning for contingency operations.

Force projection usually begins as a contingency operation--a rapid response to a crisis. Alert may come without notice, bringing with it a tremendous stress on soldiers and systems, accompanied by pressure from various external sources. In any event, rapid, yet measured response is critical.

The following are considerations when preparing a force projection package:

#### Lethality for the Deploying Force

An important consideration for planning contingency operations that involve possible combat operations is to introduce credible, lethal forces early. A tailored force with enough assets--to include long range indirect fire assets--might enable the force to deter the enemy from attacking. The ability to rapidly airlift MLRS assets makes MLRS a logical choice when long range, lethal, indirect fires are needed.

#### Anticipation

MLRS commanders must anticipate deployments in order to mentally and physically prepare units for force projection missions. Anticipating possible contingency

missions and planning for them reduces the amount of pressure and stress placed on soldiers and systems.

### **Force Tailoring**

Force tailoring is the process of determining the right mix of units and the sequence in which they are to deploy. MLRS commanders must be ready to deploy subordinate elements of their unit to support a particular force projection package.

### **Intelligence**

Early deploying units usually face a maze of complex information requirements--some relating to the enemy, others to local laws, availability of facilities, and similar considerations. Force projection operations need accurate and responsive tactical intelligence. In order to satisfy their intelligence requirements, MLRS commanders must determine the available sources and establish connectivity with appropriate agencies.

### **Logistics**

Successful force projection requires flexible logistics and support systems. MLRS commanders must consider all classes of supply and logistical support when preparing to deploy as part of a force projection package.

### **Training**

Demanding and relevant training is important. When alerted to deploy, MLRS units must build upon home station training by focusing on missions and conditions they expect to encounter in a particular contingency. Leaders must conduct mission essential individual and collective training during deployment and after arriving in the theater of operations (see Appendix I, *Section Evaluation and Training*).

### **Joint Operations**

Joint operations occur when multiple service and functional components combine efforts under a JTF. The synchronization of air, land, sea, space, and special operations forces is critical to effectiveness and ultimate mission accomplishment. MLRS units may support any of a number of components during joint operations. One of the most likely is MLRS support of a MAGTF. The exact size and composition of the MLRS unit to support MAGTF operations will be a function of METT-T. Normally, an MLRS battery or battalion will support a MEF or MEF Forward (MEF[Fwd]) based on METT-T.

## **Combined Operations**

Combined operations occur when two or more nations combine their efforts in a military operation. Force projection operations will almost always involve operations with other nations. MLRS commanders and soldiers should be sensitive to cultural differences that may impact their operations.

## **Deployment**

MLRS units are capable of deploying by air, land, or sea as part of an all Army force or as part of a combined arms force. Timelines for deployment will always be driven by METT-T. Generally, this timeline will be developed based on reverse planning done at higher headquarters. Factors that affect reverse planning include but are not limited to: aircraft availability; type, size, and amount of equipment, and personnel and equipment attached.

### **Air**

The MLRS system has the ability to be deployed by C141B and larger type aircraft. MLRS commanders must ensure their soldiers are familiar with aircraft loading procedures as well as with Air Force rules and regulations regarding transport of equipment.

### **Sea**

MLRS units must also be prepared to deploy their equipment by sea. This is especially true for follow-on forces. MLRS commanders should ensure that their units are familiar with all facets of sealift operations.

### **Land**

Often, units must move their equipment to a seaport by rail or heavy equipment transport (HET) then load the equipment onto ships. MLRS commanders must be familiar with specific vehicular requirements for transport and ensure that their soldiers are trained on proper loading techniques.

## **Deployment Packages**

Since contingency forces are tailored to meet the specific mission requirements of a force projection package, the possibility exists that only parts of MLRS units will deploy as part of a force projection package. These packages assume that a slice of C2 up to the BN level will accompany each package. This allows for more rapid

integration of follow-on elements of the battalion by having the structure in place. It also facilitates activities such as operational and logistics liaison with support from the battalion. Table 4-1 gives examples of possible MLRS packages that could be used to support difficult

contingency operations. These tables are general in nature and do not include detailed ancillary personnel and equipment requirements. These tables do, however, include approximate numbers of direct support maintenance equipment and personnel.

**Table 4-1. MLRS Contingency Packages**

<b>MLRS BATTERY (-) PACKAGE</b>	
<b>MAJOR ITEMS OF EQUIPMENT</b>	<b>QUANTITY</b>
M270 Launcher	3
Armored Carrier, CP	2
M88A1 Recovery Vehicle	1
M985 HEMTTT	6
HMMWVs	14
M978 Fuel Tanker	1
Cargo Trucks	8
<b>PERSONNEL</b>	
MLRS Unit	71
Maintenance Support Teams	25
<b>AIR FRAMES</b>	
C5A	8
C141B	13

<b>MLRS BATTERY (+) PACKAGE</b>	
<b>MAJOR ITEMS OF EQUIPMENT</b>	<b>QUANTITY</b>
M270 Launcher	9
Armored Carrier, CP	5
M88A1 Recovery Vehicle	1
M985 HEMTTT	12
HMMWVs	26
M978 Fuel Tanker	2
Cargo Trucks	10
<b>PERSONNEL</b>	
MLRS Unit	126
Maintenance Support Teams	40
<b>AIR FRAMES</b>	
C5A	12
C141B	24

<b>MLRS BATTALION (-) PACKAGE</b>	
<b>MAJOR ITEMS OF EQUIPMENT</b>	<b>QUANTITY</b>
M270 Launcher	18
Armored Carrier, CP	10
M88A1 Recovery Vehicle	3
M985 HEMTTT	24
HMMWVs	55
M978 Fuel Tanker	5
Cargo Trucks	23
<b>PERSONNEL</b>	
MLRS Unit	312
Maintenance Support Teams	67
<b>AIR FRAMES</b>	
C5A	16
C141B	44

<b>MLRS BATTALION (+) PACKAGE</b>	
<b>MAJOR ITEMS OF EQUIPMENT</b>	<b>QUANTITY</b>
M270 Launcher	27
Armored Carrier, CP	14
M88A1 Recovery Vehicle	4
M985 HEMTTT	36
HMMWVs	72
M978 Fuel Tanker	7
Cargo Trucks	26
<b>PERSONNEL</b>	
MLRS Unit	424
Maintenance Support Teams	73
<b>AIR FRAMES</b>	
C5A	47
C141B	3

## **Special Operations**

### **Operations in Mountainous Terrain**

More ammunition may be required to support the force in mountainous terrain because of reduced munitions effects. Cross-country restrictions force the enemy to use roads and trails, which will enhance interdiction fires. Additionally, mountainous regions may affect MLRS employment because of the low trajectory of MLRS rocket munitions. Leaders should use the crest clearance tables in planning platoon OPAREAs (see Appendix H).

C2 is degraded in mountainous regions because of decreased effectiveness of FM radio communications.

Movement control is more difficult on winding mountain roads. Occupation and displacement is also limited in these regions to the use of available roads, which generally are narrow and twisting. Terrain march may be impractical or impossible.

Logistics resupply is more difficult because of the limited number of roads and the slower convoy speeds. Survey may not be as accurate, and target acquisition may be limited by terrain masks. Ambushes are likely in this type of terrain.

### **Operations in Jungle Terrain**

MLRS is not normally appropriate for jungle operations. The system requires open firing areas and freedom of movement in order to maximize both its effectiveness and survivability. In addition to these fundamental limitations, jungle operations present problems because of the high humidity and dense vegetation. Humidity may reduce electronic equipment and launcher LRU operability. Dense vegetation degrades M77 munitions effects. In a thick canopy, DPICM is ineffective.

Communications equipment is degraded because of high humidity, vegetation density, and electronic line-of-sight restrictions. Antennas may have to be elevated to overcome line-of-sight restrictions.

Immediate masks are prevalent in jungle terrain. Selection of platoon OPAREAs and launcher firing points is hampered by soft terrain and thick vegetation, because the ground on available roads is soft and use of terrain march is restricted. This type of terrain is much more suited to light cannon operations than MLRS.

Logistics resupply is hampered by reduced mobility and survey control is more difficult to establish. Target acquisition accuracy is degraded because of heavy foliage. Launchers should be positioned closer together to provide for better security.

### **Northern Region Operations**

Northern operations are characterized by frozen earth, snow-covered terrain, intense sunlight, and prolonged darkness. Rocket and missile smoke trails last longer in cold weather, thus making launchers more readily identifiable to enemy TA assets.

Radio communications can be unreliable in extreme cold, and equipment may become inoperative.

Frozen, snow-covered terrain may limit the number of available positions for platoon OPAREAs. Mobility is slowed for headquarter elements, as wheeled vehicles and trailers generally are not suited for operations in northern areas. In extreme cold, metal tends to become brittle and parts breakage increases. Convoys must travel in a close column during whiteout conditions and prolonged darkness.

Logistics resupply is hampered by reduced mobility and difficulty in determining grid locations. Target acquisition equipment can be adversely affected by snowstorms and intense cold.

### **Military Operations on Urban Terrain**

The massive growth of urban areas and manmade changes to the landscape significantly affect the conduct of future battles. Commanders at all levels must be aware of the unique advantages and disadvantages associated with operations conducted in and around cities, towns, villages, and similar built-up areas. Special techniques may be used in attacking the defilade areas between buildings. Increasing the target altitude used in the FDS and FCS will allow the submunitions to achieve a more vertical fall prior to detonation and thus clear buildings and other obstructions (see Figure 4-6, page 4-29). Commanders must still consider the precision error and large submunitions dispersion patterns when applying this method of attack due to the high probability of extensive collateral damage. Low-level winds at the target area will add to the precision error. At longer ranges, large altitude adjustments may yield a "NO SOLUTION ERROR" in the launcher FCS.

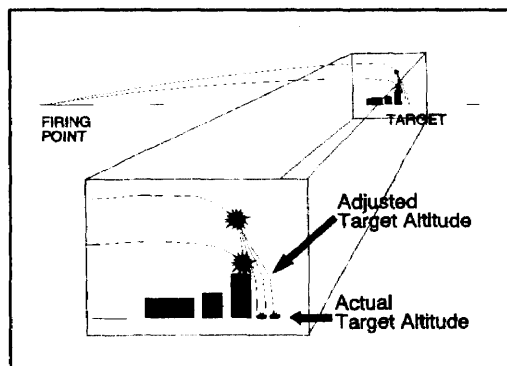

Figure 4-6. Urban targeting solution.

C2 of a firing platoon operating in an urban area is demanding. Decentralization to the maximum feasible extent may be required. The reduced ability to communicate necessitates more detailed orders and SOPs. The height and density of structures reduce the planning ranges for all organic radio equipment. Imaginative positioning of antennas for the platoon HQ, such as intermingling them with existing civilian antennas or in treetops, may increase transmission range and enhance survivability. Existing civilian communications networks may be used to supplement the organic capability of the unit.

MLRS units should not position launchers in built-up areas. Buildings can serve as concealment for hide areas, but the low trajectory of the system necessitates open areas for firing. Any urban area used for hide or CP positions should-

- Be free of civilians.
- Be away from the center of the built-up area.
- Have several routes of escape.
- Be off the main high-speed avenues.
- Afford as much cover and concealment as possible.

The use of existing structures (such as barns, auto repair shops, and warehouses) as hide areas or CP locations maximizes protection and minimizes the camouflage effort.

More time must be allotted for reconnaissance. Depending on the density of buildings in the area, the reconnaissance party may have to use infantry techniques

for house-to-house fighting to clear and check the buildings.

## Desert Operations

Deserts are arid, barren regions that cannot support any quantity of life because of lack of fresh water. They are characterized by temperature extremes (+136 °F in Libya or Mexico to bitter cold in the Gobi Desert) with fluctuations exceeding 70°. Fire support considerations vary according to the type of desert; however, considerations common to all include munitions effects due to the temperature extremes and a lack of identifiable terrain features. The three types of deserts are discussed below.

- The **mountain** desert is characterized by barren, rocky ranges separated by flat basins that may be studded by deep gullies created during flash floods.
- The **rocky plateau** desert has slight relief with extended flat areas and good visibility. It is characterized by steep-walled, eroded valleys (wadis). These are extremely attractive for concealment and limited cover but are subject to flash flooding.
- The **sandy** or **dune** desert has extensive flat areas covered with dunes subject to wind erosion. The dune size, the texture of sand, and the leeward gradient may prohibit terrain movement entirely.

Map reading is difficult and resections are impossible unless a number of prominent points are available. Position data from PADS, the launcher FCS, and the PLGR are critical.

Lack of vegetation makes camouflage difficult. In all cases, the MLRS unit is visible to the ground observer. From about 400 m in the air, the camouflaged command posts appear bigger than the surrounding dunes or mounds of sand and vegetation. Moving directly from position to position is not only feasible but often preferable using special formations (see *Tactical Marches* page 4-8).

High temperature and ever-present sand cause failures in mechanical and electronic equipment. Fuel and air filters must be cleaned after each operation, sometimes twice per day. Optics must be protected before the glass becomes opaque. Static electricity caused by the hot winds interferes with refueling operations and with radio traffic and launcher reload. Turning radii of tracked vehicles is



## FM 6-60

limited because of the buildup of sand between the idler wheel and the track.

### **Amphibious Assault**

Inherent in the concept of an amphibious assault is the projection of a fighting force into an area on shore that is assumed to be heavily defended. The force must be built in combat power from zero strength to a point where it is effective and credible. To provide adequate support, an MLRS unit must be prepared to fire immediately upon landing.

Although MLRS units are not intended to fulfill amphibious assault requirements, they may be required to conduct transit from ship-to-shore via landing craft. The MLRS equipment can be entered into the theater by air or sea, based on the priorities of the force or MAGTF commander. In those cases where the command authority directs positioning of MLRS equipment on Army prepositioned afloat (APA) or Maritime prepositioned forces (MPF) shipping, the force or MAGTF commander must consider the limitations of MLRS unit equipment with respect to each of the landing craft capabilities, since MLRS unit equipment is not currently "through-surf" capable.

**Landing Craft, Air Cushion (LCAC).** This preferable method of ship-to-shore transit for the MLRS unit allows

the launchers to disembark on dry land, affording maximum protection to MLRS system electronic components.

**Landing Craft, Utility (LCU) and Landing Craft, Mechanized (LCM-8).** The commander must consider that use of the LCU and LCM-8 will likely expose the launcher to partial immersion, potentially damaging components with salt water. However, these craft can be used for all ancillary wheeled vehicles.

Because of the small size of beachheads, positioning coordination with the supported maneuver force is critical. Units must remain flexible to change the predetermined positions on the basis of situation development at the beachhead.

Units must plan to embark and debark with all available MTOE equipment. Vehicles must be prepared for fording. Wheeled vehicle tires may be partially deflated for improved performance on beach sand. Saltwater and sand increase the need for preventive maintenance. Unit basic loads must be transported forward with the unit. An adequate ship-to-shore resupply of ammunition must be part of the plan and coordinated by the controlling FA headquarters (Div Arty, Marine Arty Regt, etc.) S4.

## CHAPTER 5

## DELIVERY OF FIRES

**Delivering MLRS fires and achieving the desired effects on target is a multistep, multichannel operation. It involves thorough and effective fire planning. The versatility of the MLRS FCS, FDS, and IFSAS/TACFIRE allows smooth, rapid, and accurate fire planning, target processing, and target engagement. The unique characteristics of this fire delivery process must be understood for maximum effective use. (A sample firing safety checklist is provided in Appendix J.)**

---

Section I  
INTRODUCTION

---

### Organization and Structure

#### General

Organizations supported by MLRS units normally include division, corps and echelons above corps (EAC) and/or JTF. A number of fire support planning and execution agencies support the targeting process for MLRS units, especially those employed with Army TACMS. These agencies include:

- The FSE and deep operations coordination cell (DOCC).
- National/joint service target acquisition sensors and processing facilities.
- Intelligence collection, analysis, and dissemination nodes of the all-source analysis system/analysis control element (ASAS/ACE).

#### Systems

It is essential that requests for use of Army TACMS be entered as expeditiously as possible into the FS system. This is necessary due to extensive airspace and deep targeting coordination and planning needs. This is done manually, or in a semiautomatic mode using a variety of systems. This includes:

- Automated deep operations coordination system (ADOCS), light TACFIRE, TACFIRE/IFSAS.
- The FDDM.
- The MLRS FDS, or the IFSAS, FDDM.

This process will ultimately become fully automated using Army Battle Command System Common Hardware and Software.

### Structure

The command and control requirements for MLRS units are centered around a fire support structure that supports the scheme of fire and maneuver. This structure includes acquisition, C2, and fire control systems from sensor system through the delivery system. An example of the hierarchical structure is illustrated in Figure 5-1, page 5-2.

#### Control

**Rockets.** Rockets will normally be fired at targets within the division's area of operations by the organic divisional MLRS battery, an attached MLRS battalion, or a R FA brigade. These units supporting the division are normally under the control of the div arty with input from the division FSE.

**Missile.** Army TACMS variants will normally be fired at targets beyond the division's area of operations by the organic corps MLRS battalion(s).

The key to effective employment of Army TACMS is planning and coordination (prior to execution). The planning tasks and functions necessary for the employment of Army TACMS will be managed under centralized control normally at corps or EAC. Execution functions for fixed or non mobile targets may also be initiated under centralized control. Responsiveness may be improved by tailoring linkages to allow shorter paths (decentralized execution) from target acquisition sources through FA brigade or MLRS battalion nodes to the launcher, for the attack of fleeting targets. If the force commander desires to decentralize execution for certain targets (typically high priority fleeting targets which are vulnerable to attack for very short periods of time) he will normally designate a subordinate commander (unit) as the execution authority.

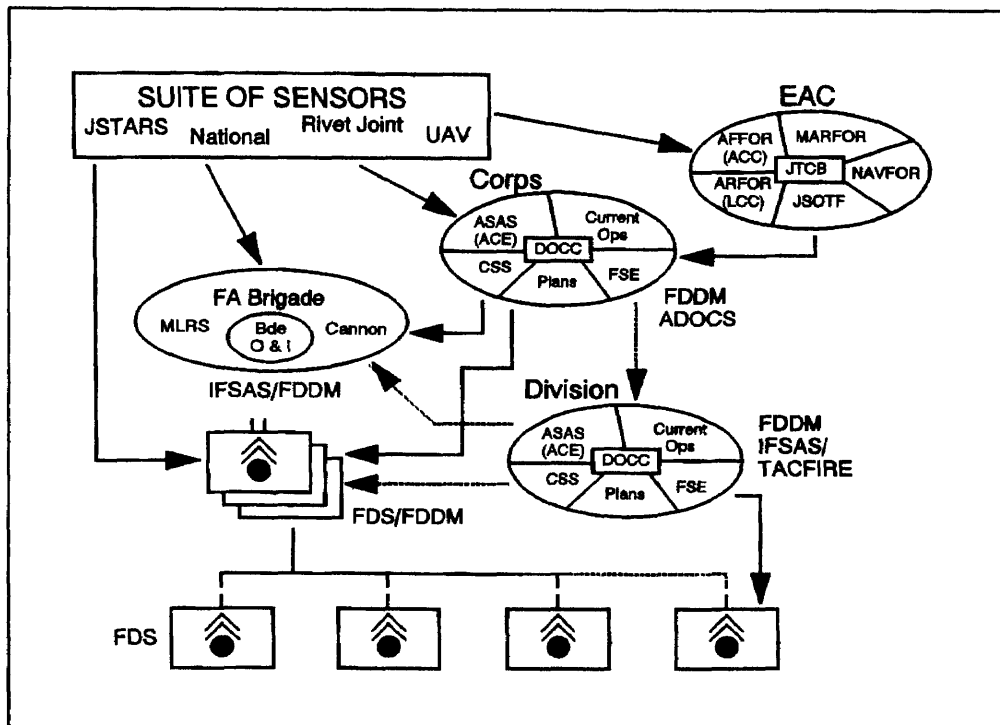

Figure 5-1. Delivery of fires structure.

**Echelons**

The FDDM performs corps FSE, FA brigade, MLRS battalion, or MLRS battery functions depending on operator inputs. The FDS performs only MLRS battalion, battery or platoon functions. There is no significant degradation of functionality for battalions or batteries fielded with the FDS with the current munitions. All fire planning and FDC personnel work with different functions of the system appropriate to the assigned echelon. Thus, personnel can be easily transferred between MLRS unit echelons with little additional training. The general operational organization is as follows:

**Corps FSE computer (FDDM):**

- Acts as the primary fire planning agency for Army TACMS. (Army TACMS SPAP will be loaded in this FDDM only. Loading in subordinate systems will significantly add to mission processing time.)
- Determines target values and priorities.
- Determines commander’s criteria for effects.
- Checks for fire support coordinating measure (FSCM) violations.

**FA Brigade computer (IFSAS):**

- Performs fire planning function.
- Checks for FSCM violations.
- Performs tactical fire control.
- Sets ammo expenditure and supply limits.

**Battalion computer (FDS/FDDM):**

- Checks for FSCM violations.
- Distributes fire missions based on platoon positions.
- Assists batteries in coordination of positions.
- Distributes and disseminates fire plans (target lists) to batteries.

**Battery computer (FDS):**

- Performs effects processing based on commander’s criteria.
- Checks for FSCM violations.
- Assigns missions to launchers based on current status.
- Distributes fire plans.
- Maintains status of launchers.

---

Section II  
MLRS FIRE DIRECTION CENTERS

---

### Battalion Level

The battalion FDC tactically controls the fires of the battalion with the FDS/FDDM. The battalion FDC is the NCS for the Fire Direction (FD) Net(s) and the primary link with the force FA headquarters for all delivery of fires by the MLRS battalion. (Battalion FDC personnel are listed in Table 5-1.)

**Table 5-1. Battalion FDC Personnel.**

Position	Rank	MOS
BN FDO	CPT	13A00
Chief, Fire Direction Computer	SFC	13P40
Fire Direction Computer	SSG	13P30
Battery Display Operator (2)	SGT	13P20
Fire Direction Specialist (3)	SPC	13P10

Selection of targets for the MLRS battalion is the responsibility of the controlling FA headquarters or FSE. Fire plans are sent to a battalion as target lists with specific implementing instructions (e.g., H-hour and times, relative to H-hour in a series). The battalion selects batteries to execute the fire missions and then transmits the targets or the complete plans to them. Targets that fall in the category of unscheduled fires are distributed on the basis of battery or platoon status (range to target, number of missions in progress, launcher availability, and ammo type and status).

### Battery Level

The MLRS battery is concerned solely with the delivery of fires. The battery engages targets in one of two modes--scheduled or unscheduled fires. These modes determine the way the FDS processes missions.

The battery FDS uses the methods of control below:

- **ONC (On Call).** Must be changed to another method before execution.

- **WR (When Ready).**
- **AMC (At My Command).**
- **TOT (Time On Target).** Uses a time for effects on target.
- **TTF (Time To Fire).** Uses a specific launch time.

The launcher FCS uses the methods of control below:

- **ONC.** Must be changed to another method before execution.
- **FWR (Fire When Ready).**
- **AMC.**
- **TOT.**
- **TTF.**
- **TTT (Timed Time On Target).** Uses a time window for effects or target. (TOT with a NLT entered in the FDS).
- **TWR (Timed When Ready).** Uses a time window for launch (WR with a NLT entered in the FDS).

**Note: The TTT and TWR methods use time windows. These windows must be less than 60 minutes. TTT and TWR methods allow the firing launchers more flexibility than the TTF or TOT methods.**

The FDS usually performs the fire direction tasks automatically. Battery FDC personnel are listed in Table 5-2, page 5-4. Responsibilities include the following:

- Target analysis and selection of type and number of rockets and/or missiles to fire.
- Selects number and dispersion of aimpoints.
- Downrange mask checks.
- Fire support coordinating measures and air corridor checks.

## FM 6-60

- Selection of platoon and launcher to respond.
- Transmission of fire orders.
- Recording the missions.

**Table 5-2. Battery FDC Personnel**

Position	Rank	MOS
Fire Direction <sup>1</sup> Computer	SSG <sup>1</sup>	13P30 <sup>1</sup>
Battery Display Operator	SGT	13P20
Fire Direction Specialist (5)	SPC	13P10

**Note:** <sup>1</sup>Chief FD computer, SFC, 13P40 in divisional batteries.

## Platoon Level

The FDS enables the platoon to command and control of platoon assets and, if necessary, to assume control of battery functions. Platoon FDC personnel are listed in Table 5-3.

**Table 5-3. Platoon FDC Personnel**

Position	Rank	MOS
Battery Display Operator	SGT	13P20
FD Specialist (2)	SPC	13P10

---

### Section III MISSION PROCESSING

---

#### General

Fire mission source is not particularly important to the tactical conduct of the fire mission execution process for automated processing of missions. It does have some significance in terms of estimates of normal expected target location error for munition selection and effects calculation. What is important to the outcome of the automated processes is target type, the point of entry into the munition and fire unit selection process (node/system), linkage to the shooter, method of control and whether or not a munition has been specified.

The corps and MLRS FDS/FDDMs perform tactical fire direction based on the MLRS platoon centers reported by the battery. Generally, the battery is the highest echelon tracking individual launcher status. Launcher status reports are consolidated into platoon aggregates and reported to the battalion and subsequently the corps according to a predetermined time table. Since the corps FDDM generally has the least current information concerning launcher status, it is possible that missions may be assigned to platoons which cannot comply. This should be reported as soon as possible, since airspace coordination may require adjustment if alternative units are selected to fire the missions. The coordination is normally conducted at the corps or JTF level.

Once the FDO determines the exact unit to fire, the mission(s) is transmitted to the designated battery. The battery then transmits the mission(s) to the designated launcher(s) when the time to fire becomes 30 minutes or less. The launcher(s) will receive the missions, compute the technical solution and fire the missions(s) based on the method of control specified in the mission.

Extremely time sensitive targets designated for attack using Army TACMS may necessitate placing the launcher on the firing point to shorten the response time. This may be accomplished using a posture message (AFU;POSTURE to battery and MLRS;CMD to launcher), or by transmitting an AMC mission to the launcher. This technique will cause the launcher to complete the mission sequence up to the point of achieving aimpoint, and then report ready status. Upon receipt of an amended fire mission changing the method of control to FWR (or TTF or TOT), the launcher will complete the mission as directed.

Fire mission processing at MLRS battalion and battery FDCs treats all munitions in the same manner. As a minimum, an AFU; AMODAT message must be received and executed so that the software can recognize the munition J-Code in the CFF message. If effects processing is desired, entry of carrier delivery errors and effects (AFU;EFFDAT and SPRT;RNGEFF) data are

required; otherwise, only volleys missions will be processed. There is no default in the FDS software for the number of Army TACMS missiles to be fired on a given aimpoint. When the fire mission (FM;CFF) is received at the battalion, the FDC will perform the tactical processing and (if applicable) effects processing. It will then format another FM;CFF for transmission to the battery; the battalion FDC will select the platoon to fire if it has not been selected, otherwise it will validate the BCD IFSAS selection.

At the battery level, the FDC will perform the tactical functions appropriate to the battery echelon, select the launcher or launchers to fire and generate a separate MLRS;CFF to each selected launcher.

Technical fire direction occurs at the M270 launcher. The appropriate weapon's application software and ballistics data must be resident on the launcher in order to successfully fire a specific munition. (See Appendix K for ballistic algorithm tables.)

### Launcher Status Management

The battery FDC computer maintains the status for each assigned launcher. As a minimum, the battery maintains the following conditions and states:

- Activity

- Single busy (one fire mission assigned and active)
- Double busy (two missions assigned and active)
- Priority busy (one or two highest priority missions)
- Not busy
- Not moving

- Launcher operational status (OPER/INOP)
  - Reason
  - Duration
- Location information
- Ammunition status and availability

### Fire Mission Execution Function

This section addresses the top level concepts of fire mission execution. This complicated process is deeply integrated with other FDC computer functions. The computer executes fire missions by establishing and updating relevant information. This function is graphically depicted in Figure 5-2.

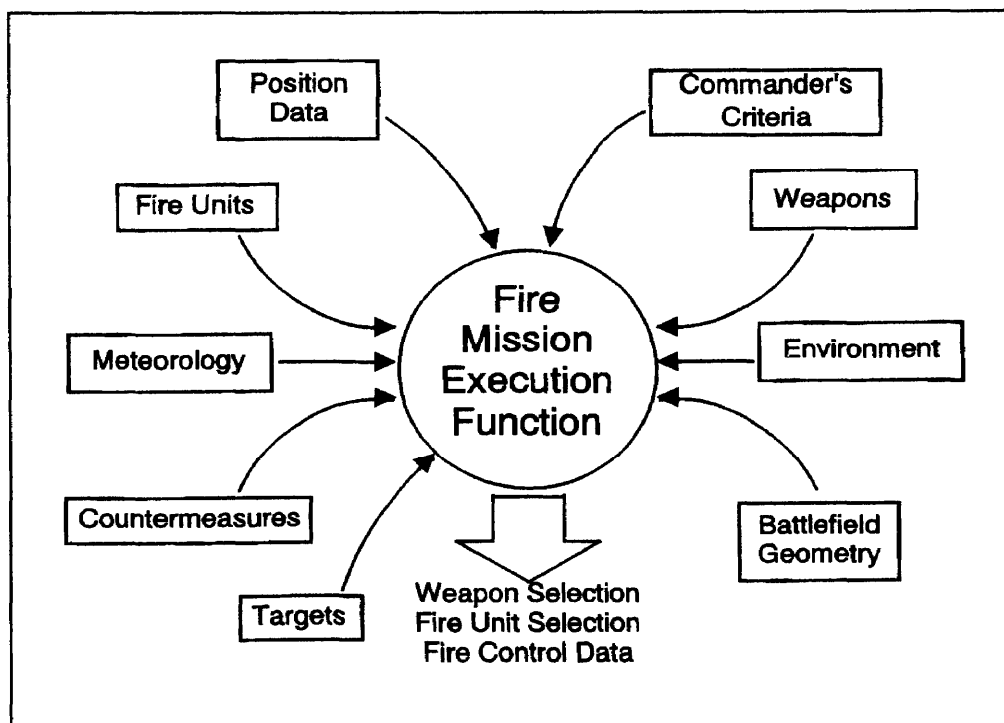

Figure 5-2. Fire mission execution.

## FM 6-60

### Target Analysis

Upon receipt of a fire mission message, the computer screens the target to determine the requirements for target analysis. The computer analyzes the target using the information below to determine its placement in the commander's criteria and to specified priority or non priority handling.

- Type/subtype/element
- Location
- Strength
- Behavior
- Permanence and age

A preliminary munitions list is developed and presented to the operator for a decision and for further processing after target and weapon analysis (FDDM only).

### Weapon (Munition/Submunition) Selection

Targets/missions that are received from a higher echelon's computer that specify a weapon to be employed are evaluated. The subordinate unit has the capability to change the type of weapon employed against a target. Although subordinate FDCs have the capability to change the weapon type, authorization to modify missions directed by a higher echelon computer must be coordinated. If the FDC is authorized to change the weapon directed, it must be done manually.

### Battlefield Geometry Validation

The FDC computer validates that the fire mission does not violate any FSCM or down range (DR) mask restrictions. FSCM violations will be presented to the operator in the form of a WARNING message, but can continue to process the fire mission. DR mask violations will be presented in the form of any error message and will prevent the operator from continuing the mission.

### Fire Unit Selection

Fire unit selection in the FDC computer is based on the following:

- Availability--No more than the allowable number of fire missions at each launcher.

- Appropriate munitions onboard or at next reload point.
- Within range of selected munitions.
- No exclusions.
- Able to meet all time restrictions.

### Target Processing

**Volleys-Type Target.** If the target is designated as a volleys type, all rockets are normally aimed at the center of the target unless the of size or shape are large and specified. If the number of rockets to be fired at the one aimpoint is entered in the volleys field of the message, that number of rockets is fired at the target's center. If there is no entry, a default value of six rockets is used.

**Effects-Type Target.** If the target is designated as an effects-type target, the FDS may generate multiple aimpoints. The computer performs effects calculations and determines the expected effects for each target selected for engagement based on weapon performance, capability characteristics, and target degree of protection.

- The target type is checked to be sure it is a legal effects type. If it is not, a warning message is displayed.
- The target dimensions are checked to verify that they are within the size limits for MLRS processing. If they are not, the computer stops processing, the mission is rejected, and is redisplayed for transmission back to the higher headquarters.
- The computer designates one to six aimpoints for an effects target. The number of aimpoints for an effects-type target and the number of rockets to be fired at each aimpoint depends on the following:
  - Desired effects (for effects- type target only).
  - Dimensions of the target.
  - Range to target from the launcher.
  - Lethal area of submunition in relation to target type.
  - Disposition of enemy personnel in the target area.

- The computer rejects the fire mission request when--
  - Percentage of effects requested cannot be achieved.
  - Solution indicates that more than maximum number of rounds to fire (for an effects-type target only).
- The number of aimpoints, aimpoint casting and northing offset from target center, and number of rockets required for each aimpoint are stored, temporarily, for use by the fire unit selection routing.

mathematical modeling. Using JMEMs to determine attack data requires considerable time. Because of time constraints, use of JMEMs at battalion and battery FDC levels for engaging targets of opportunity is not recommended. The effects data included in these manuals incorporate reliability, delivery accuracy, and munitions lethality against a representative spectrum of targets. The computational assumptions, defeat criteria, and instructions for use are included in each manual.

**Note:** There is no assurance that the expected fraction of damage or casualties will be provided by any number of volleys in a given situation. Although not precisely within the mathematical definition, the method of averaging data used for the tables will result in less damage being realized for approximately 50 percent of the rounds and, conversely, greater damage for the other 50 percent of the rounds.

### Joint Munitions Effectiveness Manuals

Effectiveness tables published in joint munitions effectiveness manuals for surface-to-surface weapons (JMEM/SS) provide guidance for determining the expected fraction of casualties to personnel targets or damage to materiel targets. The JMEMs for surface-to-surface weapons are published as field manuals. The manuals currently available for all systems are listed in FM 6-141-1. The basic data for these manuals were obtained from test firings, actual combat performance, and

### Fire Mission Support Function

The fire mission support function establishes or updates the map mod, geometry, ammunition effects, and meteorological databases to enhance tactical fire control. This function is depicted in Figure 5-3.

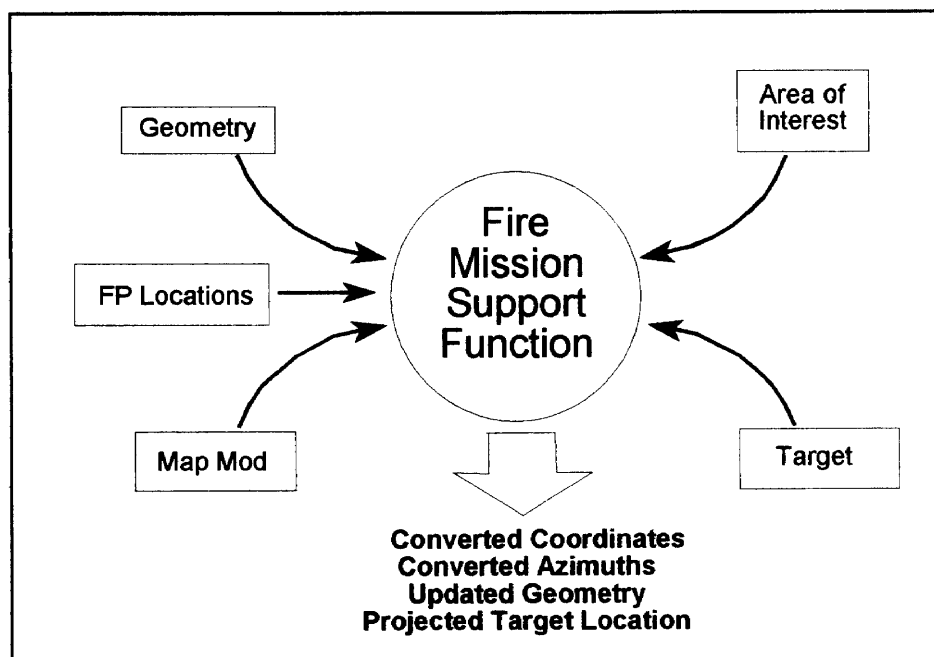

Figure 5-3. Fire mission support function.



## FM 6-60

The basic functions are:

### Coordinate Conversion

- Zone to zone transformation.
- Zone to zone across grid zones.
- Spheroid conversion.
- Datum conversion.
- Geodetic/UTM.

### Battlefield Geometry Maintenance

- Overwrites duplicate geometry features.
- Reports overlap of SPRT;ZNE messages.

### Fire Support Scheduling Function

The planning and scheduling function of the FDDM computer are designed to provide the artillery commander, and to a lesser extent the FSE, tools to perform resource prediction, posturing, and accounting by event or time table. The fire mission schedule processing function establishes and updates fire mission schedule information, determines the number of fire unit assets eligible for scheduling, removes scheduled fire missions and fire unit assets, and generates the appropriate information messages for transmission to other FDC computers. The

FDDM scheduler function accepts fire missions if the TOT and/or TTF specified in the original fire mission message is greater than 40 minutes but less than 96 hours from system time. Missions falling within the 40 minute window for engagement will be transmitted to the firing unit, to be engaged in accordance with the method of control associated with the mission. Figure 5-4 portrays the scheduling function.

The fire planning function for both FDS and FDDM accepts a maximum of 75 fire plan targets. The TOT and/or TTF specified in the message should be greater than 30 minutes but less than 24 hours from system time. A time of less than 30 minutes may preclude the FDS/FDDM from automatically retrieving the fire plan from the database for execution. A time greater than 24 hours will cause the computer to subtract 24 hours from the specified times (the system is on one 24 hour clock).

### Fire Plans and Schedules

Fire plans and schedules of fires will be processed upon receipt. When the timetable for execution is known and within scope, allocations of available ammunition and fire units will be made for the fire plan or scheduled targets. FDCs should know that this does not prevent execution of other missions using this allocated ammunition. If execution of all targets is not possible, an exception report will be prepared and presented for operator action and adjudication.

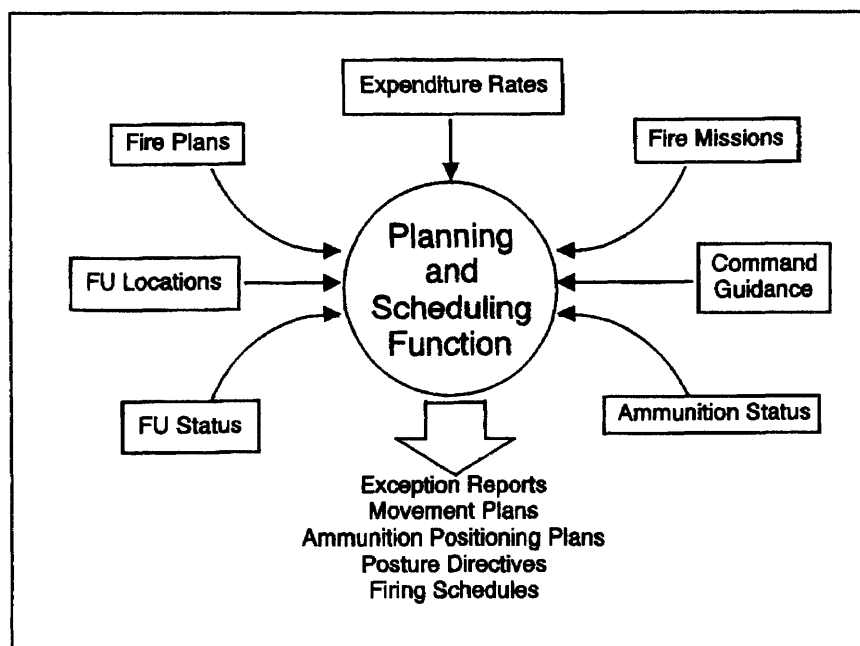

Figure 5-4. Fire planning and scheduling.

### Resource Scheduling

Resource scheduling is the process of pre-allocating fire unit and ammunition resources to expected mission loads in advance of execution time. This should occur as soon as projection of friendly and enemy courses of action and expected resource demands by time period can be made, so that battalion and battery level posturing and ammunition loading can be accomplished. Development of alternate courses of action and supporting plans typically occurs from 72-96 hours in advance of the intended operation. Consequently, this function provides scheduling of resources no earlier than 96 hours prior to execution. Expected mission loads exceeding anticipated available resources, are reported to the operator for exception resolution. As a minimum, the operator must report exceptions relating to ammunition type, ammunition quantity, and fire unit sufficiency (i.e. "are there enough launchers?") by specifying the time period for which resources are unavailable or insufficient (e.g. "2/A/3/9 FA down for maintenance 0600-0700," or "there are insufficient launchers available to properly cover target #AA0001 during time period X"). The fire planner then accounts for resources which are unavailable for whatever reason. Fire missions to be included in this analysis are TOT, TTF (and TWR/TTT), or other scheduled targets. AMC and WR mission firing times are undefined and consequently will not influence the analysis except by their impact on current resources.

### Ammunition Positioning Planning

Ammunition positioning is closely related to the AFU functions and resource posturing. When performed properly, it involves the use of fire plans and schedules, resource scheduling, and contingency planning outputs

combined with expected usage rates. (Further discussion on Ammunition Posturing is in Chapter 4.)

### Fire Mission Cycle

The BOC processes fire missions for the MLRS firing battery. Mission assignments are based on the following information:

- Grid locations of FPs.
- Requested FP and RL employment sequence.
- Number and type of rockets or missiles currently on board each launcher and on HEMTT-HEMATs in the platoon OPAREA.
- Down Range Mask.
- Launcher status and locations.
- FSCMs.

These are all part of the FDS database for the battery. The FDS then selects the launcher to respond, the number and type of munitions to fire, number and dispersion of aim points, and the method of fire. The fire mission is then passed directly to the launcher. Using the platoon FDS, the POC monitors the fire missions. If the launcher cannot communicate digitally with the BOC, the platoon FDS can be used to relay fire missions. At a minimum, both the BOC and POC record the mission by using DA Form 7232-R (see the example below, Figure 5-5) and plot the target on the firing capabilities map. The completed DA Form 7232-R should be retained for one year.

MLRS FDC FIRE MISSION LOG										DATE	UNIT	
For use of this form, see FM 6-60. The proponent agency is TRADOC.										30 MAR 92	2/A/4/27/FA	
TARGET NUMBER (a)	TARGET EASTING (b)	TARGET NORTHING (c)	UNIT ASSIGNED (d)	TIME OF RECEIPT (e)	NUMBER OF ROUNDS TO FIRE (f)	AMMO TYPE TO FIRE (g)	METHOD OF CONTROL TOT TIME (h)	TIME WHEN SENT (i)	MISSION STATUS (j)	TIME MFR RECEIVED (k)	NUMBER OF ROUNDS FIRED (l)	REMARKS (m)
XA 0011	6812	1624	1-1-A	2330	12	JED	AMC	2331	READY	2332	12	EOM
XA 0013	6747	1581	<del>1-3-A</del> 2-3-A	2335	15	JED	2350	2334	READY	2335	15	EOM 1-3-A & 2-3-A
XA 0016	6688	1589	2-1-A	2336	<del>8</del> 5	JED	WR	2336	READY	2336	8	EOM
XA 0018	6751	1499	1-2-A	2340	6	JED	WR	2340	CANCOM	2341	0	EOM Ammo Prob-FP AB
XA 0018	6751	1499	3-2-A	2341	6	JED	WR	2342	READY	2342	6	EOM Reassigned from 1-2-A
							31	MAR	92			
XA 0001	6915	1833	2-1-A	0015	2	JEE	0030	0016	READY	0016	2	EOM

Figure 5-5. DA Form 7232-R.

## FM 6-60

Upon receipt of a fire mission, the launcher FCS conducts a consistency check of the fire mission data to ensure that the launcher can fire the mission, that it has the correct munitions loaded, and that the target is in range. If it can fire, a will comply (WILCO) message is generated to be sent to the battery FDS.

The section chief should have previously inspected the FP for any immediate mask (within 2000 m). If one is apparent, he measures the mask with the M2 compass to determine if it should be entered in the FCS. The mask should be entered if it measures 100 mils or greater. If the launcher cannot fire over the mask, it must be repositioned.

If an immediate mask is not a problem, the launcher then moves to the designated FP and orients on the selected parking heading. The crew lays the LLM, arms the system, fires the mission(s), stows the LLM, and moves as directed. The launcher crew records the mission data by using DA Form 7233-R (MLRS Launcher Fire Mission Log) as shown in the example, Figure 5-6, below. A reproducible copy of DA Form 7233-R is at the back of this manual. The completed form should also be retained for one year.

### Commander's Criteria

The commander influences IFSAS/TACFIRE tactical fire control (TFC) solutions by establishing his commander's intent, which is used to develop the commander's criteria for engaging targets. These criteria guide the selection of units to fire, munitions, and volume of fire for each mission. The IFSAS, based on a portion of the Commander's criteria, selects targets for MLRS engagement. It helps in the fire planning, collation of intelligence, and TFC for MLRS. The commander's

criteria should be entered into IFSAS/TACFIRE before the fight begins. When they have been entered, the computer will automatically execute the criteria without delaying fire mission processing.

Commander's criteria are established, and updated as the situation changes. They may be overridden manually whenever a situation warrants. As circumstances and SOP dictate, the battalion operations officer, battery operations officer, and/or fire direction personnel can override the commander's modifications on a mission-to-mission basis. A specific request for fire overrides the commander's criteria. Extreme care must be used in modifying the execution of the commander's criteria, since their effect on the IFSAS/TACFIRE and FDS solutions influences the outcome of the battle. The parameters involved in establishing the commander's criteria are discussed below.

The supported maneuver commander's intent is used to develop engagement criteria. When given an R mission, the MLRS unit will use the criteria of the reinforced unit's supported maneuver force. When assigned a GSR or GS mission, the MLRS unit will use the criteria of the force headquarters.

### Commander's Criteria Modification File

The commander's modification file consists of multiple segments listed below, however, only the maximum rockets (MAXRKTS) and the effects cutoff factor (ECOF) can be directly influenced at the FDS. All other files are modified at the servicing IFSAS/TACFIRE.

### Ignore Ammunition

The IGAMMO (ignore ammunition) modification directs the computer to select units to fire regardless of the

MLRS LAUNCHER FIRE MISSION LOG <small>For use of this form, see FM 6-60. The reporting agency is TRADOC.</small>				DATE <b>16 MAR 96</b>			SECTION CHIEF <b>SSE JONES</b>		UNIT/SECTION <b>2/3/A/92 FA</b>	
TARGET NUMBER (a)	TARGET COORDINATES (b)	FIRING POINT (c)	METHOD OF CONTROL (d)	FIRING DATA			AMMUNITION			TIME OF FIRST FIRE (h)
				AZIMUTH (e)	ELEV (f)	FZ TIME (g)	TYPE (DDIC) (i)	NUMBER OF ROUNDS ASSIGNED (j)	FIRED (k)	
AB 0001	5365 7046	4092 6352	FWR	0901.6	234.7	28.3	H104	06	06	09:13:26
AB 0003	5401 6835	4075 5842	TOT	1023.6	217.9	25.9	H104	06	06	11:23:27
AC 0010	5225 6521	4110 6000	FWR	0789.4	973.0	N/A	PLB1	02	01	13:40:20
AC 0011	5225 6396	3995 5765	TWR	1757.6	973.0	N/A	PLB1	02	02	16:50:17
AB 0012	5325 5842	4110 5845	ON CALL	2152.4	973.0	N/A	PLB1	01	01	19:13:02
<b>17 MAR 96</b>										
AD 0001	5210 6925	3895 6170	FWR	6319.6	751.9	86.3	H104	07	00	N/A

Figure 5-6. DA Form 7233-R.

ammunition on hand. This keeps a fire unit from being excluded solely on the basis of not having the required ammunition. When IGAMMO is in effect, the controlled supply rates are violated, since all ammo constraints are ignored. Fire planners use IGAMMO in the fire planning modifications when planning future fires to determine ammo requirements. Usually, IGAMMO is not used for current TFC operations.

**Maximum Rockets**

The commander can limit the number of volleys that a fire unit or weapon type may fire against a single target or target type. MAXRKTS is specified for each weapon type and applies to each fire unit with that weapon. The lower the MAXRKTS, the more fire units the computer must select to achieve the required volleys or desired effects on a target. If not specified for a particular weapon type, MAXRKTS defaults to six rockets.

**Fire Unit Selection**

The commander can assign an ordering number for each battalion and each fire unit within a battalion. He must be careful when ordering fire units, because the one ordered first will always be chosen before others. Therefore, it is recommended that all units be ordered equally. Fire units can then be selected on the basis of busy status, frequency of assignment, and the order entered into the ammunition and fire unit (AFU) file.

**Exclusions**

A commander can exclude fire units, weapon types, shells, or fuzes from consideration during TFC. The MLRS FDS can exclude a fire unit for a specific fire plan only.

**Attack Methods**

The attack methods table in the computer defaults to a desired effects value of 10 percent for M77 DPICM effects-type targets, except ARTY/POS and personnel type targets within a degree of protection (DOP) of PRONE, PRAND, and DUGIN, which all default to 30%. Default value for Army TACMS is 30 percent. An MLRS standard volleys factor (SVF) of six is the default for all volleys targets. The commander can override the attack criteria for each target type and can specify an SVF for an effects target. However, he cannot specify desired effects for a volleys target. For a volleys target, the SVF works with the volleys size factor (VSF) to generate the

computer recommendation for the total number of volleys to fire on the target. The FDS or IFSAS/TACFIRE operator can override attack criteria by assigning the number of volleys to fire on the target on a mission-to-mission basis for either effects or volleys targets. Effects processing for MLRS targets is performed by battalion, battery, and platoon FDS--not by IFSAS.

**Munition Selection Matrix**

Table 5-4 gives the fire planner a matrix for determining the best MLRS munition with which to defeat a target.

**Table 5-4. Munition Selection Matrix**

MUNITION	CHARACTERISTICS	TARGETS
M26 Rocket	M77 DPICM 644 Bomblets Per Rocket	Personnel, Light Armor, and Soft Vehicles
M39 Missile	M74 APAM 950 Bomblets Per Missile	Personnel and/or Light Materiel

**Effects Cutoff Factor**

The ECOF is a value that limits the ammo expenditures on effects targets. It specifies the minimum percentage of effects that the commander considers acceptable on a Fire Mission. The ECOF is always entered into the computer in tenths of 1 percent. For example, an entry of 20 specifies an ECOF of 2.0 percent. The above information applies to both TACFIRE, IFSAS, and the MLRS FDS/FDDM; however, each computer processes ECOF in a different way. The MLRS ECOF processing procedures are discussed in the next two paragraphs.

The MLRS FDS begins effects processing with one round specified for the target. Then it adds one round at a time, comparing the effects of the second and subsequent rounds to the ECOF to ensure the ECOF has been achieved. The computer stops processing effects when an increase of one round fired on the target does not provide an increase in effects equal to or greater than the ECOF value. The comparison starts with the first round added, or the second round. It is, therefore, possible to receive a computer solution of one round to be fired on an effects target. This is enough for personnel in the open, but it certainly would be ineffective on an armored target. The ECOF may be

changed as the situation changes. However, in general, for hard targets, the MLRS ECOF should not be greater than 0.5 percent; 0.2 percent is preferred. This gives the commander more flexibility in employing his MLRS fires. If ammo availability becomes a problem, the commander can decrease the ECOF, restrict the use of MLRS to certain target types, specific all MLRS targets be treated as volleys targets, or do any combination of the above.

The ECOF is part of the MLRS setup process. The initial MLRS ECOF is included in the OPORD. Subsequent changes to the ECOF can be sent to the MLRS unit by courier or by secure radio (voice or data).

### **MLRS Size**

If the TACFIRE/IFSAS AFU file contains MLRS fire units, the computer considers those units first to engage a target when the target radius exceeds the size entered in the MLRSIZ (MLRS size) modification.

### **Target Criteria**

Another consideration for assigning targets to MLRS units is the possibility of TACFIRE/IFSAS or the FDS rejecting the target because of size or target type. It is very important that commanders and, in particular, FSE personnel and TACFIRE/IFSAS operators be thoroughly familiar with MLRS target criteria.

### **MLRS Fire Plan Processing**

Current IFSAS and LTACFIRE software can perform effects processing for all MLRS munitions. For munitions other than M77 DPICM, IFSAS (and FDS) must have the supporting weapon's descriptor file in the data base to calculate effects.

On-call schedules for MLRS support should be requested no less than 30 minutes before desired fire support. This rule is based on the reaction time required by the MLRS FDS and the average fire mission cycle of 20 to 30 minutes. Included are receiving the fire mission, reloading, and moving to the firing point or hide area.

Depending on the time between missions in a single fire plan, launchers can fire, reload, and fire again. (From 20 to 45 minutes maybe required for a launcher to reload and be ready for another mission.) Depending on the number of rockets required for each mission, launchers can fire one mission, move to another FP, and fire again. In the case of a rapid fire plan and large fire volumes, no single launcher should be given more than one target per fire plan, for a maximum of nine targets per battery. When the

situation warrants, batteries can be given up to three targets per launcher. (This factor is based on the launcher capability to store three missions. Any number of targets over 27 would require processing by the FDS during the execution portion of the fire plan.) However, firing multiple missions from a single launcher during a rapid schedule may require launchers to remain on the same FP for an extended time. During this exposure, launchers become extremely vulnerable to counterfire.

The total rockets in the plan should not exceed 72 (6 launchers x 12 rockets each) and cannot exceed 108 (9 launchers x 12 rockets each). The number of rockets per target depends on target size and type. Schedules of fire must be coordinated with the operations officer so he can manage launcher posture and/or response time. The fire planner must have an accurate picture of launcher status. Because of maintenance, personnel, and other factors, a "rule of thumb" is to plan fires for no more than six launchers at one time. If a surge condition arises, the unit can be tasked to provide a higher number. If all available launchers fire on a schedule, temporary loss of a FS asset (20 to 45 minutes) can be expected while the launchers move to reload points, reload, and return to firing points.

In anticipation of future operations, the FSE can transmit posture information (see page 5-4), directing the munitions to be available within a specified time frame. This posture information can be stored in the data base at battalion, battery, and platoon.

### **Reacting to Fire Plan Changes**

The NNFP function, for all IFSAS-based systems, does not lend itself to change. If last minute changes are anticipated to planned targets, then the FDC has several options based on anticipated reaction time to changes (see Table 5-5).

### **Resource Limitations**

If the numbers of targets are excessive or the available launchers are limited, units can take advantage of the multiple fire mission sequence capability. The multiple fire mission sequence allows the launcher to fire two or more missions without stowing the launcher. If a battery, for instance, received eight targets to engage, it may commit less than eight launchers. Initiating the multiple fire mission sequence requires the assignment of two targets to the same firing point identifier. When this occurs, the FCS recognizes it as a multiple fire mission. If the method of fire control is FWR, the launcher will automatically lay on and fire the second target without a

second SAFE, ARM or FIRE command. If another method of fire control is specified for the second target, the FCS will lay on the second target, then prompt the

crew to SAFE the rockets. The FCS will then prompt the crew to ARM and FIRE IAW the specified method of control.

**Table 5-5. Fire Plan Change Reaction Times.**

ANTICIPATED REACTION TIME	METHOD
30 MINUTES	Use the NNFP function and assign H-hour.
20-30 MINUTES	Use the NNFP function. Do not assign H-hour. Once the actual H-hour is identified, enter it and process.
10-20 MINUTES	Transmit each of the targets as AMC missions to the launchers. This requires them to move to the firing point and lay on the target. Once the TOT time is known, transmit an amended call-for-fire (CFF).
5-10 MINUTES	Transmit each of the targets as AMC missions to the launchers. "Back-off" the highest time of flight and coordinate trigger points with the aviation unit (through the appropriate FSE). When the aviators cross the trigger point, the FSE sends the fire message.

## CHAPTER 6

**COMBAT SERVICE SUPPORT**

**Combat service support (CSS) includes those functions and services required to man, arm, fuel, fix, move, and sustain forces in combat operations. The division support command (DISCOM) and corps support command (COSCOM) are organized to provide the full range of health services and personnel functions as well as the traditional logistics functions of supply, maintenance, field services, and transportation. This chapter covers all functional areas of CSS.**

---

Section I  
**ORGANIZATION**

---

**Logistics**

Commanders and leaders at all echelons are responsible for the CSS of organic and attached elements in their commands. Each leader anticipates his requirements, makes his needs known, and uses the available CSS elements.

CSS must constantly be pushed forward to using units, giving them the means to complete their missions. At all echelons, CSS activities must be located close enough to the supported unit for expedient resupply by the support unit organic transportation assets. Divisional MLRS units receive support from the DISCOM MSB, whereas corps units are supported by COSCOM. Corps MLRS units are supported by forward corps support battalions (FCSB) normally located in the division support area (DSA). The composition of a FCSB depends on the assigned mission, units requiring support and duration of support.

The logistics plan, based on adequate and timely support of the tactical operation, must be complete, simple, and flexible. It must facilitate future operations and be coordinated with all appropriate support agencies. Combat service support and tactical planning are interwoven. Battalion-level units stock some combat-essential supplies such as rations and repair parts (called prescribed loads) and conventional ammunition (called basic loads). These stocks enable units to continue operating if the supply chain is temporarily broken or if it is not yet operational within the zone of operations. Basic loads are those supplies kept by units for use in combat (for other than ammunition). The quantity of each item of supply in a basic load is related to the number of days in combat the units may be sustained without resupply.

**Logistics Support Areas**

Combat service support to units organic or attached to the division is provided by the MSB, located in the DSA. The DSA also contains the division trains and forward COSCOM elements operating in the division sector. The MSB commander controls all DISCOM and COSCOM elements operating in the DSA. The MSB provides support to the division as a whole, attached MLRS battalions, and to the divisional MLRS battery. Despite forward positioning requirements, MLRS units do not normally receive any logistical support from DISCOM forward support battalions (FSB).

The COSCOM provides CSS mainly through two types of major subordinate elements: corps-wide service organizations and support battalions, groups, or brigades. The method of providing support is based on the size of the corps, the organization of the COSCOM, the number of units to be supported, and the tactical situation. The COSCOM augments support to the divisions and provides CSS to nondivisional units under the control of the corps, including the Corps MLRS battalions.

The MLRS units, through their parent headquarters, should coordinate to draw logistics support from the closest support area available. The CSS of support areas varies; not all will be able to support an MLRS unit with all of the CSS functions and services required. For example, MLRS units often must obtain ammunition from an ATP or ASP established or augmented by corps.

The MLRS battalion must be flexible in obtaining support. Dispersion throughout the corps area may dictate nonstandard methods of support. For example, a battery conducting independent operations could obtain a portion

## FM 6-60

of its support from the closest divisional FSB and the remainder from the MSB. It may change supporting units during the operation on the basis of a change of missions. The battalion XO must ensure that this support is thoroughly coordinated with both the DS unit and the supported battery.

### Logistics Operations

#### Battalion Level

The battalion trains is a grouping of personnel, equipment, and vehicles that provide very limited logistical support to the batteries. The primary function of these trains is staff coordination with external support agencies. The battalion trains normally operates under the control of the ALOC. The organization of the MLRS battalion trains varies with the mission and tactical situation as well as the other factors of METT-T. The battalion trains is typically a small organization with few assets. Unlike the traditional FA HHB and service batteries, the MLRS battalion HHS battery has few organic CSS assets. The HHS is organized and equipped primarily to provide combat support to itself. Staff elements provide coordination with external agencies to facilitate logistics activities and resupply. The battalion maintenance section also provides support to the entire battalion in the areas of scheduled maintenance, overflow unscheduled maintenance, and recovery. Most of the battalion CSS assets are organic to the firing batteries, thereby facilitating dispersed operations. The battalion can locate its trains near a logistics support area to facilitate coordination for logistics support. To facilitate resupply of the batteries, however, the trains may be centrally located on the battlefield.

When possible, supplies are delivered directly to the firing batteries. This is unit distribution. Batteries normally will draw supplies from a distribution point. This is supply point distribution. Direct distribution from division and corps support units is another form of unit distribution. Intermediate locations or units are bypassed to save time and resources.

The logistics operations within MLRS battalions are geared to be decentralized in control. This allows MLRS firing batteries to operate autonomously and/or on a wide front. CSS assets are organic to MLRS firing units to allow them to conduct their own maintenance and resupply operations. There are three options available to MLRS battalions to monitor and coordinate logistics.

#### Option 1- Decentralized Control

Logistics functions within MLRS units are best suited to decentralized control. The units are already equipped and manned to operate in this manner. Under decentralized logistics control, the BC, with assistance from the battery LOC, is responsible for ensuring adequate quantities of Class I, III, V, and IX are on hand to support the battery. The Bn or div arty ALOC simply coordinates for the unit to draw these items and processes/forwards requests as appropriate. Decentralized logistics operations allow for dual, mixed or consolidated CPs (as discussed in Chapter 4).

##### Advantages to Decentralized Control:

- Supports ability to employ autonomously.
- Provides the most flexibility at battery level.
- Dispersion enhances survivability of CSS assets battalion wide.

##### Disadvantages to Decentralized Control:

- Requires more vehicular traffic in and out of the battery area increasing chances that firing batteries will be observed by enemy forces.
- Personnel intensive - each firing battery works separately to firing the same logistical requirements.

#### Option 2- Centralized Control

MLRS units may centralize control of logistics operations within the battalion. However, since the Bn ALOC is not manned to perform consolidated logistics functions, and MLRS firing units are resourced to be predominantly self-sustaining, centralizing logistical functions call for drastic changes in the doctrinal employment techniques for MLRS battalions. During centralized logistic operations, the Bn ALOC would assume control of all logistics functions and assets in the batteries and battalion. This includes fueling, sustaining, fixing, and arming. The sections that perform these functions would most likely collocate within the area of operations and the Bn ALOC would control their actions. Under this system, the Bn would maximize the use of Logistics RPs to distribute logistics packages. Additionally, the Bn would employ internal maintenance and ammunition haul assets forward to facilitate firing battery operations. Due to the large



amount of vehicles and support equipment, centralized logistics operations do not lend themselves to consolidated CP operations (as discussed in Chapter 4).

**Advantages** to Centralized Control:

- Enhances survivability of firing units by reducing their signature.
- Removes logistics support strain from the battery.
- Reduces security risks to logistics vehicles (reduces the amount of vehicles required to be on the road).
- Streamlines logistics functions through the efficient management of personnel.
- Increases logistic assets point defense capabilities.

**Disadvantages** to Centralized Control:

- CSS assets, when centralized, become a lucrative target.
- Battery turnaround time for resupply may increase.
- Additional terrain is required to support the trains location.
- Impairs ability to employ a firing battery autonomously.

**Option 3- Shared Control**

This option of conducting logistics operations is simply a combination of the two options previously discussed. METT-T may dictate that certain logistics functions -- for example, fueling, or arming-- be centralized at battalion

level. The Bn may establish an AHA or a refuel point, etc. to support the overall battalion mission. Under this option all or simply part of certain logistics sections may be centralized into a unit trains location in order to best support the unit's mission. Shared control logistics operations lend themselves to dual, mixed, or consolidated CPs (as discussed in Chapter 4).

**Advantages** to Shared Control:

- Maximizes flexibility by focusing critical logistics efforts in appropriate areas.
- Reduces a logistics burden in specific areas.

**Disadvantages** to Shared Control:

- Increases logistics C2 strain on ALOC because of manpower constraints.

**Battery Level**

An MLRS battery commander may choose to split his logistics element from the BOC. It then operates under the control of the LOC (see Chapter 3 for more information). The battery 1SG normally establishes logistics release points (LRPs) in order to push routine supplies forward and facilitate other routine administration. Firing platoon sergeants normally meet the 1SG at the LRP on a daily basis or IAW unit SOP.

MLRS firing platoons have no organic logistics support assets. Firing platoons are completely dependent upon the parent Battery headquarters for this support. Although some battery assets lend themselves to decentralizing, this limits the operational flexibility of the battery and could adversely impact on the support of other firing platoons.

---

## Section II MANNING

---

The systems of personnel readiness management, replacement management, and casualty management meet the Army personnel requirements from mobilization and deployment through redeployment and demobilization. The Army personnel readiness system provides a flexible tool for selecting and assigning soldiers with the correct skills to meet the requirements before, during, and after combat. The replacement management system moves soldiers and civilians through the continental United States (CONUS) replacement centers to unit commanders in the theater of operations. The replacement system responds to commanders through the personnel-readiness management system. Casualty management helps the personnel-readiness manager replace losses incurred during battle (FM 100-5).

---

### Personnel Readiness Management

Strength accounting is the process by which combat readiness (personnel status) is measured. It keeps track of the troops on hand, identifies those that have been lost, and identifies those that are needed. The MLRS battalion S1 (1SG for divisional MLRS batteries) serves as a conduit between subordinate units and the higher headquarters.

Batteries submit a daily personnel summary report to the battalion S1 in the battalion trains. He then forwards a consolidated battalion report. The divisional MLRS battery submits its report to div arty. These reports, together with authorized vacancies, are the basis for requesting individual replacements. Accurate strength reports also give the commander and staff information to plan future operations. The unit SOP provides guidelines for the report.

### Replacement Management

The battalion S1 is the MLRS battalion commander's staff officer for individual personnel replacement operations. Personnel requirement reports and loss estimates determine the replacement requirement. The division or corps AG, on the basis of documented losses, replacement projections, and the division commander's priorities, prepares replacement distribution projections. The corps AG prepares a similar report to the corps artillery G1. Replacements are delivered to the unit through the BSA or DSA for the divisional MLRS battery and through the COSCOM for the nondivisional corps MLRS battalion.

Replacement flow is monitored by the battalion S1. All replacements or returnees are brought to the ALOC for initial processing. Hospital returnees are handled as replacements by the division AG. Replacements are equipped with needed field gear before leaving the ALOC.

### Casualty Management

The main personnel accounting function on the battlefield is casualty reporting. The casualty reporting system, a by-name personnel accounting system, begins at unit level with the person who knows that a casualty has occurred. Casualty information must be reported with 100-percent accuracy as quickly as the situation permits.

During combat operations, the S1 (1SG for divisional MLRS batteries) must make sure that strength and casualty reports are timely and accurate. Casualty reports give the detailed information needed to requisition specific replacements. Casualty reporting occurs as soon as possible after the event and is started by the section chief or battery commander. A DA Form 1156 (Casualty Feeder Report) is carried by all small-unit leaders to report hostile-action casualties and non-hostile-action casualties. It provides initial information to the adjutant general (AG) for preparing the casualty report. This report is used by Department of the Army (DA) to notify next of kin. Also, it validates the soldier's line-of-duty status, which determines payment of benefits. Casualties are reported to the 1SG, who collects the reports and forwards them to the PAC. Reports are forwarded through the FA brigade HQ for nondivisional MLRS units under corps control. Reports are forwarded through the div arty HQ for the divisional MLRS battery.

---

## Section III ARMING

---

**During periods of intense combat, arming the force is extensive and time-sensitive. It begins with peacetime planning and covers all phases of force-projection operations. Arming the force requires detailed planning and coordination among the combat users and the ammunition and transportation logisticians at all levels. Modern warfare consumes large amounts of ammunition. Much of the Army's ordnance depends on high-quality electronic and optical technologies for precision and effectiveness. Logistics provides the total package of components, technical maintenance, and skilled soldiers to keep weapons systems firing. The key to arming soldiers in the field is planning for a flexible logistics distribution system capable of surging for the main effort. Given the large variety of ammunition and weapons in use and the fluid nature of battle, arming soldiers has become an even greater challenge (FM 100-5).**

---

### General

The MLRS units operate throughout division and corps (including covering force) sectors. They have unique ammunition requirements, resupply vehicles, and procedures. The MLRS family of munitions is described in Chapter 1. The following descriptions of ammo agencies and terms apply to all MLRS units.

#### Terms

**Corps Storage Area (CSA).** The corps storage area (CSA) is located 170-190 km behind the FLOT, deep in the corps support area. It is the main source of ammunition for all FA units in the caps area. The GS ammo company operating the CSA pushes ammunition forward to the ASPs and the ATPs with corps transportation assets.

**Ammunition Supply Point (ASP).** The ASPs are alternate sources of ammunition for units located in a division area (ATPs are the primary). The ASPs are operated by the COSCOM DS ammunition company. Stocks, including MLRS, are managed by the COSCOM MMC and are based on requirements determined by the DAO and the division materiel management center (DMMC).

**Ammunition Transfer Point (ATP).** Artillery units located in a division area normally receive 100 percent of their ammunition requirements at an ATP. Normally, there are four ATPs in a division area.

Each forward support area battalion operates an ATP in its BSA. These ATPs service mainly the maneuver brigade and the cannon FA battalions operating in the brigade

zone. The fourth ATP (divisional ATP), operated by the DS ammunition company, is located in the DSA. It is located approximately 35 to 45 kilometers from the FLOT and is designed to provide the required lift and transload capability for the divisional MLRS unit, corps MLRS units, and all cannon artillery units supporting the division. The MLRS unit draws ammunition from the ATP designated by the DAO.

The MLRS units that have been postured for corps deep attack missions and are positioned in a division area normally will draw Army TACMS variants from the ASP. However, these items may require extraordinary asset management and distribution to ensure the right ammunition is available to the right weapons systems at the right time. With proper planning and coordination, Corps will push Army TACMS forward to the appropriate ATP. Another option to expedite reaction time would be to provide Army TACMS from the CSA or ASP to the ATP or unit trains by air.

**Note:** Only under the most unusual or emergency circumstances will an MLRS unit use its organic assets to draw ammunition from the CSA.

The MLRS battery ammunition platoon leaders and MLRS battalion S4s must coordinate with the DAO and the ATP to ensure MLRS needs are met at the nearest ATP. Normally, MLRS ammunition is left on the corps transportation vehicle trailers at the ATP. The MLRS unit personnel transload launch pods from the trailers by using organic material handling equipment. Often, the MLRS transfer point is actually outside of, and adjacent to the ATP.

**Ammunition Holding Area (AHA).** The AHAs can be established at MLRS platoon, battery and/or battalion levels. Normally, AHAs are only required at the platoon level during the initial phase of an operation in order to have ammunition as far forward as possible. Once hostilities commence, the trucks will normally not be held at a platoon OPAREA. This would slow resupply and ultimately impact on the fire mission rate. The HEMTT-HEMATs of the ammunition platoon maybe held in the battery or battalion AHA between resupply missions depending upon unit TSOP. The location of AHAs and the crewmen duties in these areas vary according to unit SOP (see Chapter 4).

**Reload Point (RL).** The RLs are the locations in the platoon OPAREA where M270 launchers down-load expended launch pods, up-load new launch pods, and rendezvous for other resupply items. At least two RLs per OPAREA are recommended. These requirements may vary with METT-T (see Chapter 4).

**Basic Load.** Class V UBL consists of quantities of conventional ammunition required to sustain the unit during combat until normal resupply can be conducted. The basic load must be available for the unit to carry into combat with its organic transportation assets.

The Class V UBL stockage level is established by the major by command (MACOM). It includes MLRS launch pods, small arms ammunition, explosives, mines, fuzes, detonators, pyrotechnics, and associated items. It does not include TOE/MTOE items, such as explosive components of sets or kits although they are stored and uploaded along with the class V UBL (see Table 6-1 ).

**Required Supply Rate.** The required supply rate (RSR) is the estimate of the amount of ammunition needed to sustain operations, without restrictions, for a specific length of time. The RSR is a result of the unit forecast for ammunition, which is based on the tactical situation and mission. The MLRS battalion S3 and div arty S3 are responsible for determining ammo requirements and submitting forecasts to the next higher headquarters. The RSR is expressed in terms of rounds per unit, per individual, or per weapon per day or as LPCs per launcher per day. The unit RSR is reported as part of operations or logistics reports. These requirements are compared with assets expected to be available for the period to determine the CSR.

**Controlled Supply Rate.** The CSR is the amount of ammunition use that can be sustained with available

assets. The CSR also is expressed as rounds per unit, per individual, or per weapon per day. The CSR can also be expressed in terms of LPCs per launcher per day. The theater commander determines the CSR for each item of ammunition. In turn, the commander of each subordinate tactical unit determines a CSR for his units at the lower levels. The CSRs for individual items may vary from one command to the next. The corps commander uses the CSR to prioritize unit ability to expend ammunition, consistent with the mission requirements of the overall force. This ensures enough ammunition for all units on the basis of their missions. The CSR may be communicated to subordinate commands through the logistic support channels; or it may be published in the OPORD, a fragmentary order (FRAGO), or the fire support portion of the OPORD. The statement "The CSR is the RSR" is used if there are no restrictions. Except in emergency situations, units may not draw more than their CSRs without authority from their next higher headquarters.

**Expenditure Rates.** Each MLRS unit (launcher) expends a certain number of rounds per launcher per day based on the operational and tactical situation. Corps and theater stockage objectives are based on the projected intensity of battle. These objectives are expressed as days of supply (DOS) per type of ammunition. Consumption rates of ammunition may be expressed as an average of rounds per weapon per day to support a given force. A method of determining the anticipated consumption rates for MLRS units is by use of a **mission profile**, or measure of the effort expected of a system under various levels of combat intensity. The mission profile for MLRS consists of estimates for three levels of combat intensity. These levels of intensity are defined as follows:

- **Sustained.** This is the level of effort expended per day over an extended period of combat for a committed force. This level is normally expected to occur 75 percent of the time for MLRS units.
- **Surge.** This is the level of effort expended when a committed force faces a main attack. This level is normally expected to occur less than 20 percent of the time for MLRS units.
- **Peak.** This is the level of effort expended during an intense period of combat, and is most likely to occur for direct support and/or reinforcing artillery with a brigade area. This level is normally expected to occur less than 5 percent of the time for MLRS units.

**Table 6-1. Ammunition Identification Chart**

Launch Pod Munition Type	J-Code	DODAC		Corner Marker	Upper Small Square	Lower Small Square
		FSC	DODIC			
M26 Rocket (M77 DPICM)	JED	1340	H104	Yellow	None	Brown
AT2 Rocket	JMT	GERMANY AND UK ONLY				
M28 Rocket (Training)	JED	1340	H108	Blue	Light Green	Brown
M28A1 Rocket (Training)	JEH	1340	H185	Blue w/"RR"	Light Green	Brown
XM29 Rocket (Training)	JTB			Black w/Yellow Circle	Brown	
ER Rocket (XM85 DPICM)	JEL					
ERG Rocket (XM85 DPICM)						
M39 ATACMS (M74 APAM)	JEE	1427	PL81	Yellow		
ATACMS IA (M74 APAM)	JEN					
ATACMS II (BAT)	JTC					
ATACMS IIA (BAT)	JTG					

**Ammunition Expenditure**

**M26 Rockets.** The rocket data below was originally developed from the Firefinder II Abbreviated Analysis portion of the Counterfire Study, scaled to the European scenario. A similar analysis conducted in 1994 to support MFOM development yielded nearly identical results.

**M39 Missile.** Although Army TACMS expenditures are unique to the theater and mission requirements of the JTF or corps commander, Table 6-2 shows the daily planning figures for the three levels of combat intensity described above:

**Table 6-2. Ammunition Expenditure**

LEVEL	Rkt/Lchr/Day		Msl/Lchr/Day	
	Quantity	Mean	Quantity	Mean
<b>Sustained (.75)</b>	3-130	80	1-6	4
<b>Surge (.20)</b>	130-175	150	6-8	7
<b>Peak (.05)</b>	175-263	195	8-12	9
<b>Total Mean</b>		100		5

The actual number of missions and munitions is determined by SOP, commander's criteria, and the staff planning process. It is a function of the number and types of targets which will be engaged, and size and location

errors associated with each target. In addition to the anticipated level of effort described above. The CSR and other restrictions established by the JTF, corps, or division commander will effect the stockage and resupply of munitions, especially Army TACMS.

### Resupply Operations

Ammunition is normally drawn from a division or corps ATP or ASP (see Figure 6-2). If low density munitions are stored at different locations, the unit may need to dedicate appropriate resupply assets as required. Based on the tactical situation, ammunition platoons organic to batteries can be task-organized in several ways to accomplish the mission of resupply. These methods are based on the level (platoon, battery, battalion) that is responsible for control of ammunition resupply operations.

#### Decentralized Control

This method places a number of ammunition HEMTT/HEMATs under the control of the firing platoons. The firing platoon sergeant is then responsible for the flow of ammunition from the ATP or ASP directly to the platoon resupply points.

#### Centralized Control

Under centralized control of ammunition resupply operations, the battery commander retains control of organic HEMTT/HEMATs and manages ammunition resupply operations at battery level (LOC).

#### Shared Control

The battalion commander may consolidate control of some of the HEMTT/HEMATs from the batteries into a battalion ammunition resupply platoon and manage all Class V resupply operations.

Leaders must consider several things when task organizing ammunition resupply assets:

- **Tactical fire direction.** Echelons that are responsible for tactical fire direction should retain enough control to maintain an ability to redirect the flow of ammunition resupply.
- **Distances to and from units/ATPs.** The farther the ASP/ATP is from the unit, the greater the need to consolidate or centralize at least a portion of the

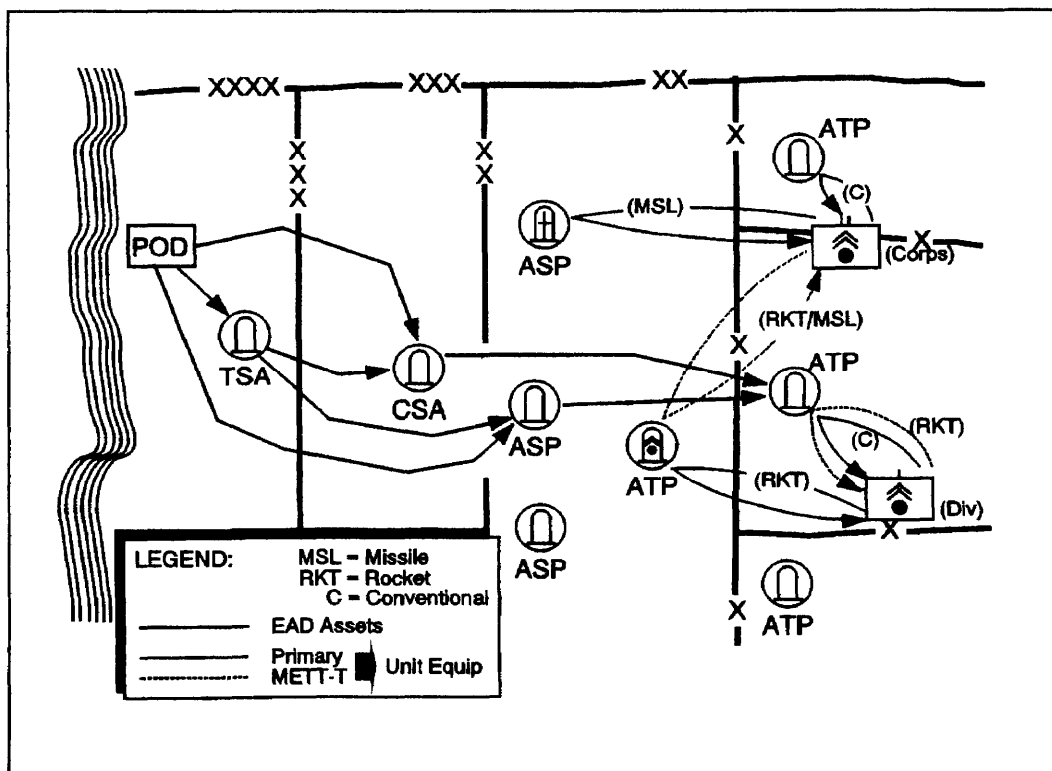

Figure 6-2. Ammunition resupply.

assets. This will increase control and reduce navigational errors.

- **Expected rates of fire.** Higher rates of fire may require a less centralized approach. This reduces the number of stops an ammunition crew makes throughout the resupply cycle.
- **Number of trucks and trailers available.** Fewer trucks may require less centralized methods of ammunition resupply in order to maintain sustained rates of fire.
- **Soldiers' land navigation skills.** Units having soldiers with weak mounted land navigation skills may require more control in managing resupply and thus take a more centralized approach.

- **Refueling requirements for HEMTTs.**
- **Other Class V requirements.**
- **Maintenance of equipment.** Swapping trucks at either the battery or battalion AHA in order to prevent long transload times is not without problems. Crews that don't feel ownership for their vehicle are less likely to maintain it properly.

### Resupply by Air

Aviation assets can be used to transport limited quantities of ammunition. However, transport of MLRS ammunition by air may not be practical given the limited haul capacity of rotary aircraft (see Appendix A).

---

## Section IV FIXING

---

**Maximizing equipment availability is a necessity in supporting a force-projection army. Sound maintenance practices in all units, forward positioning of maintenance capabilities, quickly accessible repair parts, and well-understood priorities for recovery and repair may spell the difference between success and failure. Repairing equipment far forward is key. A tailored maintenance capability will deploy, move with, and redeploy with supported units. Modular support teams will provide additional capabilities. Battle damage assessment and repair (BDAR) provides the capability to quickly repair and return equipment to combat or expedite recovery and evacuation to the closest maintenance facility with required capabilities. The maintenance focus is on supporting combat operations (FM 100-5).**

---

### General

A successful maintenance program depends on a concentrated effort by all personnel in the unit to maintain equipment in a serviceable condition. The operational requirements and sophisticated equipment of the MLRS unit require that most maintenance be done at an operational site as far forward as possible. Therefore, maintenance support teams must include the skilled personnel, proper tools, test equipment, and necessary repair parts.

### Terms

A **maintenance support team (MST)** is a mobile team organized and equipped to provide forward support.

A **unit maintenance collection point (UMCP)** is a location established by the battalion maintenance section

to collect equipment awaiting repair, evacuation, controlled exchange, or cannibalization. It is the first point to which battery maintenance teams evacuate equipment.

**Cannibalization** is the authorized removal of parts or components from uneconomically repairable or disposable end items or assemblies and making them available for reuse.

**Controlled substitution** is the authorized removal of serviceable parts, components, or assemblies from unserviceable, economically repairable equipment and their immediate reuse in restoring a like item to combat-operable or serviceable condition. Removed components must be replaced as soon as possible.

**Battlefield damage assessment and repair (BDAR)** is the act of inspecting battle damage to determine its extent, classifying the type of repairs required, and determining

## FM 6-60

the procedure best suited to make the equipment mission-capable. BDAR may involve the immediate repair of equipment by field-expedient methods; however, BDAR procedures will be used only in combat, at the direction of the commander and IAW applicable technical manuals.

**Line replaceable units (LRU)** are high value, modular replacement components designed to facilitate swift repair of M270 launchers. There are eight LRUs, six maintained on unit PLL and two maintained by the 27M MST.

### Levels of Maintenance

The Army maintenance system consists of four distinct levels, or categories, of maintenance as follows:

- Unit
- Intermediate
  - Direct support.
  - General support.
- Depot.

### Unit Maintenance

The cornerstone of unit maintenance is the operator and/or crew performing PMCS from the applicable TM -10 and -20 series. Unit maintenance is characterized by the isolation of faults by using built-in or automatic test equipment, by visual inspections, by minor adjustments, and by the exchange of faulty modules and components. Unit mechanics also perform recovery tasks. All MLRS crew members are able to perform organizational (-20 level) maintenance on the LLM.

### Intermediate Direct Support Maintenance

The MLRS units depend on their DS unit for assistance when equipment needs maintenance support beyond the organic capabilities of the battery and battalion. The heavy division MSB provides support to divisional MLRS units. The corps MLRS units receive direct support maintenance from maintenance companies within corps ordnance support battalions. This applies to both automotive and missile direct support. The heavy maintenance and electronic maintenance companies provide DS automotive maintenance and MLRS-specific support for the divisional MLRS unit.

Intermediate DS maintenance personnel diagnose and fault-isolate equipment or module failure, adjust and align modules and components, and repair defective end items. DS maintenance is comprised of two separate functions:

- Automotive and track vehicle.
- Electronic repair.

**Automotive and track vehicle maintenance** is accomplished by a main maintenance company. The main maintenance company operates a repairable exchange (RX) activity, performs light body repair, and provides backup recovery support to the HHS maintenance section. Electronic repair is accomplished by the electronic maintenance company (ELMC). The ELMC operates a technical supply and RX activity for electronic maintenance support. The ELMC has tailored MST to support the battalion. The FCSB normally contains MSTs for both automotive and missile support for the corps MLRS battalion. Divisional MLRS units will normally receive only MSTs for missile maintenance support from the division MSB.

### Intermediate General Support

Intermediate GS maintenance provides maintenance support to the MSB's technical supply RX activity for both the divisional and corps MLRS units. The GS unit also provides Army TACMS surveillance and GMLA minor repair support to ammunition storage facilities.

### Depot Maintenance

Depot maintenance provides technical support and backup to DS and GS maintenance units. It consists of repair or overhaul of economically repairable components and end items. Such maintenance is intended to augment stocks of unserviceable equipment and to support lower levels of maintenance. Depot maintenance requires extensive shop equipment and personnel with greater technical skills than are required in organizational and intermediate maintenance activities. It can provide combat-ready materiel to the Army supply system.

### Battalion Maintenance Support

The battalion maintenance section consists of supervisory, supply, maintenance, and recovery personnel. The battalion maintenance officer and technician give technical advice and expertise to the battalion and battery



commanders. The BMO coordinates maintenance and Class IX supply with the DS MSTs. When supporting MAGTF operations, the BMO interacts with the Marine combat service support detachment (CSSD) when coordinating Class IX resupply or facilitating overflow DS maintenance support. If the MLRS battery is without a battalion HQ, the above maintenance support responsibilities fall on the battery maintenance officer (normally, the ammunition platoon leader) and motor sergeant. This section provides the overflow organizational maintenance support, as well as recovery and scheduled services support.

The HHS maintenance section provides unit-level maintenance and recovery support to HHS elements. This support includes performing scheduled services, unscheduled maintenance, and recovery.

**Maintenance Forward**

Combat power is maximized when disabled equipment is repaired as far forward and as quickly as possible. The BMO, in coordination with the XO, directs the maintenance effort for the battalion. He uses established time guidelines and coordinates maintenance actions.

Battle damage assessment and diagnosis determine repair time. An item is repaired on site or recovered directly to the appropriate maintenance echelon in the appropriate support area. The location is based on the following:

- Tactical situation.
- Echelon of work required.
- Availability of required repair parts.
- Current workload in each area.
- Maintenance time guidelines.

Maintenance time guidelines establish the maximum time that unserviceable equipment will remain in various support areas. The decision to repair, recover, or evacuate is made at all levels and is based on the time required to repair. Those times are based on command policy and the factors of METT-T. They do not include evacuation, preparation, and movement time. The maintenance times shown in Table 6-3 are flexible and should not be considered restrictive.

**Table 6-3. Maintenance Time Guidelines**

<b>TIME FOR REPAIRS (HOURS)</b>	<b>LOCATION</b>
<b>Less than 2</b>	<b>On Site</b>
<b>2 to 6 (and can be towed until repaired)</b>	<b>Battery LOC</b>
<b>6 to 24 (or less than 6 if vehicle cannot be towed)</b>	<b>UMCP</b>
<b>24 to 36</b>	<b>ALOC/FCSB Maint Company</b>

The UMCP is normally established at a centralized point that can easily support all units organic and attached to the Bn. It includes the Bn maintenance section and the automotive DS MST. The UMCP is not a “one stop-fix-it shop,” rather a designated location for units to evacuate equipment for repair that may or may not require assistance from the MSTs or the Bn maint section. The UMCP must not become a collection point for non operational vehicles to the extent that it cannot move with reasonable notice. Anything that cannot be repaired or towed by UMCP assets is immediately recovered to the appropriate location. The UMCP is supervised by the BMO and BMT.

During periods of frequent displacement, the BMO may direct that the UMCP displace by echelon. In this case, some personnel of the maintenance platoon, including the BMO, complete repair on vehicles at the existing UMCP before displacing forward to the new location. Maintenance assets that are not involved in repairs can move with the rest of the unit trains and establish the forward UMCP.

During rapid forward moves, the UMCP conducts only essential repairs and simple recovery. Other disabled vehicles are taken to collection points on the MSR. They remain there to be repaired or evacuated. Multiple collection points may be beyond the C2 capability of the battalion.

**Firing Battery Maintenance Operations**

Each MLRS battery is designed to perform its own organizational maintenance. The structure of the MLRS

## FM 6-60

battery maintenance section supports unit ability to conduct independent operations. Unit-level maintenance on the FCS/LLM is performed by the crew. They must work closely with the maintenance section for repair parts support and to coordinate for DS MST assistance. All other unit organizational maintenance repair for all organic and attached equipment is performed by the MLRS battery maintenance section.

The MLRS maintenance concept is based on the established conventional levels of maintenance (unit, DS, GS, and depot) with use of specialized maintenance teams. (See Figure 6-3, page 6-13.)

**FCS Related Maintenance.** The FCS incorporates built-in test equipment (BITE) to help the crew maintain system performance. This BITE continually monitors the FCS components and functions. If a failure occurs, the crew is notified by illumination of a status light or by a fault message on the FCP. If the fault is serious, any ongoing mission is automatically stopped. When a fault indication is received, the crew refers to corrective actions in the troubleshooting section of the technical manual. If the fault cannot be corrected by the prescribed actions and more testing is required, the mechanic does the following:

- Calls up his diagnostic menu.
- Selects the test indicated by the troubleshooting table.
- Performs checks indicated by the table or by the FCP prompts.

Usually, completion of these checks results in the requirement for component replacement, RX at unit level, or notification of DS MST personnel.

**Non-FCS Maintenance.** Unit maintenance repair other than FCS repair is performed by the MLRS battery maintenance section. Operator-detected faults which cannot be corrected by troubleshooting are reported to the platoon HQ. The HQ coordinates with the BOC or maintenance section for support.

Defective assemblies, modules, and parts not authorized for repair at unit level are evacuated to the appropriate DS facility for exchange or repair.

### Recovery

Recovery of MLRS equipment is a critical function of the unit maintenance program. The two-vehicle recovery capability of the battery and the possible wide dispersion

of battery elements can require the use of self-recovery techniques within the platoons. Limited additional recovery support is available at battalion for nondivisional units. Recovery beyond the unit organic capability must be obtained from the supporting maintenance unit.

### Communications Maintenance

Direct support communications maintenance support will be accomplished by the ELMC. An austere signal section is authorized for repair of communications equipment. Troubleshooting by operators and evacuation to the support maintenance signal repair unit is the usual maintenance procedure.

### Fire Direction System

DS FDS maintenance will be accomplished by the ELMC. The FDS accomplishes internal software fault detection and isolation for unit maintenance. No organizational maintenance is authorized on the AN/GYK-37, LCU other than PMCS.

### Maintenance Support Teams

Repair of MLRS specific components (FCS/LLM) is facilitated by the MOS 27M MSTs from the respective DS Missile Support units. This MST collocates with the MLRS unit normally down to battery level. The MST foreman responds to request for direct support by dispatching MLRS repairers to the platoon area to repair a non operational launcher on site. The MST representatives may collocate with the LOC to receive requests via FM voice radio. This allows them to troubleshoot before the MST is dispatched and to prioritize the maintenance workload. The MLRS platoon leader assumes responsibility for the MST when it is in the platoon area. He releases the MST to return to the battery LOC when the maintenance mission is complete. The MSTs also may be attached to the firing platoons for the duration of operations. This facilitates rapid fault diagnosis and repair, but limits flexibility. Automotive maintenance support may be provided by forward contact teams, or the vehicles may be consolidated at the battery headquarters and evacuated to a maintenance unit or specified location. Both teams may be augmented as needed by members from corps GS units.

### Class IX: Repair Parts

Class IX is made up of those repairable components, kits, assemblies, and subassemblies (serviceable and unserviceable) that are required for maintenance support

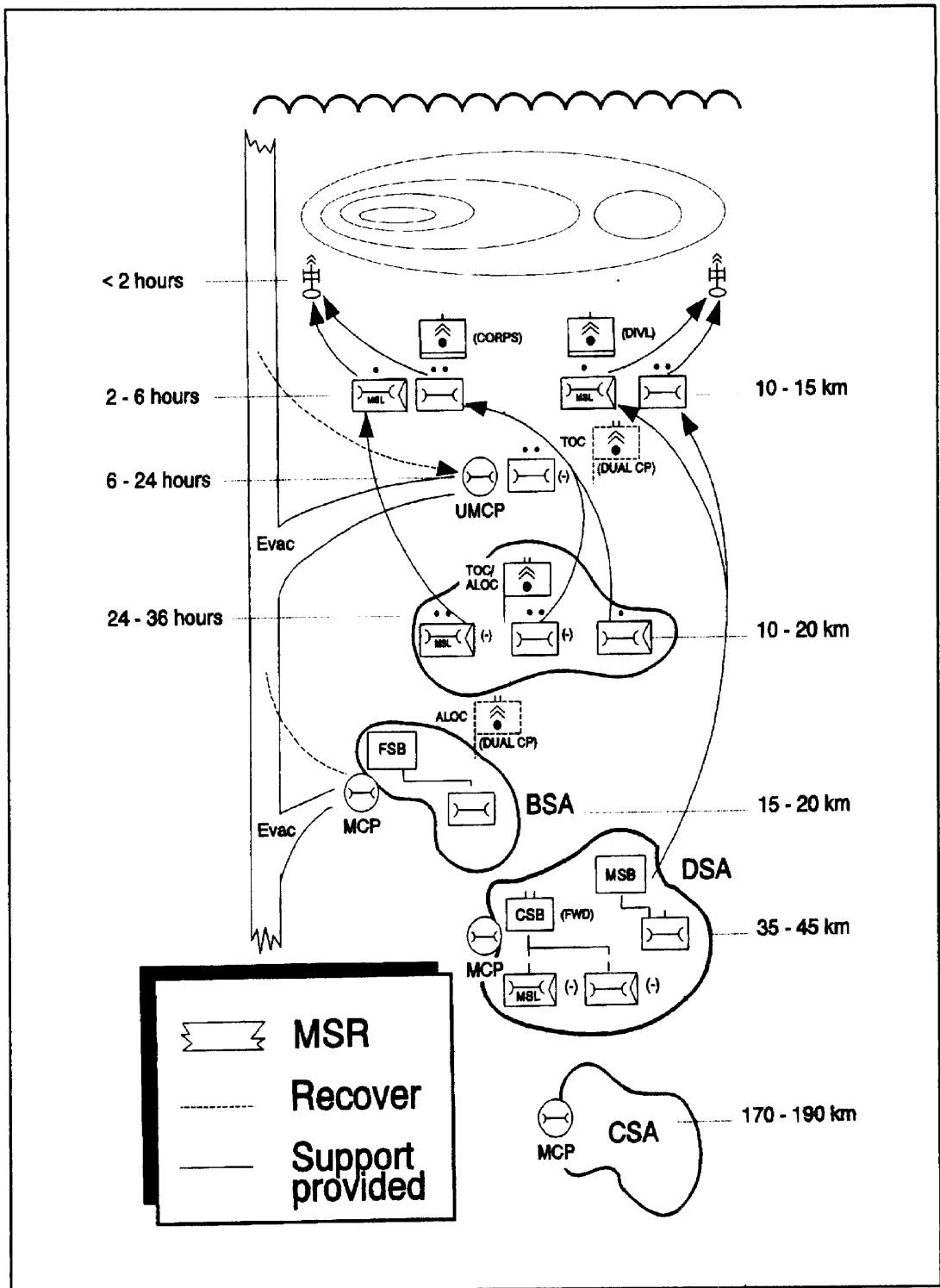

Figure 6-3. Maintenance operations.

## FM 6-60

of all equipment (less medical-peculiar repair parts). Minor repairable components are included in Class IX repair parts. To recover and repair these items, they are treated as RX items. Class IX items required for support of SIGINT equipment are drawn from the supporting signal battalion.

Requisitioning Class IX items is unique, as it is done through the maintenance support structure. Units maintain a stockage of parts to meet immediate needs. At the unit level, this is called PLL. Maintenance units keep a stockage of parts to meet the immediate needs of the units they support. This stockage is the authorized stockage list (ASL). Unit Class IX PLL replenishment is obtained from the maintenance support company. An unserviceable RX item is exchanged at the maintenance support activity for a serviceable like item.

Requests for Class IX repair parts are submitted to the Class IX section of the maintenance unit which supports the MLRS unit. The maintenance unit issues the part from the ASL, if it is on hand. Request from supported units which cannot be filled by the maintenance company or activity are forwarded to the materiel management center (MMC). The MMC issues the part from the ASL of another maintenance unit; or, if the part is unavailable, the appropriate support command (DISCOM or COSCOM) orders it.

Class IX items that arrive in the corps (for MLRS battalions under corps control) or division (for divisional MLRS units) are received by the maintenance unit which supports that MLRS unit. The supported unit normally picks up the Class IX parts from the support maintenance unit, however, they may be delivered to the unit.

---

## Section V FUELING

---

**While the high performance air and ground vehicles of the Army furnish great potential mobility for both heavy and light forces, they also consume large quantities of fuel. Wheeled vehicles use less fuel than tracked vehicles and heavy equipment but still make great cumulative demands on the logistics system. Providing clear priorities for fueling, accurately estimating fuel consumption, and economizing assets whenever possible contribute to ensuring adequate support of operations. Logisticians operate a high-volume refueling system to support routine consumption rates; they also provide a surge capability. In peak consumption periods, victory may depend on the ability of the logistics system to increase the flow of fuel. Whether combat, CS, or CSS, all units require uninterrupted fueling to function effectively (FM 100-5).**

---

### General

Class III supplies include petroleum fuels, lubricants, hydraulic and insulating oils, and antifreeze. Requisitioning of Class III supplies begins with a forecast submitted by the unit to the appropriate support area. The external SOPs of the support unit dictate the frequency of the reports. The forecast may be based on FM 101-10-1/2, historical data reflecting consumption rates, or experience.

### Fuel

On the basis of the forecasts, fuel is supplied to the forward distribution points. Here the units draw Class III supplies from their supporting logistics unit on an as-required basis. In emergency situations, the corps has a limited capability to provide direct shipments of bulk Class III to the consuming divisional units or as far forward as practical. A combination of unit and supply point distribution is used (see Figure 6-4, page 6-16).

Normally, MLRS battery POL resupply operations are managed by the first sergeant and conducted by the battery supply section. Battery POL tankers are sent to the nearest supporting forward distribution point, refueled, and returned to the battery area. Because of the operational distances an MLRS unit may have to cover, the MLRS unit commander may have to coordinate Class III resupply

for MLRS batteries and/or platoons with other units. Battery refueling operations can be carried out in the following manner:

- **Hot Refuel.** All vehicles refuel during movement enroute to new OPAREAs. Based on METT-T, commanders will determine the amount of time and fuel available for each vehicle. This is the preferred method.
- **OPAREA Refuel.** The fuel truck is taken to the platoon OPAREAs. The fuel truck is then taken to individual vehicle positions or the vehicles move to the centrally located fuel truck. This option is the least preferred because of the potential that it may unnecessarily reveal firing platoon/launcher positions.

### Packaged Class III

Packaged class III supplies are requested and distributed like class II and IV items. Items include fuel in 5, 55, and 500 gallon containers; packaged products such as lubricants, greases, hydraulic fluids; solvents in containers of 55 gallons or less; and cylinders of liquid and compressed gases. To maintain mobility, stockage is restricted to limited high demand items. The receipt, storage, and issue of packaged petroleum products and fuels are described in FM 10-69.

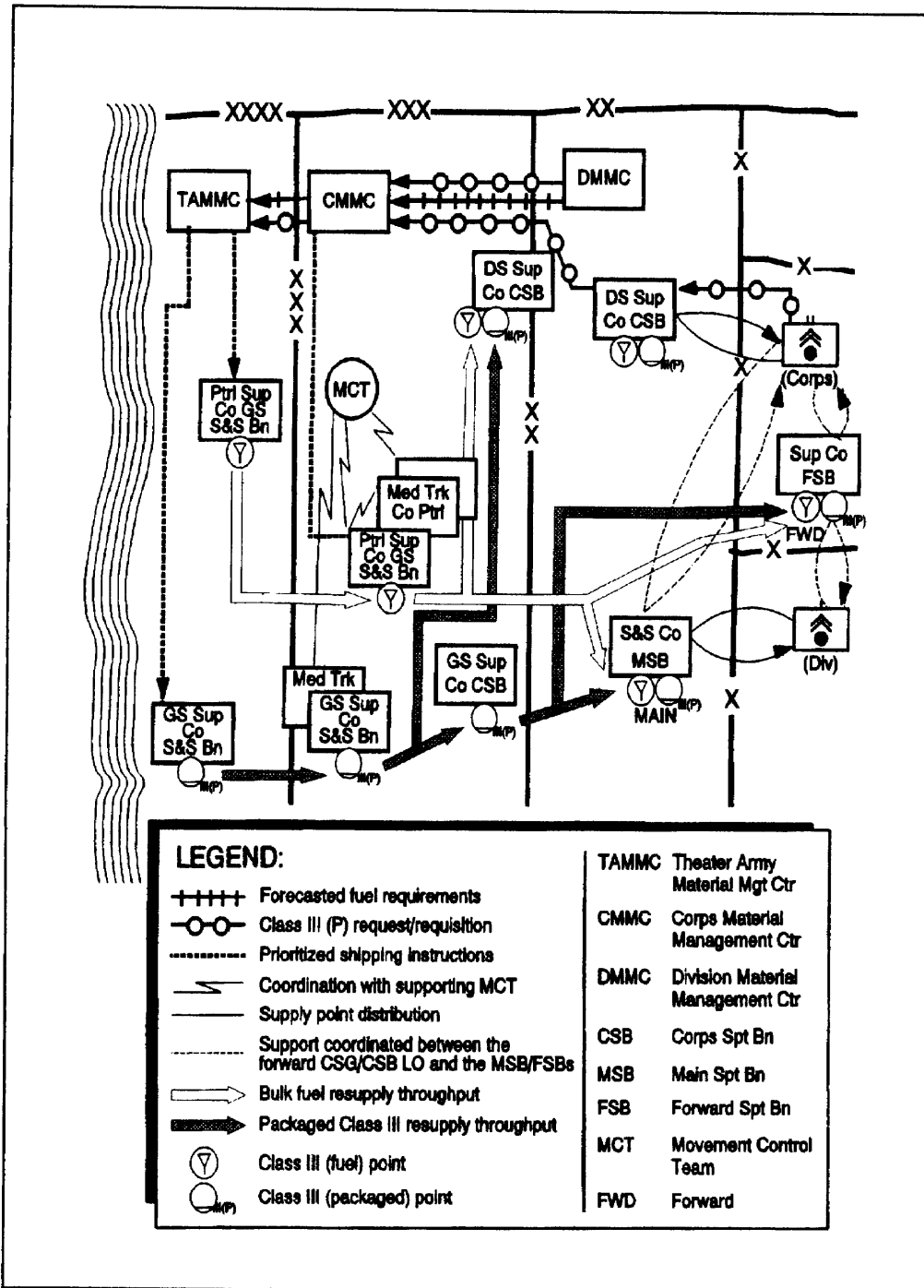

Figure 6-4. Fueling.

**Section VI  
MOVING**

Soldiers, equipment, and supplies must move rapidly and in sufficient quantities to support combat operations. Tactical actions require timely concentration of units and materiel and often demand short-notice movement of large forces and major shifts in direction of movement. Automated systems provide in transit visibility. At the tactical level, units, supplies, and important facilities move as battles progress to ensure responsive support of committed units as large as corps. While moving, CSS units must protect themselves and provide logistical support to combat units. Planning, controlling, and executing transportation operations require detailed preparation and extensive training of CSS staffs and units. The complicating effects of terrain, weather, and enemy interdiction demand well-planned engineer support and

great flexibility of transportation planners and operators (see Figure 6-5).

MLRS units have limited haul capability when uploaded with organic equipment and ammunition basic load. Additional transportation may be required to supplement the battalion and battery resources. It may be used for such tasks as hauling additional Class III and Class V supplies, moving large amounts of barrier materials, evacuating damaged material, and making administrative moves. Units should consider the use of HETs when conducting long moves. Requests are forwarded by the S4 or supply sergeant through logistics channels to the DISCOM or COSCOM movement control center (MCC). Aerial transport is discussed in Appendix A.

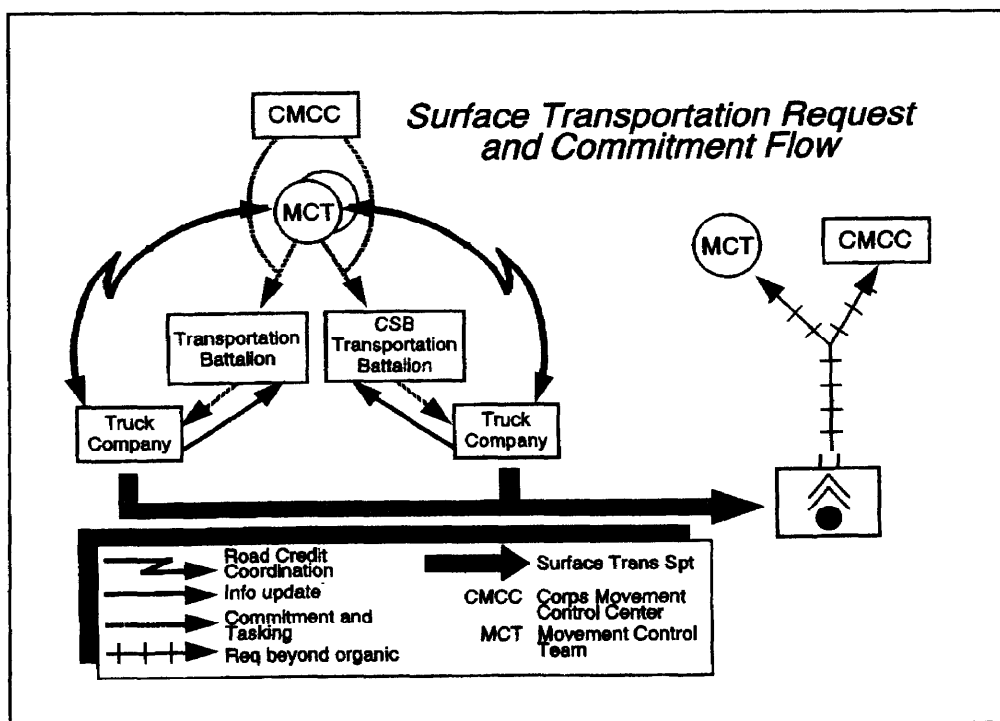

**Figure 6-5. Surface transportation request and commitment flow.**

---

Section VII  
**SUSTAINING SOLDIERS AND THEIR SYSTEMS**

---

The five elements to sustaining soldiers and their systems are personnel services, health services, field services, quality of life, and general supply support (FM 100-5).

---

### Personnel Service Support

*Personnel service support is the management and execution of personnel services, resource management, finance services, and legal service support. Soldiers are reassured by concerned, positive leadership and a personnel system that ensures care for them while they perform their missions (FM 100-5).*

Personnel service support is an important component of CSS. It involves many CSS functions that sustain the combat potential of the force and the morale and welfare of the soldier. It includes the following:

- Personnel services (see also Section III, Manning).
- Finance support.
- Chaplain activities.
- Legal service support.
- Public affairs.

#### Personnel Services

In addition to the three combat critical tasks found in the Manning function at Section III, personnel services include routine administration, awards, promotions, efficiency reports, etc.

In the MLRS battalion, the staff officer responsible for coordinating personnel service support is the S1. In the divisional MLRS battery, the 1SG and unit clerk are the focal points for personnel service support activities.

#### Finance Services

Finance services to the battalion are usually provided by mobile pay teams (MPTs) from the corps area finance support unit. During combat operations, the MPTs make payments to soldiers in amounts established by the theater

army commander or in lesser amounts if the soldier so desires. When and where the soldier is paid are determined by the commander and coordinated by the S1.

#### Legal Service Support

Legal services support is coordinated by the S1 section. It is provided to the battalion on a GS basis by the staff judge advocate of the division. It includes the following:

- Legal advice to commanders on all matters involving military law, domestic law, foreign law, international law, and administrative proceedings.
- Representation to soldiers accused and/or suspected in military justice matters and to personnel pending adverse military personnel action.
- Advice to soldiers on complaints, reports of survey, and the right to silence in administrative proceedings.
- Legal assistance to soldiers on personal civil legal matters.

### Health Service Support

*The health service support (HSS) provides flexible, versatile, and fully modernized HSS units to support the rapid deployment of a CONUS-based, force-projection army. The medical force will assure a medical presence with the soldier and, at the same time, provide state-of-the-art medical and surgical treatment and evacuation, limited only by the operational movement. This support will ensure that battlefield casualties are treated and evacuated quickly (FM 100-5).*

The basic health service mission is to preserve the fighting strength. Health service support involves the prevention of illness through field sanitation and personal hygiene. It also involves obtaining medical support that ranges from sick call (conducted by battery aidmen) to the processing



of casualties. Carrying out this mission requires the implementation of a full array of services. Some services are as follows:

- Hospitalization.
- Evacuation.
- Dental support.
- Veterinary and preventive medicine activities.
- Medical supply and maintenance.
- Optical support.
- Laboratory support
- Command and control.

### **Battalion-Level Support**

The battalion treatment team can provide limited medical services (administer first aid, give emergency treatment to patients who must be evacuated, and handle deceased personnel). The section is supervised by a physician's assistant. It operates a clearing station and provides medical treatment for the battalion headquarters.

The battalion aid station is normally located with the battalion trains. Ambulance support is provided by the ambulance team (one vehicle). Given the limitations of one ambulance and the likely dispersion of the firing batteries, the battery commanders and platoon leaders should designate a vehicle to be used for casualty evacuation to the battalion aid station.

### **Battery-Level Support**

At the battery level, the combat medics provide medical support to the unit. They are at the lowest level on the medical support chain. They are generally limited in the amount and types of care they can give the patients. Care is limited to treating minor injuries and reducing the effects of serious wounds. They rely on the battery for evacuation support.

In the divisional MLRS battery, there are three organic combat medics. They can provide limited medical services (first aid and emergency treatment to patients who must be evacuated). Additional medical support is provided by medical companies from the DISCOM.

In the nondivisional MLRS battery, medical support is provided by the battalion combat medic section.

### **Evacuation**

Evacuation from the unit is mainly the responsibility of the unit. Units are required to evacuate their personnel to ambulance exchange points or supporting field hospitals. However, the medical companies supporting the MLRS unit can evacuate casualties. Evacuation by using medical company support is done through coordinated or previously established channels to the designated clearing station or combat zone hospital. Beyond that, medical companies are responsible for the evacuation of the patients if care is required beyond the capability of the treatment facility.

Air evacuation support is available to the corps. This support is provided by the aeromedical company from the corps aviation brigade. The external SOP of the supporting unit should be consulted for the procedures to request aeromedical support.

### **Class VIII: Medical Supplies**

Medical supplies are obtained through medical channels. Items required by a battalion aid station are requisitioned by the primary care physician through the supporting medical unit. Nondivisional MLRS units under corps control are supported by the medical battalion located in the communications zone (COMMZ). Class VIII supplies for the divisional MLRS units are requisitioned from the MSB medical company.

### **Field Service Support**

*Field services consist of food preparation, water purification, bakery, clothing and light textile repair, laundry and shower, parachute packing, air item maintenance, rigging supplies and equipment for airdrop, and mortuary affairs. Technological advances have improved the quality of field service support to the soldier from tactical showers to improved food service support from modular field kitchens. Provision of these basics is essential for the maintenance of soldier health, morale, and welfare (FM 100-5).*

Services in the division, particularly in the forward areas, are limited. They are provided by the S&S company of the MSB with corps augmentation (see Figure 6-6, page 6-20).

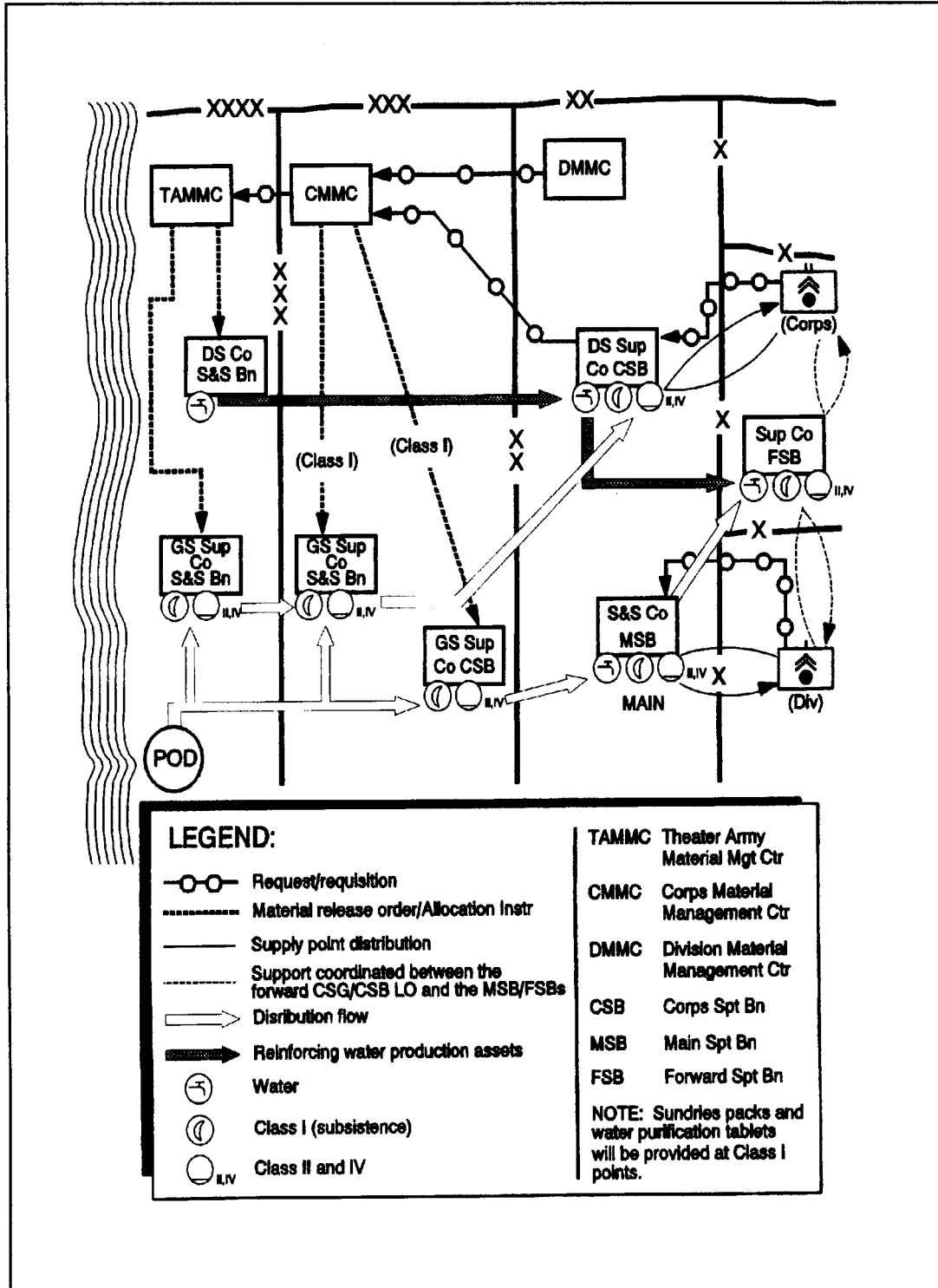

Figure 6-6. Sustaining soldiers and their systems.

## Class 1: Subsistence

Subsistence is provided through forward distribution points to combat units of the division. Corps supply and service (S&S) battalions operate COSCOM distribution points in the COMMZ. The supply and service (S&S) company of the MSB operates the distribution points at the DSA. Strength reports and any special requirements serve as the basis for computing Class I requirements.

Supplies are requisitioned through the proper logistics support unit at the support area. Unit distribution of Class I to the division is broken down into battalion lots in the DSA. Supplies are now picked up by the unit at the prescribed forward distribution point. Class VI supplies are issued with Class I supplies.

The MLRS units submit their requests directly to the supply unit operating the forward distribution point of the COSCOM or DSA, as appropriate.

### Shower, Laundry, and Clothing Repair

Shower, laundry, and clothing repair are provided by the field service company (FSC). The FSC is the provider of tactical services to divisional and nondivisional units from the corps forward area to the FLOT.

### Mortuary Affairs

Units are responsible for the search, recovery identification, care and evacuation of remains to the nearest collection site where mortuary affairs personnel will operate the initial collection point.

Temporary burial by the unit is approved only when evacuation of remains is not possible. All remains temporarily interred will be recovered as soon as the situation permits and evacuated to the nearest collection point or mortuary.

## Quality of Life

*Ensuring quality of life is a command responsibility. Quality of life and family considerations affect every soldier's readiness and willingness to fight. Effective personnel services, health services, and field services ease immediate soldier concerns. The soldier who fights best is the one who is reassured that his loved ones are adequately cared for at the home station, especially when units deploy from forward-presence locations. The family supports the soldier best when it is assured that the soldier is appropriately cared for. Accurate and timely delivery of mail enhances the quality of life of the soldier in the field. Command information provided to family members must be as timely as possible, especially in an age of instant communications where a soldier's friend may be sharing news about a loved one in almost real time. A direct relationship exists between adequate, well-thought-out soldier morale, and combat effectiveness (FM 100-5).*

### Postal Services

A postal element, assigned by the corps DS postal company, receives and separates mail by battalion and then turns it over to the brigade S1. The battalion mail clerk receives and sorts the mail by task organization. He distributes/delivers it to the certified unit mail handler.

### Class VI: Personal Demand Items

Class VI supplies consist mainly of Army and Air Force Exchange Service (AAFES) items. Examples are toilet articles, tobacco, and confections. The Class VI system becomes operational when the exchange operation becomes non operational. The request for Class VI supplies is submitted with the request for Class I. Class VI supplies are picked up with Class I resupply.

### Command Information

Maintaining ties with home is essential to sustaining the morale of our soldiers. Unit commanders should consider publishing and distributing newsletters to keep families in touch with the activities of deployed soldiers as well as arranging for local newspapers to be delivered for circulation within the unit.

## FM 6-60

### Morale, Welfare and Recreation

Soldiers require the opportunity to relax and maintain an adequate level of physical fitness. Without these opportunities, the mental toughness and endurance required to fight and win stand to be degraded. Unit commanders, assisted by the Bn staff, can address these needs through actions like deploying sports equipment, coordinating for library material, etc.

### Chaplain Activities

Chaplain activities are provided by the unit ministry team (one chaplain and one chaplain's assistant) operating from the combat trains. This team is dedicated to serving the spiritual needs of soldiers. The activities of the chaplain are coordinated through the S1 and are published in paragraph 4 of the FA support plan. Chaplain activities include the following:

- Providing worship opportunities.
- Administering sacraments, rites, and ordinances.
- Providing pastoral care and counseling.
- Advising the commander and staff on matters of religion, morals, and morale.
- Ministering to those suffering battle fatigue.
- Providing religious support to enhance soldier morale and unit cohesion.
- Routinely visiting unit soldiers in nearby hospitals.

### General Supply Support

*General supply support encompasses the provision of clothing, water, barrier material, and major end items in support of the force. These classes of supply include all the systems that support the soldier. The quality and acceptability of rations, clothing, and sundry packages are critical in sustaining the morale of soldiers, enhancing their ability to perform effectively (FM 100-5).*

### Class II: Clothing and Organizational Equipment

This class applies to all supplies and equipment other than principal items and cryptographic equipment prescribed by TOE, common tables of allowances (CTAs), and PLLs. Class II supplies include clothing, individual equipment, tool sets, administrative supplies, tentage, and housekeeping supplies.

Class II supply requests are made through the supporting supply unit at the logistics support area. The unit draws its Class II resupply from the logistics support area supporting the unit.

### Class IV: Barrier/Fortification and Construction Materials

This class of supplies includes barrier, construction, or fortification material and the lightweight camouflage support system. Some Class IV items are regulated through command channels. Requisitions for regulated Class IV items (normally, fortification and barrier material) are submitted through command channels. Items not regulated, such as small quantities of nails and common electrical, plumbing, and similar hardware, are requested or obtained from the supporting logistics unit.

The battery supply section picks up the Class IV items from the Class IV forward distribution point located in the support area. In some cases, corps or division may deliver requested critical items directly to the unit.

### Class VII: Major End Items

The issuing of major end items (launchers and HEMTTs) is closely controlled through command channels. The commander issues priorities for the replacement of losses. He considers item availability, unit mission, and the tactical situation.

Requests for major end items normally are processed in the form of battle damage reports. These reports are consolidated at command level and processed through command channels. Requests for controlled non battle loss items are submitted through command channels. Requests for issue are approved by the maneuver commander. Major end items of equipment may be delivered to the unit, or the unit may have to pick up the items from a designated support unit.

**Class X: Nonstandard Items**

Nonstandard supplies are items intended for support of nonmilitary programs. They include agriculture, food, clothing, and medical supplies and economic development items if resources of the area are inadequate. Class X supply is handled through civil affairs units. These units estimate requirements and supervise the distribution of supplies.

**Other Supplies**

Stocks of unclassified maps are maintained for the division by the S&S company of the MSB. For units under corps control, they are maintained by a designated S&S company. The S4 requests unclassified maps through Class II channels on the basis of requirements established by the S2.

The S&S company of the MSB purifies and distributes water. It normally establishes water points in the BSAs, DSAs, and COMMZ.

---

**Section VIII**
**OTHER CSS RELATED FUNCTIONS****Enemy Prisoners of War**

The S1 plans and coordinates EPW operations, collection points, and evacuation procedures. EPWs are evacuated from the battalion area as rapidly as possible. The capturing battery is responsible for the following:

- Guarding prisoners until relieved by proper authority.
- Recovering weapons and equipment.
- Removing documents with intelligence value.
- Reporting to the TOC and ALOC.

Prisoners may be evacuated to the vicinity of the ALOC or UMCP for processing and initial interrogation. Crews of vehicles undergoing repair or unoccupied mechanics act as guards. Prisoners are then moved to the brigade EPW collection point on returning logistics vehicles or by transportation coordinated by the S4. As necessary, the S2 reviews and reports any documents or information of immediate value. The S4 coordinates evacuation of large amounts of enemy equipment. Wounded prisoners are treated through normal medical channels but are kept separated from US and allied patients. For additional information on treatment and handling of EPWs, see FM 27-10.

**Decontamination Operations**

Thorough NBC decontamination for personnel and equipment is performed by the division or corps decontamination unit with support from the contaminated unit. The decontamination unit will provide specialized equipment and expertise. Priorities for decontamination are established by higher headquarters. Therefore,

decontamination support may not be immediately available. This support is coordinated through the FA brigade HQ for MLRS battalions in a FA brigade, through corps artillery HQ for MLRS battalions under corps control, and through the div arty HQ for the divisional MLRS battery.

Operational decontamination is performed by the HHS battery or the firing battery HQ section. This operation requires the use of the M17 Sanator (available in the HQ section of divisional batteries or the HHS of the MLRS battalion).

**Reconstitution**

Planners must be prepared for mass casualties, mass destruction of equipment, and the destruction or loss of effectiveness of entire units. Battalion units that have been catastrophically depleted or rendered ineffective are returned to combat effectiveness through reconstitution.

Commanders reconstitute by either reorganization or regeneration. The intensive nature of regeneration requires that a unit be pulled out of combat and is therefore not a Bn commander's prerogative (see FM 100-10).

**Reorganization**

Reorganization is the action taken to shift resources within a degraded unit to increase its combat power. Measures taken include the following:

- Cross-leveling equipment and personnel.
- Matching operational weapon systems with crews.
- Forming composite units.

**Immediate battlefield reorganization** is the quick and often temporary restoration of units conducted during an operation.

**Deliberate reorganization** is a permanent restructuring of the unit. Deliberate reorganization is supported with higher echelon resources and must be approved by the parent-unit commander one echelon higher than that reorganized.

### Weapon System Replacement Operations

Weapon system replacement operations (WSRO) is a method to supply the combat commander with fully operational replacement weapon systems. Three terms which are often used in describing WSRO are discussed below (see Figure 6-7).

- A **ready-for-issue weapon** is a weapon that is mechanically operable according to current standards

and has all ancillary equipment (fire control, machine guns, radio mounts, and radios) installed. The vehicle has been fully fueled, and basic issue items are on board in boxes. There is no ammunition on board, and the gaining unit must provide the crew.

- A **ready-to-fight weapon system** is a crewed, ready-for-issue weapon with ammunition stored on board. The weapon has been boresighted, and boresight has been verified.
- **Linkup** is the process of joining a ready-for-issue weapon with a trained crew.

WSRO is simply a procedure for bringing a weapon system to a ready-to-fight condition and handing it off to the combat unit. It involves making a vehicle ready to issue and marrying it to a complete crew, which makes it ready to fight. WSRO is an intensively managed process for giving the commander usable weapon systems in the shortest possible time.

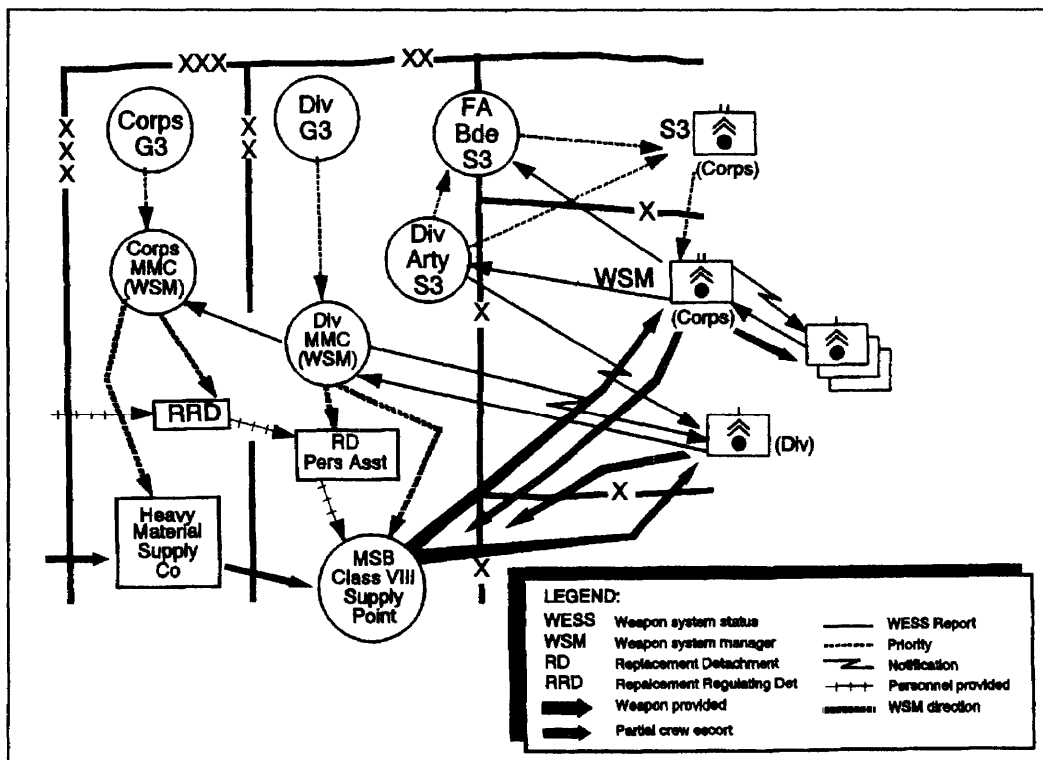

Figure 6-7. Weapon system replacement.

---

Section IX  
**Logistics Operations with the Marine Corps**

---

**There are some fundamental differences between the services in their approach to logistics. The MEF has a force service support group (FSSG) of eight battalions which are task organized based on the missions. The MEF normally conducts operations within 50 miles of its support base which is generally established around a major sea port or air-head. The FSSG is resourced to support all classes of supply and deploys with 60 days of sustainability. The FSSG will support the ground combat element (GCE) via a smaller mobile combat service support element (CSSE) that will provide direct support and remain close to the GCE.**

---

### Army

Corps MLRS battalions are supplemented with attached MSTs for intermediate DS (third echelon) vehicle, fire control, and communications maintenance.

MLRS units normally deploy with a 15-day package of supplies. They will receive a supplemental PLL/ASL stockage that equates to the support package of the MAGTF prior to, or during, deployment.

MLRS units have organic ammunition resupply vehicles. They will retain responsibility for ammunition resupply from the supporting CSSE forward to the firing units. Excessive distances (80+km) between the firing units and the CSSE will adversely impact on operations by reducing the resupply rate. This will ultimately result in a logistically driven reduction in the rate at which an MLRS unit can engage targets.

### Marine Corps

The USMC will provide classes of supply I, II, III, IV, VI, VII (common only), and VIII. Additionally, they will requisition and position MLRS ammunition (both rockets and missiles) at the FSSG, and provide all small arms Class V at the forward ASP. Similarly, the MAGTF will process class IX requests from the MLRS unit and its attached MSTs for replenishment of PLL/ASL. The MAGTF will provide overflow DS maintenance, some GS maintenance support, and responsibility for retrograde of all depot level repairable to the appropriate depot level agency (see Figure 6-8, page 6-26).

The supply system is a Department of Defense (DOD) system and should not have a significant impact. The challenge is the incompatibility of the Army unit level logistics system ULLS) and the USMC asset tracking for logistics and supply system (ATLASS). There will be a need for Army MLRS units to manually enter PLL/ASL replenishment part requisition statuses into the ULLS, based on manual feedback from the supporting FSSE. Similarly, Army MLRS units will need to submit manual requisitions using USMC forms to the supporting FSSE so that they can enter the requisition into ATLASS. This can be facilitated by MLRS logistics liaison at the FSSE.

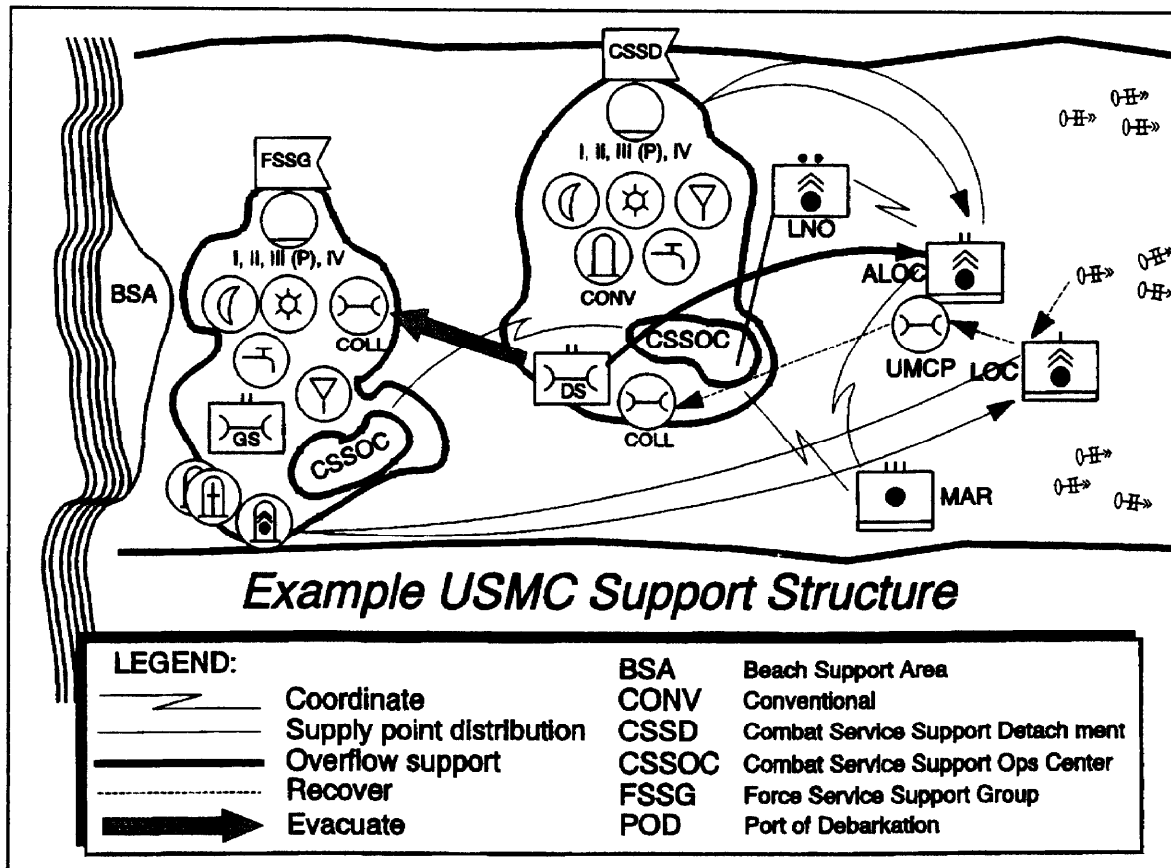

Figure 6-8. USMC support structure.



## CHAPTER 7

## MLRS COMMUNICATIONS

One of the six basic tasks of the field artillery battalion is to communicate. The ability of MLRS units to provide fires depends on a responsive, dependable communications system. The MLRS units must be prepared to rely on voice and/or data radio communications, usually over long distances, with many diverse and highly mobile units.

### Requirements

A communications system must satisfy one or more of the following requirements, but it may not necessarily satisfy them all:

- **Reliability** is the ability to function with the desired accuracy and dependability at all times. Elements of a reliable system are robustness, resiliency, and a sufficient capacity to meet all communications requirements.
- **Flexibility** is the ability to support widely dispersed forces under adverse conditions. Some indicators of a flexible system are multimeans, multiaxis (more than one line or net), mobility (to move with the supported force), and modular construction for ease of repair and replacement.
- **Security** is the ability to protect messages from unauthorized exposure and usage. Also, security is protection to the user from exposure to electronic warfare.
- **Speed** of the system must be sufficient to ensure timeliness of the message.
- **Economy** ensures timely communications with a minimum amount of personnel and equipment.

When planning communications systems, consider both internal and external requirements to communicate:

- **Internal** communications requirements include the facilities for control and coordination of the activities of the unit. The installation and maintenance of internal communications systems are the responsibility of the unit commander. In a higher headquarters, such as a battalion or division, the internal communications system serves as part of the external communications system of the subordinate unit.

- **External** communications requirements include the facilities by which a unit maintains communication with its next higher headquarters, adjacent units (as required), and supported or reinforced units. These allow the unit to receive data and information necessary to do its mission. The commander of any unit is responsible for the integration of his communications assets into the communications system of the next higher headquarters.

### Means

Communications systems differ according to the various means of communication--messenger, visual, sound, radio, and wire.

The communications means in a unit depend on the personnel, equipment, and transportation provided by the MTOE. The various means of communication have different capabilities and limitations. The means employed in any situation are generally those that provide the reliability, flexibility, security, and speed that meet or exceed the minimum required by the situation. Means should be employed so that they complement each other to provide the flexibility needed for communicating. Reliable communication can be greatly increased by using all the means available.

### Messenger System

Messenger systems are the most flexible, reliable, and secure of the communications systems. There is no formal messenger service at the corps or division level. When messenger service is required, the signal office is responsible for determining routes and schedules. The G3 is responsible for tasking the units for vehicles and personnel. Below division level internal courier systems can be established with organic assets.

### Visual and Sound Systems

Visual and sound systems have similar advantages and disadvantages. They are used extensively in almost all

## FM 6-60

situations and are readily available to everyone. They must be preplanned and coordinated to ensure comprehension. Advantages include a limited electronic signature in creating either visual or sound signals. They do not emit radio frequency (RF) signals, so EW is not a threat. Disadvantages are the noise, confusion, dust, and smoke of the battle, which can obscure many of the signals. Also, enemy forces can mimic and deceive by the use of similar signals. Signal operation instructions include a section that lists some visual and sound signals. SOPs list the remainder for a specific unit operation.

### Radio System

Radio has advantages when compared to the other means. It does not require a physical link; therefore, radio transmissions can span great distances very quickly. It is easily installed and requires a minimum of manpower to operate. When required, it can be remoted away from operations centers, retransmitted to achieve even greater distances, and combined with wire systems as a result of net radio interface (NRI) to allow commanders to communicate over wire and radio. Another advantage - the ability to scramble our transmissions - while providing security, may lead to a disadvantage. When conversations cannot be overheard, operators tend to talk too long and too often, which can make the unit susceptible to enemy electronic warfare. Radio direction finding can target the transmitter; and interference, jamming, and intrusion can render radio communication relatively useless. Radio is also susceptible to co-site interference (antennas located too close to one another); mutual interference (bleed-over caused by radios operating on adjacent frequencies); and electronic noise created by placing antennas near power lines, generators, and other emitters such as radar and microwave sites.

### Wire System

Wire also has advantages when compared to the other means. It is more secure than radio, visual, and sound systems; but it is never to be considered completely secure without cryptographic devices. Wire systems are not particularly vulnerable to EW, but they are extremely susceptible to damage from enemy artillery and our own tracked vehicles. Because of its limited vulnerability to EW, wire is almost always the system of choice in a defensive operation. It is also valuable in offensive operations when the situation and time permit its installation. Surprise may be obtained by using a wire system in preference to radio to prevent giving away positions. While wire systems have some distinct advantages over radio, they also have offsetting disadvantages. They are not mobile, with the exception of

the mobile stations in the MSE system. They must be carefully planned before installation. Their installation requires more time, personnel, and equipment than the other systems. While they are mostly secure, they can be tapped. Not all taps require a physical connection to the wire.

## Responsibilities

General responsibilities for communication are discussed below.

### Echelons of Command

The senior unit is responsible for establishing communication with its subordinate units, whether organic or attached. This responsibility is primarily one of planning and directing the establishment of the linking communications systems, since assets belonging to either the senior headquarters or the subordinate unit may be used (senior-to-subordinate relationship).

### Tactical Missions

Each of the four standard tactical missions has an inherent communications responsibility. (See Chapter 3.)

### Battle Area

Adjacent commands must maintain communication with each other to ensure coordination of the combat effort. The command on the left establishes communication with the command on its right as facing the forward edge of the battle area (FEBA) or FLOT (left-to-right relationship).

### Joint Maintenance

Regardless of which unit is responsible for establishing communication, all units served by the system must help restore any communications system disruption.

## Staff Responsibilities

Individual responsibilities for the communications system are discussed below.

### Commander

The commander is responsible for the adequacy and proper use of the communications system within his command. He is also responsible for its efficient operation in the system of the next higher command. The authority to establish, maintain, control, and coordinate the various communications means within the command may

be exercised by a subordinate in the name of the commander when such authority is properly delegated.

### **Battalion S3**

The S3 establishes priorities for communication in support of tactical operations. In coordination with the battalion signal officer, the S3 selects the general locations of the command posts and affiliated installations with communication as a major consideration. The rest of the staff submits requirements to the S3 for signal communication.

### **Battalion S2**

The S2 assesses the enemy's capability to interfere with signal communication. He is also responsible for the counterintelligence aspects of signal operations within the battalion.

### **Battalion Signal Officer**

The BSO works under the staff supervision of the S3 but is directly responsible to the commander for the battalion communications systems. The BSO advises the commander and staff on electronic counter-countermeasures (ECCM), signals security, communications training, communications planning, and selection of CP sites from a communications standpoint. He prepares the command and signal paragraph of the FA support plan. He coordinates with signal units for communications support. He supervises the communications activities in the battalion, to include the installation, operation, and maintenance of the battalion communications system and equipment. He is responsible for the COMSEC equipment and serves as the battalion COMSEC custodian for the unit. He issues and accounts for COMSEC equipment, key lists, codes, ciphers, SOI, and authentication systems.

## **Planning Considerations**

### **Plans**

The communications plan is designed to fulfill the requirements of a tactical mission. Planners use communications responsibilities, communications requirements, and the unit TOE (which provides the communications means) to produce a standardized system. To meet specific requirements, commanders may have to modify their systems on the basis of METT-T.

**Standard Radio Nets.** The field artillery uses a set of standard radio nets for all of the standard tactical missions.

This net standardization enables units to quickly and accurately interface in a combat environment. Standard net structures and purposes should not be arbitrarily changed except to tailor them to a modified mission. Such modifications should be kept to a minimum. Standard net structures (net titles, purposes, users, and equipment) are defined in this manual. They should be applied in unit SOP and kept current as changes occur.

**Voice and Data Nets.** The radio net architecture should change, depending on whether the unit has predominantly voice or data communication. MLRS battalions operate in nine internal voice nets (four for command and control, four for logistics coordination; and one for voice fire direction) and four internal FM data nets (three battery and one battalion fire direction). Additionally, the battalion operates on one internal Amplitude Modulated Very High Frequency (AM-VHF) for long range communications (voice or data). The battalion also operates on six external nets: two FM data, one FM C<sup>2</sup>, one FM ops/intel, one FM logistics, and one AM-SSB for Corps Arty Cmd or ops/fire. This architecture is designed to support a system that relies primarily on data communication. If data capability is lost by the battalion or by one or more of the batteries, the voice nets quickly become overburdened. Units must develop plans for converting some data nets to voice while continuing to support the remaining digital stations and for reconverting to data nets as that capability is restored. It is extremely important to keep voice traffic off data nets and vice versa, so a specific sequence for conversion must be developed for various contingencies. This procedure should be included in unit SOP and practiced during training.

**System Mixes.** The factors of METT-T affect the use of wire, visual, sound, and messenger systems to a greater extent than they do the radio nets. Any system or mixture of systems that will communicate the information with the least exposure to enemy EW and not place total reliance on radio is preferred. To describe any one system as "primary" is no longer appropriate.

**Electronic Counter-Countermeasures.** ECCM should be part of each battalion SOP. They can improve OPSEC and preserve communications. ECCM techniques that have been found to be effective include the following:

- Require authentication on nonsecure nets. Proper authentication procedures can eliminate intrusion and imitative deception.
- Do not mix plain and encrypted traffic on the same net. Doing so compromises the nature of the net,

## FM 6-60

which makes interception and analysis easier for the enemy.

- Use secure equipment whenever possible. If the battalion is supporting a unit without secure capability, specify nets that will be unsecured and enforce secure discipline on all remaining nets.
- Limit transmissions to less than five seconds. This makes interception and direction finding more difficult.
- Work through jamming if at all possible. Jumping nets should be a last resort. Remember that if jamming is bad enough to keep a unit from operating on a particular net, it will also keep many of the stations from receiving the signal to change frequencies. If antijam frequencies are to be used, they must be disseminated well in advance, so that subscriber stations can move to the alternate frequencies in sequence as communication becomes impossible on the primary frequency.
- Use only authorized call signs from the SOI, and change them on schedule.

### Operations

Communications operations must take advantage of all available techniques to facilitate accomplishment of the mission. Techniques such as remoting transmitters, radio retransmission, antenna multiplexer, and the use of directional antennas help the MLRS battalion to provide timely fires and to survive to fight again.

**Remote Transmitters.** Remoting transmitters allows for the separation of the RF emitter from the personnel and equipment of the CP or other critical facilities. Also, remoting radios allows the transmitter to be sited for optimized communication while allowing the user to position in locations better suited to survivability. Remoting also minimizes on-site or mutual interference while dissipating and reducing electronic signatures. For additional information on remoting, see FM 24-18.

**Retransmission.** Retrans operations may be used to extend the area of coverage of a specific radio net or to reduce the electronic signature of a position. By use of a retrans site, RF power output can be reduced at the CP or other location. Overall net ranges can be doubled by the effective use of retransmission.

Frequency modulated very high frequency (VHF) transmission distances are restricted by terrain and

obstacles. The siting of radio equipment is often critical. The following are helpful hints for using FM retransmission:

- As a minimum, make a map recon of the area of operation. Coordinate with the S2 and S3 during the planning phase.
- Analyze the terrain for optimum communications to support the scheme of maneuver.
- Select primary and alternate locations for retrans. Consider accessibility, defense, and logistical support.
- Arrange the timetable for site occupation and net operation. Don't wait until a retrans vehicle is needed before sending it out.
- Ensure operators are well trained. They must be able to provide manual relay if they have equipment failures.
- Ensure operators are aware of the tactical situation.
- Ensure users understand how retrans works.
- If retransmitting data traffic, program additional key and/or delay time to allow radios to key up.

**Note:** Additional information on retransmission operations is in FM 24-18.

**Antenna Multiplexer.** Using antenna multiplexer, such as the TD- 1288 or TD- 1289, reduces the number of ground plane antennas required to operate multiple radios. The time required to align and tune these devices is considerably less than the time required to install multiple antennas. More information on antenna multiplexer is in TM 11-5820-880-12.

**Directional Antennas.** Directional antennas reduce electronic signatures in two directions while extending the range of the radio along the long axis of the antenna. Techniques concerning antenna construction and siting are included in ECAC-CR-83-200.

**Reestablishment.** Communication is essential to providing fire support. If communication with a station is lost, everything possible must be done to reestablish the link. The operator should--

- Troubleshoot the radio.
- Erect omnidirectional or unidirectional antennas.

Data nets are backed up by voice nets and vice versa. If data communication is lost, resolve the problem on the voice net. Unit SOP must prescribe exact actions to be taken to reestablish communication, and all personnel must be intimately familiar with those actions.

**Communications Planning Ranges**

Table 7-1 below can be used in communications planning. The ranges presented here were determined under ideal conditions; weather and terrain may have drastic degrading influences.

**Table 7-1. Communications Planning Ranges**

SYSTEM	POWER OUTPUT	VOICE RANGE	DATA COMMUNICATIONS	
			BAUD RATE	RANGE
RT-841	4 W	8 km		
RT-524/ RT-246	8 W 35 W	8 km 40 km	600-2,400 bps 4,800 bps 16,000 bps	22 km 19 km 9 km
RT-1439/ RT-1523	500 $\mu$ W 160 mW 4 W 50 W	400 m 5 km 10 km 40 km	600-2,400 bps 4,800 bps 16,000 bps	25 km 22 km 10 km
<p><b>Note:</b> bps = bits per second      mW = milli watts  <math>\mu</math>W = micro watts                  W = watts</p>				

**Communications Tips**

The following tips will help in establishing and operating a responsive and dependable communications system:

Do--

- Use the lowest power setting for effective transmission.
- Make transmissions as short as possible.
- Use proper radiotelephone procedures.
- Use the proper antenna (a directional antenna if possible).
- Use masking, if possible, to hide your signal.

- Use only authorized codes.
- Remote radios if possible.
- Enforce net discipline.
- Authenticate.
- Try to work through jamming.
- Plan for the use of retrans.
- Keep radios aligned and tuned.

**Net Structures**

**MLRS Battalion**

**External Communications.** The battalion operates on five external FM and one AM radio nets to communicate by voice and data with higher headquarters. Two of the FM nets are for data communication and three are for voice communication (see Figure 7-1, page 7-6).

- **Force FA Cmd Net (VHF-FM)(V).** This secure net is the primary voice (V) command and control link between higher headquarters and the MLRS battalion.
- **Force FA Ops/F Net (VHF-FM)(D).** This secure net provides the data link between the battalion FDS and the controlling headquarters TACFIRE.
- **Force FA Admin/Log Net (VHF-FM)(V).** The battalion operates on this net to coordinate external logistics requirements and support.
- **Corps Arty Cmd (AM/SSB)(V) and Ops/F Nets (AM/SSB)(D).** These nets provide the battalion link to the corps headquarters. These nets share a single AM radio system. Its primary function is the corps arty cmd net. As required, the unit moves to the Ops/F net.
- **Force Ops/Intel (VHF-FM) (V).** This net provides the battalion operational and intelligence information regarding the current operations of the supported force.
- **Force FA Tgt Acq (VHF-FM) (D).** This net is used for data communication between the fire direction centers and attached target acquisition assets or sensor system down-links as part of TMD.

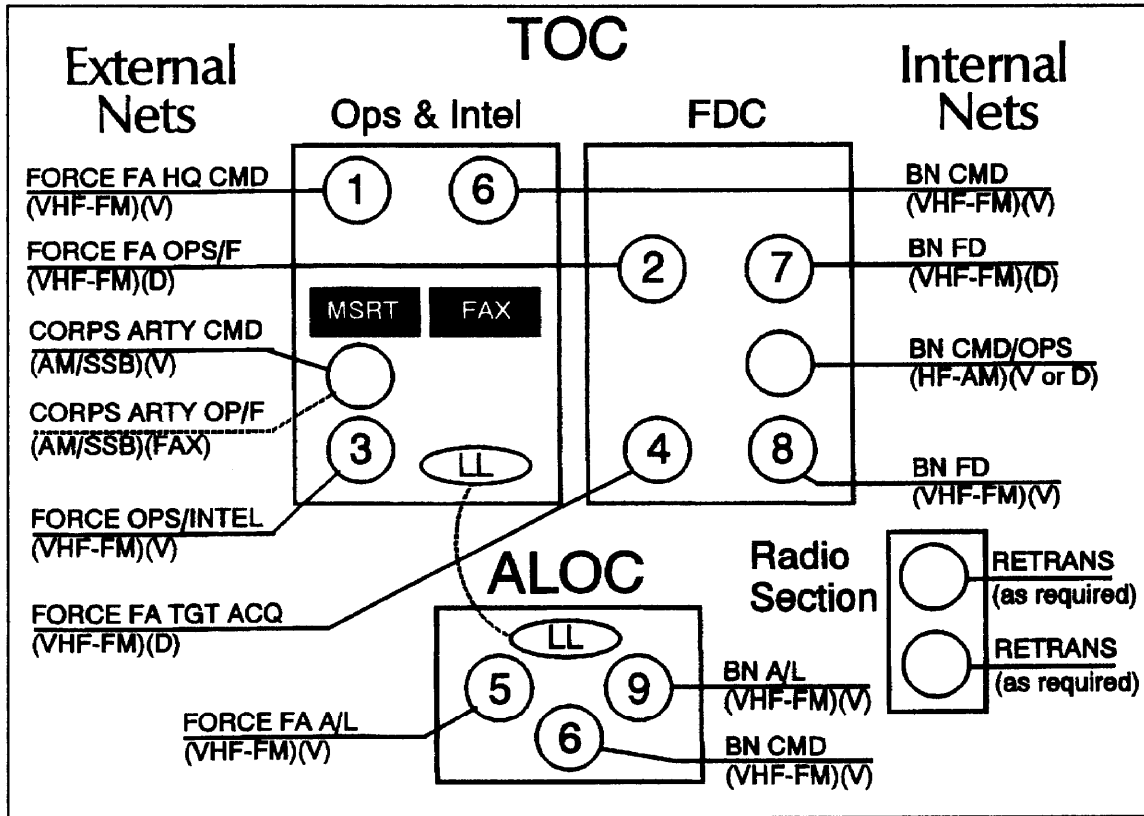

Figure 7-1. MLRS battalion net structure.

**Internal Communications.** The MLRS battalion communicates with the subordinate batteries mainly by secure FM voice and secure data means. Wire is used only within the HHS elements because of the position of the batteries and the limited quantity of wire. The battalion operates on four (4) internal FM radio nets (plus two nets dedicated to RETRANS) and one internal AM radio net to communicate with its firing batteries.

- Battalion Cmd Net (VHF-FM)(V).** This secure net is the main voice crud and control net used by the commander, his staff, subordinate commanders, and BOCs and as an alternate FD net. The NCS is the battalion operations section.
- Battalion Fire Direction-1 Net (VHF-FM)(D).** This secure net is used exclusively for data (D) communications between BOCs. No voice traffic should be used on this net. The NCS is the battalion FDC.
- Battalion Fire Direction-2 Net (VHF-FM) (V).** This secure net is exclusively for voice communications between fire direction centers. It facilitates planning, rehearsals, and execution and prevents this traffic from interfering with C<sup>2</sup> functions and data transmissions on other nets. Although this particular net may not be authorized for a specific unit in a given theater, it is imperative that these functions are allocated a net other than those allocated for C<sup>2</sup> and data communications functions.
- Battalion HF Cmd/Ops Net (HF-AM)(V or D).** This secure net facilitates secure long-range communications between the battalion FDC and the BOCs. This net uses an HF AM radio for voice or data communications with the batteries
- Battalion Admin/Log Net (VHF-FM)(V).** This secure net is used to reduce the amount of traffic on the cmd net. The NCS is the ALOC.

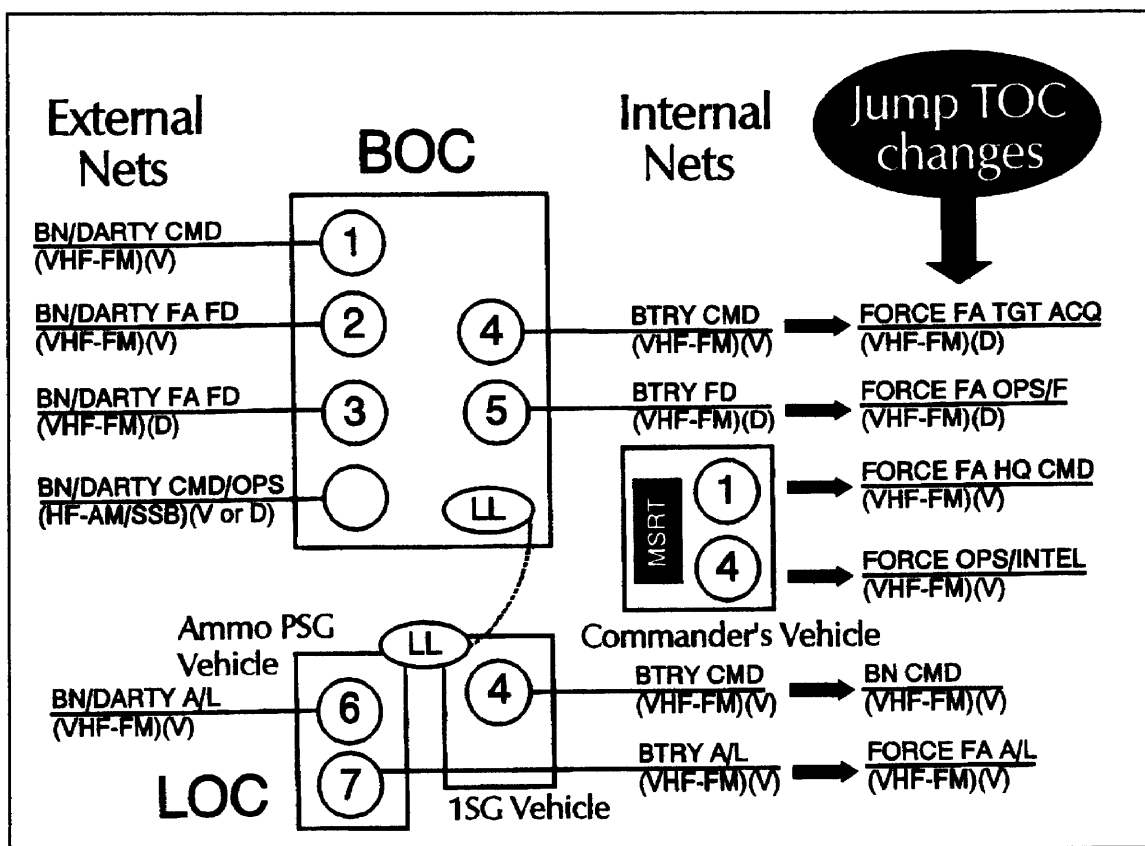

Figure 7-2. MLRS battery net structure.

## MLRS Battery

**External Communications.** As the main unit of MLRS employment, the firing battery is designed to operate as part of an MLRS battalion or independently, under the force FA headquarters. The battery operates on four external FM radio nets and one AM radio net to communicate by voice and data with higher headquarters. In a standard GS or GSR mission, the battery would operate on the force FA headquarters and/or the reinforced unit on these nets. If the battery has a standard R mission, the BOC enters the reinforced unit cmd net and the FD net. If the battery is given a nonstandard R mission, the FDC may enter the FD net of the reinforced unit and establish FM voice communications specified in the fire support plan (see Figure 7-2).

- **Controlling FA Headquarters (for example, div arty or MLRS bn) Cmd Net (VHF-FM)(V).** This secure net is the main command and control link between higher headquarters and the MLRS battery.
- **Controlling FA Headquarters Admin/Log Net (VHF-FM)(V).** This secure net is optional and is used to reduce the amount of traffic on the battalion net. It keeps administrative and logistical traffic from interfering with command and control transmission.
- **Controlling FA Headquarters Cmd/Ops Net (HF-AM/SSB)(V or D).** The battery can communicate by voice or data via an AM HF radio. This ability facilitates longer range communications with the controlling FA headquarters.
- **Controlling FA Headquarters FD-1 Net (VHF-FM)(D).** This secure net provides the data fire direction link between higher headquarters and the MLRS battery.
- **Controlling FA Headquarters FD-2 Net (VHF-FM)(V).** This secure net is exclusively for voice communications between fire direction centers. It facilitates planning, rehearsals, and execution and prevents this traffic from interfering with C<sup>2</sup> functions and data transmissions on other nets.

**Internal Communications.** The MLRS battery has three internal FM radio nets. Although the battery has no capability to lay external wire, internal wire lines can link elements within a position. However, communications usually are achieved through voice or data FM radio, rather than wire. The BOC is the NCS of both the battery and and battery FD nets. The LOC is the NCS of the A/L net.

- **Battery Cmd Net (VHF-FM)(V).** This secure net gives the battery commander his main voice communications and control link to his platoons. Each firing section monitors this net during normal operations. The firing sections may use it for voice-transmitted fire missions if data communications with the FDS are lost. Net discipline is essential. Short, mission-essential radio transmissions enhance survivability.
- **Battery FD Net (VHF-FM)(D).** This secure net is used only for fire mission processing and other data communications between the battery BOCs, POC, and launchers.

- **Battery Admin/Log Net (VHF-FM)(V).** This secure net is used to reduce the amount of traffic on the battery cmd net. It keeps administrative and logistical traffic, such as ammunition, recovery, and maintenance support, from interfering with command and control transmissions. All HEMTTs/HEMATs, maintenance, supply, and recovery vehicles operate on this net.

**MLRS Platoon**

Communications at platoon level are limited to FM (voice and data) radio. Each platoon headquarters has four secure FM radios in the armored CP carrier. They are used for the battery cmd net the **battery FD** data net, the **battalion FD** voice net, and the **Battery Admin/Log** net. If operating as a jump BOC, the platoon HQ can operate on all required nets except the HF-AM/SSB CMD/OPS net. An example of jump BOC radio configuration is at Figure 7-3.

Figures 7-3, page 7-9 and 7-4, page 7-10 are MLRS communications matrices.

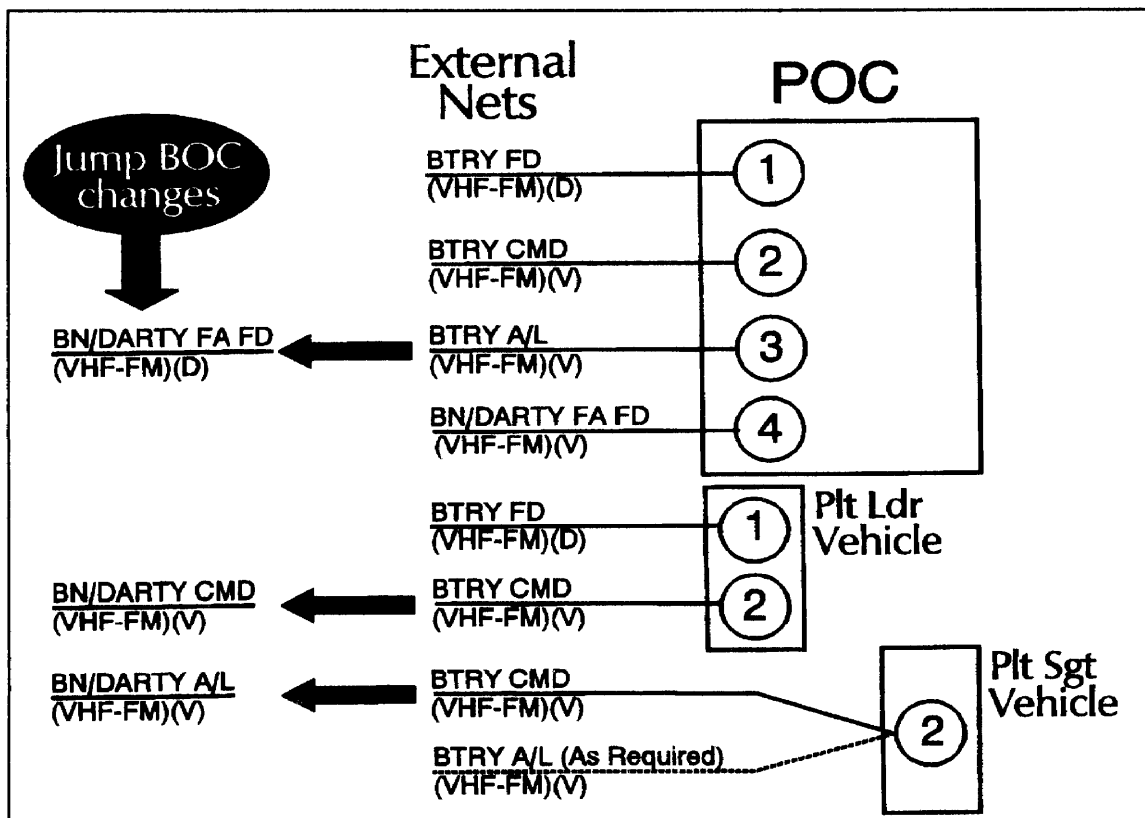

Figure 7-3. MLRS platoon net structure.



Corps MLRS Battalion Communications Network Matrix	INTERNAL							EXTERNAL							
	Bn Cmd (VHF-FM)(V)	Bn FD (VHF-FM)(D)	Bn FD (VHF-FM)(V)	Bn Cmd /Ops (HF-AM)(V or D)	Bn Admin/Log (VHF-FM)(V)	Btry Cmd (VHF-FM)(V)	Btry FD (VHF-FM)(D)	Btry Admin/Log (VHF-FM)(V)	Force FA Cmd (VHF-FM)(V)	Force FA Ops/F (VHF-FM)(D)	Force FA Admin/Log (VHF-FM)(V)	Corps Arty Cmd (HF-AM/SSB)(V-FAX)	Corps Arty Ops/F (HF-AM/SSB)(V-FAX)	Force Ops/Intel (VHF-FM)(V)	Force FA Tgt Acq (VHF-FM)(D)
Battalion Commander	X								X						
Battalion XO	X				X				A		A				
Battalion S3	X								X						
Battalion Ops and Intel Sections	N			N					X		X	A	X		
Battalion FDC		N	N							X					X
Battalion Supply (ALOC)					N						X				
Battalion Maintenance					X										
HHS Wrecker					X										
HHS Recovery					X										
Medical Treatment Team					X										
Ambulance Team					X										
Liaison Teams	X	X	A						A						
Battery Commanders	X	A				X									
BOCs	X	X	X	X		N	N	A							
Battery 1SGs (LOC)					A	X	X	X							
Ammunition Platoon HQ (LOC)					X	X	X	N							
Battery Maintenance								X							
Battery Wrecker								X							
Battery Recovery								X							
PADS Section						X									
Platoon Leaders						X	X	A							
Platoon Sergeants						X	X	A							
POCs			X			X	X	X							
Launchers			A			X	X	A							
HEMTTs/HEMATs								X							

LEGEND: A = As required N = Net Control Station X = Subscriber

Figure 7-4. Corps MLRS battalion communications network matrix.

Divisional MLRS Battery Communications Network Matrix	EXTERNAL					INTERNAL		
	Bn/Divarty Cmd (VHF-FM)(V)	Bn/Divarty FD (VHF-FM)(D)	Bn/Divarty FD (VHF-FM)(V)	Bn/Divarty Cmd /Ops (HF-AM)(V)	Bn/Divarty Admin/Log (VHF)	Btry Cmd (VHF-FM)(V)	Btry FD (VHF-FM)(D)	Btry Admin/Log (VHF-FM)(V)
Battery Commander	X	A				X		
BOC	X	X	X	X		N	N	A
Battery 1SG (LOC)					A	X		A
Ammunition Platoon HQ (LOC)					X			N
Battery Maintenance								X
Battery Wrecker								X
Battery Recovery								X
PADS Section						X		
Platoon Leaders						X	X	A
Platoon Sergeants						X		A
POCs			X			X	X	X
Launchers			A			X	X	A
HEMTTs/HEMATs								X

LEGEND: A = As required N = Net Control Station X = Subscriber

Figure 7-5. Divisional MLRS battery communications network matrix.

Each launcher has two secure FM radios. The launcher crew operates on both the **battery cmd** net and the **battery FD** net through the launcher FCS. The crew can communicate with the platoon headquarters and the BOC. The platoon leader and the platoon sergeant each have two secure FM radios mounted in their HMMWVs. The platoon leader normally operates on the **battery cmd** net and the **battery FD** net through the FED. The platoon sergeant normally operates on the **battery cmd** or the **Battery Admin/Log** net as required.

### Mobile Subscriber Equipment

The MSE system provides secured voice, data, and fax communications to the user, whether static or mobile. It is an area communications system extended by mobile telephone. The MSE can be used for data transmissions, however, its main purposes are for voice telephone and fax communications.

The division and corps signal units will establish the MSE system by positioning signal nodes throughout the division and corps area of operations. Small extension nodes (SENs) will be placed near maneuver brigade and div arty CPs and throughout the rear areas. The MLRS battalions access the MSE system either by wiring into the extension nodes or by using cellular-type radiotelephones through the signal nodes.

When in place, the MSE network works similar to a civilian telephone system. Subscribers are assigned individual telephone numbers, which can be dialed directly. Text and graphics can be transmitted in hard

copy via the fax capability of the system (see Figure 7-6). The MLRS battalion uses three key pieces of equipment when it operates in the MSE system. These are discussed below.

### Digital Nonsecure Voice Telephone (DNVT) TA-1035/U or TA-1042A/U

The DNVT is the conventional telephone of the MSE system. It must be wired into the J-1077/U junction box, which is located at the area signal node. The user is responsible for laying wire to the junction box. The MLRS battalion will have DNVTs in the CP, TOC, ALOC, with the chaplain, and at the firing batteries. The DNVTs cannot operate with the older wire telephones, such as the TA-312.

### Mobile Subscriber Radiotelephone Terminal (MSRT) AN/VRC-97

The MSRT is the mobile cellular telephone of the MSE network. It links into the MSE system through one of the remote access units (RAUs) positioned throughout the area of operations by the signal unit. The RAU picks up the signal from the MSRT and switches it into the nearest signal node. The MLRS battalion has seven MSRTs. They are mounted in the vehicles of the battalion commander, XO, S3, S4, and each firing battery commander. The battalion also has two stand-alone installation kits (SAIKs), which allow the battalion S3 MSRT to be dismantled for use in the TOC and the S4 MSRT to be dismantled for use in the ALOC.

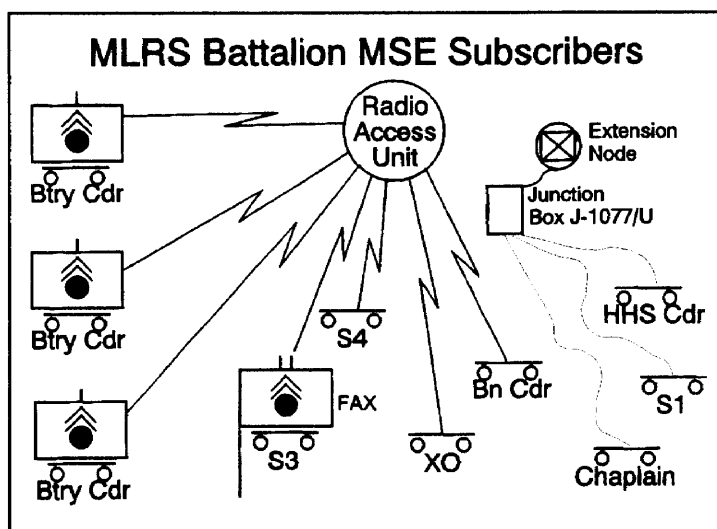

Figure 7-6. MSE subscribers.

## FM 6-60

### Lightweight Digital Facsimile (LDF) AN/UXC-7 or AN/UXC-7A

The LDF, when connected to the MSE system through the DNVT or DSVT, allows the battalion to send and receive text and graphics in hard copy. It can also be connected to the FM radios.

## Single Channel Ground and Airborne Radio System

### General

The AN/VRC-12 Series radios are being replaced by the SINCGARS family of radios. (See Table 7-2 below.)

**Table 7-2. SINCGARS Radios**

SINCGARS SYSTEM <sup>2</sup>	QTY R/T <sup>1</sup>	BACK PACK	PWR AMP
PRC-119 <sup>2</sup>	1	0	0
AN/VRC-87	1	0	0
AN/VRC-88	1	1	0
AN/VRC-89	2	0	1
AN/VRC-90	1	0	1
AN/VRC-91	2	1	1
AN/VRC-92	2	0	2

**Notes:** <sup>1</sup> RT-1439 W/O COMSEC  
RT-1523 W/Imbedded COMSEC  
<sup>2</sup> Systems using RT-1523 are identified with an additional "A" identifier (e.g., AN/VRC-92A)

The user of a SINCGARS radio must physically change the frequency. However frequencies can be stored which makes changing them (physically) much easier. The SINCGARS radio is more complicated to operate than the old VRC-12 series and requires more sustainment training for the operators to maintain proficiency. See FM 11-32 for defaulted information on SINCGARS.

### Data Communications

The MLRS FDS is limited to a data rate of 1200 bits per second (bps) and audio frequency shift keying (AFSK or FSK). For FDDMs, Version 10 software allows the operator to select data rates of 1200, 2400, 4800, 9600, or 16,000 bps on channel 5.

FSK is an analog method of transmitting data as a pair of tones: a 1200 Hz tone representing a "1" and a 2400 Hz tone representing a "0" (1300 and 2100 Hz tones are also used to be compatible with KY-57 crypto equipment). The modem in each TACFIRE device converts the data 0s and 1s to these tones which are then transmitted just as voice is over the radio. SINCGARS is a data radio system. It converts analog voice (as well as analog and data) to a binary data signal (a series of 1s and 0s) at 16,000 bits per second (bps) for transmission and converts the data signal back to an analog voice (or analog or data) signal upon reception. The SINCGARS uses a data rate adaptor (DRA) to handle data signals. When the DRA is fed data at a rate less than 16 Kbps, it uses the difference in time to send each bit (0 or 1) several times (e.g., at 1200 bps each bit is transmitted 13 times in the 16 Kbps signal). The receiving SINCGARS then uses a primitive form of error correction known as majority logic to determine the identity of the bits and convert the data back to the original data rate. With older radios (AN/VRC-12 generation), when the signal gets weak or distorted, known as a low signal to noise ratio (S/N ratio), the receiver simply amplifies the noise and the weak signal. A low S/N ratio with SINCGARS causes the bits to be lost or distorted. With analog voice transmissions, a large bit error rate (BER) can be tolerated (i.e., one bit in ten can be lost or confused and the signal can still be understood by the radio operator since the human ear is very forgiving). In data communications between computers, the BER must be less than one error in 1000. This is why it is possible to have good voice communications with SINCGARS and not be able to establish data communications. The following considerations will improve data communications using SINCGARS:

- Try to maintain a good radio line of sight (LOS) using higher antennas, and watching for intervening crests. Shorter ranges improve S/N ratio and lower the BER.
- Don't remote data nets unless essential for antenna siting. Because data transmissions are very short, they are hard for the enemy to detect using RDF.
- Use single channel mode. Frequency hop (FH) reduces range and reliability of data communications (max data rate for FH is 4800 bps).
- Use the best antenna available. A good antenna ground plan system improves output power. Directional antennas are also more efficient thus decreasing the S/N ratio and BER.
- If selectable, lower the data rate.

- Isolate and shield radio equipment from all other electronic or power generation equipment that may radiate energy and reduce the S/N ratio by increasing the noise level.
- Use lower frequencies to cut propagation path loss.

### **Antennas**

Poor communications or lack of communications can be caused by long distances between transmitter and receiver, unfavorable terrain, and other conditions. This problem can often be overcome by the use of the right antenna. When the tactical situation allows, the battalion FDC, the battery BOCs, and the POCs should use an extended-range antenna the OE-254/GRC, or the OE-303/GRC to obtain the maximum planning range of their radios.

To obtain the maximum efficiency of an antenna, the following factors must be considered:

- An antenna site should not be located in or near obstacles such as tunnels, overpasses, or steel bridges. They can block or reflect signals.
- Trees with heavy foliage and dense underbrush should be avoided as they can absorb signals.
- Antennas should not be set up near pole wire lines and high-tension power lines. They can introduce interference and absorb part of the radio signals. This also constitutes a safety hazard.

## APPENDIX A

**AERIAL TRANSPORT OF MLRS AMMUNITION AND EQUIPMENT****Aerial Ammunition Resupply**

Ammunition resupply of MLRS units is a critical operation. A technique or capability available to support resupply of the 5,005 pound LPC or the 4,609 pound GMLA is the use of the CH-47D helicopter. This appendix supplements the discussion of Class V operations in Chapter 6.

The CH-47D has a load-carrying capacity of 25,000 pounds. Loads can be carried internally or externally by using TOE equipment except for required external load slings.

**Internal Load**

The CH-47D can carry up to four LPCs or GMLAs internally for a total of 24 rockets or four missiles. Atmospheric or weather conditions in the area will dictate the load-carrying capacity of the CH-47D.

**Equipment.** The LPCs or GMLAs can be loaded by use of the following equipment:

- CH-47D on-board winch.
- Four (1,000) conveyor rollers, NSN 3910-0-903-1303.
- Twelve sheets of 3/4 inch plywood.

**Concept.** The LPCs or GMLAs can be loaded two at a time stacked on top of each other. They should be pre-positioned (by using the HEMTT crane) on top of conveyor rollers and one sheet of plywood. The on-board winch can then be used to pull the load into the aircraft. Plywood shoring should be placed down in the deck of the aircraft for the conveyor rollers to travel. The identical procedures are used to load the second two pods. Then all LPCs or GMLAs are tied down with standard 10,000-pound cargo straps.

**Off-Loading.** Four soldiers can push the load down the ramp and use the on-board winch to help brake the load.

**Loading Considerations.** The following should be considered:

- On- or off-loading requires about 30 minutes.
- A level landing zone is required to ensure the plywood shoring remains level.
- The winch should be hooked onto the aft end of the load to facilitate loading of the second LPCs or G/MLAs.

**External Load**

Current procedures permit only one LPC to be carried. Four 25 ton slings are required. The front two are 10 feet in length, and the rear two are 12 feet in length. Procedures to carry four LPCs will substantially expedite helicopter resupply when developed. The GMLA no-tolerance drop restrictions preclude external transport.

**Movement of Ammunition**

Aerial movement of MLRS ammunition is feasible and, given the limited assets of the COSCOM to move LPCs or GMLAs to the ASP, this is a potential solution. Availability of aircraft and the criticality of the mission will be the determinants in the execution of this operation.

**Transportation of MLRS Equipment on United States Air Force Aircraft**

The following procedures will aid MLRS units deploying by C141-B aircraft.

**M985 HEMTT**

Loading and off-loading operations require a wood block ramp brace 20 by 11 by 10.5 inches and stair-stepped plywood approach shoring, seven pieces on each side. Air Force publications state and expand on these requirements. Wood should be pre-cut and on hand for each vehicle.

The HEMTT must be backed into the aircraft. Minimal clearance requires skilled and experienced drivers in the HEMTTs.

All LPCs or GMLAs and the HEMTT spare tire must be removed for up-loading.

## FM 6-60

### M270 Launcher

The M270 hatch cover and antennas must be removed, and the driver's louver must be down over the windshield.

The launcher is driven forward onto the aircraft with C141B winch assistance.

Plywood matting is required on the tarmac (approach to aircraft) and within the aircraft.

**Note:** A DD Form 2133 (Joint Airlift Inspection Record) must be completed for each aircraft. (See Figure A-1, page A-3.)

Each type of transport aircraft has a specific manifest form which must be completed for transporting MLRS cargo. (See the sample MAC Form 749 [C-5A Passenger/Cargo Manifest] Figure A-2, page A-4.)

JOINT AIRLIFT INSPECTION RECORD											
1. UNIT BEING AIRLIFTED				2. DEPARTURE AIRFIELD			3. DATE				
4. TYPE ACFT AND SERIAL NO.		5. MISSION NO.		6. LOAD/CHALK NO.		7. TIME COMPLETED		8. ALCE			
<b>LEGEND (Mark blank after each item as follows)</b> <input checked="" type="checkbox"/> = Satisfactory      X = Unsatisfactory N/A = Not Applicable				INCREMENT/SERIAL/BUMPER NUMBER AND TYPE							
<b>A. PREPARATION</b>											
9. Clean (No dirt, trash, pests)											
10. No fluid leaks											
11. Scale weight (Both sides)											
12. Center of balance (Both sides)											
13. Fuel tanks 1/4 to 3/4 (1/2 aircraft ramp)											
14. Fuel tank caps (As required)											
15. Jerry cans secured (Maximum 5 gallons)											
16. Size reduction—antennas, bows											
17. Dimensions (Fits aircraft envelope)											
18. Battery secured											
19. Vehicle equipment secured											
(a) Axe, shovel, pick											
(b) Spare wheel, tools, bow											
20. Mechanical condition											
(a) Engine runs											
(b) Brakes											
21. Tire pressure (Maximum 100 PSI)											
22. Tie down points											
23. Pins for pinning hooks and sleeves											
24. Tankers (Drained and purged)											
25. DD Form 1382-2 (As required)											
26. Manifests/number of copies											
<b>B. ACCOMPANYING LOAD</b>											
27. Secured to vehicle 1 Os, 3 Os											
28. Within rated capacity											
29. Compatible cargo (IAW AFR 71-d)											
30. DD Form 1387-2 (As required)											
<b>C. SPECIAL REQUIREMENTS</b>											
31. Shoring - rolling, parking											
32. Ramp											
<b>D. PALLETS</b>											
33. Dimensions - width, height											
34. DD Form 1387-2 (As required)											
35. Compatible with other cargo											
36. Cargo properly secured											
(a) Nailed											
(b) Chained											
37. Inventory list of dangerous materials on the pallet - signed by the shipper											
<b>E. HELICOPTERS (Flyaway)</b>											
38. Battery disconnected											
39. Fuel quantity - 1/4 to 3/4 full											
40. Scale weight (Both sides)											
41. Center of balance (Both sides)											
<b>F. CORRECTED ITEMS</b>				43. REMARKS							
42. BLOCK NO.	LEGEND	42. (Cont)								LEGEND	
A.		F.									
B.		G.									
C.		H.									
D.		I.									
E.		J.									
44. TRANSPORTED FORCE INSPECTOR SIGNATURE					45. AIR FORCE INSPECTOR SIGNATURE						

DD FORM 2133  
1 SEP 77

Figure A-1. Joint Airlift Inspection Record.



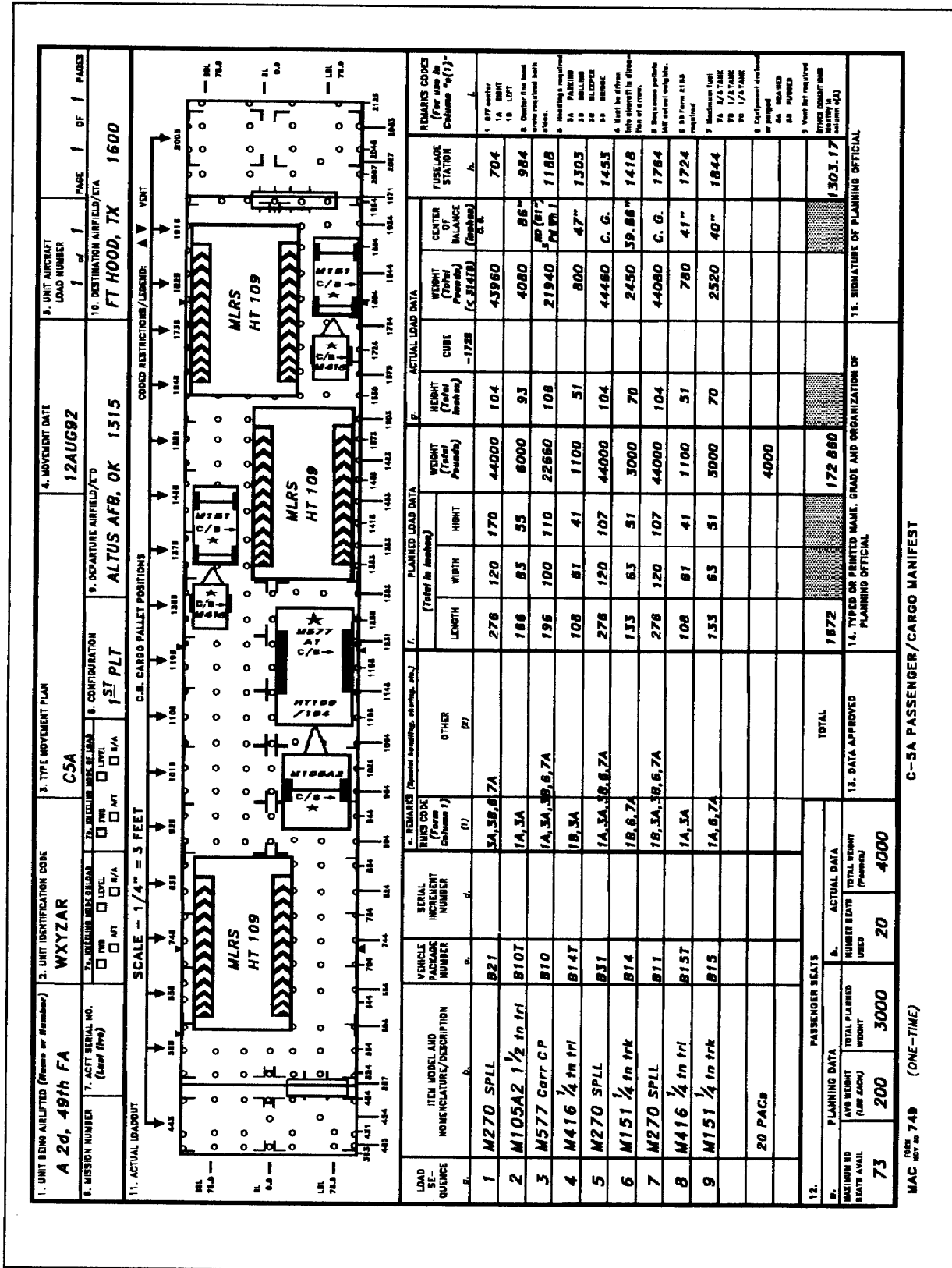

Figure A-2. C-5A Passenger/Cargo Manifest.

## APPENDIX B

## FIELD ARTILLERY SUPPORT PLAN

The written FA support plan is an appendix to the fire support annex to a maneuver force OPORD. The FA support plan provides for coordinated action to carry out the decisions of the FA unit commander in support of the maneuver operation.

## Field Artillery Support Plan Format

The FA support plan follows the format of the five-paragraph OPORD and refers to both the maneuver force OPORD and its fire support annex. However, not all of the commanders and staffs of the units supporting the force FA headquarters preparing the FA support plan will receive copies of the maneuver force OPORD or its fire support annex. Therefore, the FA support plan may reiterate critical items of information to ensure that all

commanders and staffs receive the information. The FA support plan should not include information already available in unit SOPs. The purpose of the written plan is to inform subordinate and supporting units of tasks and requirements that are peculiar to a specific operation.

The format for a FA support plan begins on the next page. Explanations are given for the various paragraphs and subparagraphs in the relevant portions of the order.

## ACRONYMS AND ABBREVIATIONS USED IN THE EXAMPLE FIELD ARTILLERY SUPPORT PLAN

<b>ACP</b>	= air control point	<b>FSCM</b>	= fire support coordinating measure	<b>PA</b>	= position area
<b>ADA</b>	= air defense artillery	<b>HA</b>	= hide area	<b>PL</b>	= phase line
<b>AIRCOR</b>	= air corridor	<b>HEMTT</b>	= heavy expanded-mobility tactical truck	<b>REC</b>	= radio-electronic combat
<b>alt</b>	= altitude	<b>HPT</b>	= high pay-off target	<b>rkt</b>	= rocket
<b>app</b>	= appendix	<b>HVT</b>	= high-value target	<b>RSTA</b>	= reconnaissance, surveillance, and target acquisition
<b>atch</b>	= attached	<b>ICE</b>	= individual chemical equipment	<b>SIMO</b>	= simultaneous observation
<b>avn</b>	= aviation	<b>ID (M)</b>	= infantry division (mechanized)	<b>SITREP</b>	= situation report
<b>az</b>	= azimuth	<b>LOC</b>	= lines of communication	<b>spt</b>	= support
<b>C3</b>	= command, control, and communications	<b>man</b>	= maneuver (attack guidance matrix)	<b>survl</b>	= surveillance
<b>cat</b>	= category	<b>max</b>	= maximum	<b>TACMS</b>	= tactical missile system
<b>coord</b>	= coordinate	<b>mod</b>	= modification	<b>TBP</b>	= to be published
<b>COP</b>	= command observation post	<b>MRL</b>	= multiple rocket launcher	<b>TD</b>	= tank division (Threat)
<b>CRP</b>	= combat reconnaissance patrol	<b>msl</b>	= missile	<b>TDA</b>	= target damage assessment
<b>CSB</b>	= common sensor boundary	<b>msn</b>	= mission	<b>TLE</b>	= target location error
<b>DNE</b>	= do not engage	<b>NLT</b>	= not later than	<b>TVA</b>	= target value analysis
<b>EA</b>	= engagement area			<b>w</b>	= with

## FM 6-60

# FIELD ARTILLERY SUPPORT PLAN FORMAT

(CLASSIFICATION)

The classification is placed at the top and bottom of each page of the document.

### Copy of copies

Unit preparing the order

Geographic location

Date-time group (DTG) of order

## APPENDIX \_\_ (FA SUPPORT PLAN) TO ANNEX \_\_ (FIRE SUPPORT) TO OPORD \_\_ Supported Maneuver Force

**Reference:** Maps to be used during the operation.

**Time Zone Used Throughout Order:** TIME ZONE.

### 1. SITUATION.

Paragraph 1 includes items of information affecting FA operations that may or may not be included in paragraph 1 or in the Fires paragraph of the OPORD or in the fire support annex. It gives an overview of the general situation so subordinate commanders can understand the environment in which they will be operating. This paragraph is used exclusively to provide information. If all organic, attached, or supporting commanders do not receive complete copies of the maneuver OPORD and the fire support plan, then the FA support plan must repeat those items critical to the execution of their missions.

**a. Enemy Forces.** This subparagraph provides enemy information vital to the FA unit. This includes enemy indirect fire capabilities which may influence fire support activities, the ground threat, the air threat, and any other enemy information of particular relevance to the FA units. Reference may be made to an intelligence annex, an overlay, a periodic intelligence report, or an intelligence summary (INTSUM).

**b. Friendly Forces.** This subparagraph shows the missions of higher headquarters and/or of supported maneuver elements. Missions of adjacent supporting, and reinforcing units may also be outlined here. Information should be limited to that which subordinate commanders need to know to accomplish their missions. The supported maneuver force commander's intent for fire support is also included in this subparagraph as well as the force FA commander's intent during GS and GSR missions.

**c. Attachments and Detachments.** This subparagraph should list units attached to and detached from the FA unit, including the terms of attachment and effective DTGs if appropriate. This includes attached target acquisition assets and sensor system down-links as well as detached batteries.

### 2. MISSION.

Paragraph 2 is a clear, concise statement of the task the FA unit is to accomplish. As a minimum, it should answer the questions *who*, *what*, *when*, *where*, and *why*. It includes essential tasks determined by the commander as a result of his mission analysis.

(CLASSIFICATION)

## FIELD ARTILLERY SUPPORT PLAN FORMAT (Continued)

(CLASSIFICATION)**3. EXECUTION.**

Paragraph 3 contains the “how-to” information needed for mission accomplishment.

**a. Concept of Operation.** This subparagraph is a statement of the commander’s visualization of the conduct of the operation in order to reach the desired end state. The concept clarifies the purpose of the operation and is stated in enough detail to ensure appropriate action by subordinates in the absence of additional specific instructions. The FSCoord or FA battalion commander’s intent is included in this subparagraph.

**b. Organization for Combat.** This subparagraph gives a clear statement of the organization and tactical missions of the subordinate elements of the FA headquarters. Anticipated on-order changes to organization or tactical missions are included in this subparagraph.

**c.\*\*\***

**d.\*\*\***

**e.\*\*\***

Subsequent subparagraphs in paragraph 3 build on the concept of the operation. They should provide the artillery organization for combat, priority of fires, priority of Army TACMS and other MFOM, positioning and movement instructions, and specific tasks to be accomplished by specific subelements.

**f. Coordinating Instructions.** The last subparagraph in paragraph 3 includes instructions and details of coordination applicable to two or more subelements of the FA unit. This paragraph should include instructions concerning the following:

- Target acquisition (includes a counterfire reference grid and instructions to or about specific target acquisition sources).
- Survey (includes priorities for survey, accuracies required [if other than SOP], sources authorized [PADS, PLGR, SRP/PDS], timing, position requirements, and future plans).
- High-payoff target list (from force FSE).
- Attack guidance matrix (from force FSE).
- NBC defense (includes MOPP, operation exposure guidance, and decon instructions).
- Meteorology (includes source, type, and times of met messages).
- Fire plan (includes a target list and schedules of fires).
- Fire support coordinating measures (FSCMs).
- PIR and/or IR.
- Intelligence acquisition tasks (as appropriate).
- Ammo restrictions (includes expenditure restrictions, approval requirements, and risk limitations for DPICM based on expected dud rates).

Many issues included in coordinating instructions may also be addressed in tabs to the FA support plan. If a separate tab is used, include only items of general interest in the coordinating instructions paragraph. Details of interest only to a particular element are placed in the tab. If a tab is prepared, reference it (See Tab \_\_.) in the body of the support plan.

(CLASSIFICATION)

FIELD ARTILLERY SUPPORT PLAN FORMAT (Continued)

(CLASSIFICATION)

4. SERVICE SUPPORT.

Paragraph 4 includes specific service support instructions and arrangements supporting the operation. The commander's direction regarding CSS will be here. Supply, maintenance, medical, and personnel information are included in this paragraph. As a minimum, the CSR and the CSS locations (unit [ALOC], casualty collection points, LRP, ATPs, ASP, and UMCP) should be given.

5. COMMAND AND SIGNAL.

Paragraph 5 includes two subparagraphs.

**a. Command.** The first subparagraph should list the locations of the unit TOC and higher, supporting, and supported unit TOCs. The commander's planned location during the operation can be in this paragraph. Designation of an alternate TOC is written here.

**b. Signal.** The second subparagraph contains the index of the effective SOI. Instructions on the use of radio and instructions for wire and retrans elements are written here. Additionally, SINCGARS Frequency hop instructions (if deviating from unit SOP), specific data communications requirements, and MSE instructions peculiar to the operation should be included.

**Acknowledge:**

ISSUING COMMANDER'S NAME  
RANK

OFFICIAL:

/Signed/

S3/s NAME

S3

TABS: A-

B-

C-

D-

E-

Tabs should be prepared for portions of the plan that are better explained in a different format (for example, as an overlay or a matrix), that are too extensive to be in the plan, that are expected to change or lengthen, or that are submitted too late to be included in the FA support plan. Common tabs include the following:

- FA support matrix.
- Target lists.
- Fire plan (schedules).
- Survey tab.
- Target acquisition tab.
- TACFIRE /IFSAS tab (FDS/FDDM links, subscriber tables).
- FA positioning and/or movement overlay.

(CLASSIFICATION)

## APPENDIX C

## ROCKET BALLISTICS

### Requirements for Accurate Predicted Fire

There are fire general requirements for achieving accurately predicted fire. These requirements are accurate target location and size, firing unit location, weapon and ammunition information, met information, and computational procedures. If these requirements are satisfied, the firing unit will be able to deliver accurate and timely fires.

#### Target Location and Size

Accurate and timely detection, identification, and location of ground targets and the determination of their size and disposition on the ground are essential for accurately computing firing data. Determining the appropriate time and type of attack requires that the target size (radius or other dimensions) and the direction and speed of movement be considered. Target location is primarily determined by use of target acquisition assets and sensing platforms. Other sources include maneuver FSEs and special operations forces.

#### Launcher Location

The PADS provides accurate survey data for survey control points used by launchers. Accurate firing point location is a function of the launcher SRP/PDS based on the initial survey data. It can also be derived at the firing point directly from GPS.

#### Weapon and Ammunition Information

The ballistic algorithm imbedded in the EU of the launcher FCS takes into account specific ammunition information (weight ambient temp, and ammunition type).

#### Solution Meteorological Information

The effects of weather on the rocket must be considered and the firing solution must compensate for those effects. Use of current meteorological information in the FCS allows the firing solution to compensate for current weather conditions (see Chapter 4 for time and space validity considerations and responsibilities regarding met verification).

### Computational Procedures

The computation of firing data must be accurate. Special applications programs (SPAR) programmed in the launcher FCS yield accurate and timely firing data. Individual and collective training reduce the probability of procedural or data input error.

### Rocket Error Sources

#### Bias Errors

Bias Errors affect all rockets of a mission. They are "occasion to occasion" errors. Example - errors in measurement of wind speed or direction, errors in measurement of air density.

**Boost Wind.** This is the unpredictable error between the measured wind velocity and the wind velocity that the rocket actually encountered during the initial launch stage. The MFOM rockets are extremely sensitive to the low level winds due to the relatively low velocity of the rocket as it leaves the launch tube. The resulting effect produces a path heading error in the first few seconds of flight.

**Coast Wind.** This is the unpredictable error between the measured wind velocity and the wind velocity that the rocket actually encountered during the majority of its flight (upper level winds).

Standard tactical meteorological system reports a measurement that is two hours old and is taken a number of kilometers away from the rocket flight path. This spatial and temporal difference is the major contributor to the random bias error associated with both boost and coast winds.

**Impulse.** This is the difference between the average total impulse of the rocket motors in the pod and that of the nominal motor. This error is controlled by manufacturing tolerances and system design.

**Drag.** This is the difference between the average aerodynamic drag of the rockets in the pod compared to the perfect nominal rocket. This error is also controlled by manufacturing tolerances and system design.

**Ambient Temperature.** This is the unpredictable difference between the measured temperature of the atmosphere and the actual temperature experienced by the rocket. Temperature is a variable used to compute air densities which in turn is used to compute drag.

**Pressure.** This is the unpredictable difference between the measured pressure of the atmosphere and the actual pressure experienced by the rocket. Pressure is also a variable used to compute air density and ultimately drag.

**Position Determining System (PDS).** There are errors created by the onboard position determining system. The majority of range errors are due to the inaccurate determination of launcher altitude. This error is independent of rocket design or manufacture.

**Submunition.** These errors are primarily due to unaccounted and unknown winds in the target area.

**Rocket/Stabilization Reference Package (SRP) Misalignment.** This error is due to a misalignment of the launch pod and/or rockets and the SRP. This error is controlled by system design, manufacturing tolerances, and launcher maintenance procedures.

**Precision Errors**

Precision errors are caused by variations between rockets. Example - variations in launch weight, variations in rocket motor total impulse (see Figure C-1).

**Mal-Launch.** Mal-launch is the apparently random "kick" given to the rocket while it is exiting the launch tube. It is created through a complex and not well understood interaction of the rocket with the launch pod, the sabots, launcher, and exhaust gases. Mal-launch rates are usually derived indirectly and quoted as an angular rate at tube exit and are not predictable.

**Drag.** Drag variability is the random rocket-to-rocket variability of the drag characteristics.

**Impulse.** Impulse variability is the random rocket-to-rocket variability of the rocket motor.

**Submunition.** This factor is caused primarily by the height of burst (HOB) precision variability. Varying HOBs will allow a variable amount of wind drift to affect the submunition secondary trajectory.

**Mass Unbalance.** Mass unbalance is the unbalanced condition of the rocket as it leaves the launch tube. An unbalanced condition will create a real-launch condition.

**Thrust Malalignment.** This is the condition where the motor thrust is not aligned with the rocket center. The effect of this has been minimized by the use of rocket rotation.

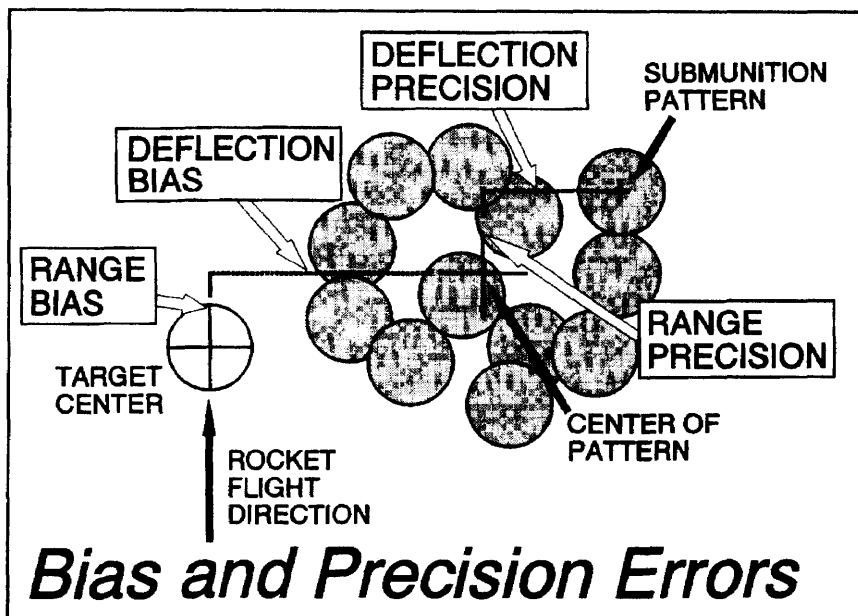

Figure C-1. Bias and precision errors.

APPENDIX D

**MLRS BATTALION AND BATTERY  
TACTICAL STANDING OPERATING PROCEDURES**

This appendix is designed as a guide and checklist for preparing a field artillery TSOP for the MLRS battalion and MLRS battery. This appendix is not intended to be all-inclusive regarding the information required by an individual unit TSOP. These TSOP outlines are recommended for use by all MLRS battalions and MLRS batteries to standardize TSOPs within the MLRS community. MLRS platoon operations are usually covered within the MLRS battalion or battery TSOP; therefore, a separate MLRS platoon TSOP will not be addressed.

**General**

The TSOP is a set of instructions covering those features of operations which lend themselves to a definite or standardized procedure to increase effectiveness. The TSOP is an order from the commander that tells his staff and subordinates how he intends to run his unit. Procedures outlined in the unit TSOP apply unless the commander orders otherwise.

This appendix provides an outline for use in developing a TSOP. A sample format is provided for use by all MLRS battalions and MLRS batteries. Standardized formats are very helpful to newly assigned personnel who must quickly find the answers to operations questions. When TSOPs are exchanged with other units during coordination or liaison, they help both units understand the operating procedures of the other.

**TSOP Format**

The basic format of a TSOP is the implementing memorandum with attached annexes and appendices. Additionally, a table of contents for attached annexes may be inserted to provide a quick reference to information contained in the TSOP.

Normally, TSOPs are unclassified to facilitate distribution to all levels that need to have the information. However, selected portions of the TSOP may be classified and should be identified as such in the table of contents.

**Note:** Normally, each annex would start on a separate page. However, for presentation here, page breaks are shown by a line between each annex.

**LEGEND**

AD	= air defense	MWR	= morale, welfare, and recreation
BDAR	= battlefield damage assessment and repair	ORF	= operationally ready floats
CI	= civilian internee	PERSTAT	= personnel status
EI	= essential elements of information	ROM	= refuel on the move
LOGPAC	= logistics package	SALUTE	= size, activity, location, unit, time and equipment (memory aid)
LOGSTAT	= logistics status	SITREP	= situation report
MEDEVAC	= medical evacuation	TACJAM	= tactical jamming
MI	= military intelligence	WSRO	= weapon system replacement
MIJI	= meaconing, intrusion, jamming, and interference operations		
MOPP	= mission oriented protective posture		



---

**Section I**  
**IMPLEMENTING MEMORANDUM (Battalion and Battery)**

---

DEPARTMENT OF THE ARMY  
Unit  
Location

OFFICE SYMBOL

Date

MEMORANDUM FOR SEE DISTRIBUTION

SUBJECT: Tactical Standing Operating Procedures

1. REFERENCES. This paragraph should contain all references that support the TSOP. A primary reference is the TSOP of the unit's higher headquarters with which it must operate. In cases where a unit has contingency missions with more than one higher headquarters, its TSOP should be written for the primary mission and annotations should be made within the text as appropriate where procedures differ.

2. APPLICABILITY/SCOPE. The purpose of this paragraph is to outline the applicability and/or scope of the TSOP. The paragraph below is one example.

This TSOP covers only wartime operations after deployment. This TSOP does not and will not repeat doctrine, tactics, or techniques that are provided in FMs, TMs, and MTPs. It applies to all organic, assigned, attached, and OPCON units. It also applies to all supporting units operating in or occupying areas within the battalion or battery area of operation. All TSOP provisions apply except as modified by operations orders and plans. No provision will replace good judgment and common sense.

3. PURPOSE. The purpose of this paragraph is to describe the purpose of the TSOP. The paragraph below is one example.

This TSOP prescribes guidance for the conduct of sustained tactical operations. Specifically, it standardizes those routine and/or recurring operational procedures and responsibilities of individuals and/or organic and supporting elements.

4. GUIDANCE TO SUBORDINATE UNITS. As appropriate.

5. PROPONENCY. Overall proponency is usually the battalion S3 or the operations officer at the battery level. The proponent for each annex and appendix may be listed in this paragraph if applicable.

6. CHANGES. The purpose of this paragraph is to outline procedures for making changes to the TSOP. Consider the following topics for inclusion in this paragraph:

- Who is responsible for writing and coordinating changes. Normally the proponent of each annex and/or appendix is responsible for writing changes to his respective annex and/pr appendix.
- Who approves changes. Normally the commander approves changes to the TSOP, but the procedure for approval and dissemination must be specified.
- How changes are to be posted. The TSOP should be preceded by a posted changes page.

SIGNATURE BLOCK  
RANK, FA  
Commanding

DISTRIBUTION: Distribution is usually made in accordance with a unit distribution scheme, such as "DISTRIBUTION A." Whether distribution is made in accordance with a unit distribution scheme or listed by element and number of copies, the following should be considered:

- What elements need copies within the battalion or battery?
- How many copies are needed by each element?
- Distribution of changes.
- Liaison officer team distribution during operations.
- Distribution to external elements.

---

## Section II BATTALION TSOP

---

### TABLE OF CONTENTS

#### ANNEX A. OPERATIONS

Appendix	1-Battalion Command Post
	2-Liaison
	3-Movement and Positioning
	4-Command and Control
	5-Fire Direction
	6-Survey and Meteorological Support
	7-HHSB Operations
	8-Firing Battery Operations
	9-Firing Platoon Operations
	10-Launcher Operations
	11-Civil Military Operations
	12-Emergency Destruction

#### ANNEX B. INTELLIGENCE

#### ANNEX C. AIR DEFENSE

#### ANNEX D. NBC

Appendix	1-NBC Operations
	2-NBC Decontamination
	3-MOPP
	4-NBC Threat Warning and Alarm System

#### ANNEX E. SIGNAL

Appendix	1-Radio Communications
	2-MSE Communications
	3-Communications Security
	4-Resynchronization

#### ANNEX F. COMBAT SERVICE SUPPORT

Appendix	1-Battalion Trains
	2-Administrative/Logistics Operation Center
	3-Personnel Administration
	4-Supply Operations
	5-Ammunition Management and Resupply Operations
	6-Services
	7-Unit Ministry Operations
	8-Maintenance Operations
	9-Refueling Operations
	10-Reconstitution
	11-Medical Support Operations

#### ANNEX G. SAFETY

#### ANNEX H. REPORTS

Appendix	1-Personnel and Administration Reports
	2-Intelligence and Security Reports
	3-Operations Reports
	4-Logistical Reports
	5-NBC Reports
	6-Communications and Electronics Operations Reports

**Note:** Tabs may be used to further divide an appendix if an appendix has many subparts and is considered too lengthy. An example page for a tab is as follows A-1-A-1. This means page 1 of tab A to Appendix 1 of Annex A. Subsequent pages within the tab are numbered sequentially as A-1-A-2, A-1-A-3, and so forth. Tabs may be included in the table of contents.

## **ANNEX A (Operations) to \_\_\_\_\_ Bn, \_\_\_\_\_ FA (MLRS)TSOP**

The purpose of this annex is to prescribe operations within the battalion. Consider the appendixes below for inclusion in this annex.

**Appendix 1- Battalion Command Post.** This appendix shows the physical setup of the battalion CP and establishes internal CP operating procedures. Consider the following topics for inclusion in this appendix:

- CP manning.
- Shift organization and sleep plan.
- Shift changeover time and procedures.
- Overall CP lay down with vehicles.
- TOC internal setup.
- CP communications (internal and external).
- Specific duties and responsibilities.
- Priorities of work.
- Access control.
- Security.
- Load plans.

**Appendix 2- Liaison.** This appendix outlines the duties and responsibilities for liaison personnel. Consider the following topics:

- Organization
- Transportation.
- Communications.
- Checklist for liaison team.
- Liaison functions.
- Liaison responsibilities to supported unit.
- Liaison responsibilities to parent unit.
- Prioritization and formation of ad hoc teams, as required.
- Load plans.

**Appendix 3- Movement and Positioning.** This appendix prescribes movement and positioning requirements, procedures, and techniques used within the battalion. Consider the following topics:

- Specific duties and responsibilities.
- Movement orders.
- Movement techniques and METT-T.
- Positioning in the offense.
- Positioning in the defense.

- Displacement options.
- Convoy procedures.
- Command and control during movement.

**Appendix 4- Command and Control.** This appendix outlines how the battalion will be commanded and controlled. Consider the following topics:

- Responsibilities for command and control.
- Orders process.
- Orders distribution.
- Orders format.
- Succession of command.
- Transfer of CP operations.
- Alternate CP.
- Jump CP operations.
- Assignment of rocket or missile missions to batteries.

**Appendix 5- Fire Direction.** This appendix standardizes tactical fire direction procedures and information. Consider the following topics:

- Personnel responsibilities.
- Initialization.
- Equipment maintenance.
- Communications procedures.
- Degraded mode operations procedures.
- Battalion fire direction procedures.
- Platoon and battery fire direction procedures.
- Massed fire procedures.
- Subscriber tables.

**Appendix 6- Survey and Meteorological Support.** This appendix prescribes survey operations and identifies responsibilities and procedures for receiving and disseminating met messages. Consider the following topics:

- Personnel responsibilities.
- Survey priorities (for example, PADS, simultaneous observation, and hasty survey).
- Radio communications and requests for survey.
- SCP locations and markings.
- GPS procedures.
- Datum coordination and control.
- Extension of survey.
- Alternate met procedures in case of electronic failure.
- Met message dissemination times.
- Coordination of met requirements.

## FM 6-60

**Appendix 7- HHSB Operations.** This appendix prescribes operating procedures for the HHSB. Consider the following topics:

- Tactical organization.
- Personnel and section responsibilities.
- RSOP.
- Advance party configuration, equipment, and procedures.
- HHSB rearm, refuel, and refit operations.
- Load plans.

**Appendix 8- Firing Battery Operations.** This appendix prescribes operating procedures for firing batteries. Consider the following topics:

- Battery deployment configurations.
- Battery OPAREA.
- Battery CP lay down with vehicles.
- BOC and LOC internal setups.
- BOC and LOC manning.
- BOC and LOC shift organizations and sleep plan.
- Shift changeover time and briefing procedures.
- Communications (internal and external).
- Specific duties and responsibilities.
- RSOP.
- Advance party configuration, equipment, and procedures.
- Security.
- Load plans.
- Rearm, refuel, and refit operations.

**Appendix 9- Firing Platoon Operations.** This appendix prescribes operating procedures for firing platoons. Consider the following topics:

- Platoon deployment configurations.
- Platoon OPAREA.
- POC internal setup.
- Sleep plan.
- Communications (internal and external).
- Fire direction (hot, cool, cold status; ammo status).
- Positioning (firing points, ammo supply points, survey control points, and rendezvous point).
- Specific duties and responsibilities.
- RSOP.
- Advance party configuration, equipment, and procedures.

- Security.
- Load plans.

**Appendix 10- Launcher Operations.** This appendix prescribes operating procedures for launchers. Consider the following topics:

- Fire direction (status, response time, and start-up data).
- Positioning (site selection, making, and survey).
- Movement.
- Security.
- Specific duties and responsibilities.

**Appendix 11 - Civil Military Operations.** This appendix prescribes operating procedures for civil military operations. Consider the following topics:

- Specific duties and responsibilities.
- Communications and coordination with local and/or host nation officials.
- Refugee control.
- Local and/or host nation support.

**Appendix 12- Emergency Destruction.** This appendix prescribes procedures within the battalion. Consider the following topics:

- Specific duties and responsibilities.
- Priorities.
- Methods.
- Verification and reporting.

---

### **ANNEX B (Intelligence) to \_\_\_\_\_Bn, \_\_\_\_\_FA (MLRS) TSOP**

This annex prescribes intelligence operations within the battalion. Consider the following topics:

- Specific duties and responsibilities.
- Control and destruction of classified documents.
- EPW procedures.
- Returnees.
- Security.
- Weather.
- Mapping, charting, and geodesy.
- TACJAM procedures.
- EEI.
- IPB.
- Interface with MI and USAF sensing platforms.

---

**ANNEX C (Air Defense) to \_\_\_\_\_ Bn, \_\_\_\_\_ FA (MLRS) TSOP**

This annex prescribes air defense operations within the battalion. Consider the following topics:

- AD procedures (active and passive).
- AD warning and weapons control status.
- Hostile aircraft criteria.
- Rules of engagement.
- Attached AD elements (C2 of and support for).

---

**ANNEX D (NBC) to \_\_Bn\_\_ FA (MLRS) TSOP**

This annex provides NBC defense information and prescribes NBC operations within the battalion.

**Appendix 1 - NBC Operations.** This appendix prescribes NBC readiness and defense operations. Consider the following topics:

- Individual skills.
- NBC teams and/or control parties.
- Warning devices.
- Collective skills.
- Radiation exposure guidance.
- Unmasking procedures.
- Threat assessment.
- Hazard overlay.

**Appendix 2- NBC Decontamination.** This appendix establishes NBC procedures. Consider the following topics:

- Specific duties and responsibilities.
- Decontamination procedures and levels of decontamination.
- Requests for decontamination support from batteries and platoons and from higher headquarters.

**Appendix 3- MOPP.** This appendix provides easily accessible information and standardizes wear of protective clothing and use of equipment. Consider the following topics:

- MOPP levels and dissemination of MOPP.
- Standardized wear of MOPP gear (for example, name labels, and so forth).
- Requisition and issue of protective clothing and equipment.
- Location and contents of individual protective clothing and equipment bags.

**Appendix 4- NBC Threat Warning and Alarm System.** This appendix provides easily accessible information and establishes NBC threat warning and alarm procedures and priority means of dissemination within the battalion.

---

## ANNEX E (Signal) to \_\_Bn\_\_ FA (MLRS) TSOP

This annex prescribes signal operations within the battalion. Consider the following topics:

- Specific duties and responsibilities (staff, batteries, and platoons).
- Comm integration with higher, lower, supported, and adjacent units.
- Signal equipment maintenance.

**Appendix 1- Radio Communications.** This appendix provides radio comm information and prescribes radio comm procedures. Consider the following topics:

- External net diagrams.
- Internal net diagrams.
- Priority of nets.
- Specific operating and setup procedures (for example, net control, use of antennas, and so forth).

**Appendix 2- MSE Communications.** This appendix provides MSE comm information and prescribes MSE comm procedures. Consider the following topics:

- Affiliation codes and procedures.
- Disaffiliation procedures.
- RAU positioning and coverage.
- J-1077 positioning and access.
- Subscriber information.

**Appendix 3- Communications Security.** This appendix establishes comm security procedures. Consider the following topics:

- COMSEC changeover times and procedures.
- Distribution of COMSEC material.
- Loss and recovery of COMSEC material.
- SOI procedures.
- VINSON and MSRT variable control.
- Remote keying procedures.
- MSRT compromise and recovery procedures.
- GPS COMSEC

**Appendix 4- Resynchronization.** This appendix prescribes procedures to desynchronize serialization of digital systems to correct serialization without voice transmission.

---

## ANNEX F (CSS) to \_\_Bn\_\_ (MLRS) TSOP

This annex prescribes CSS operations within the battalion.

**Appendix 1- Battalion Trains.** This appendix shows the physical setup of the battalion trains and establishes internal operating procedures. Consider the following topics:

- Specific duties and responsibilities.
- Trains area layout (vehicles and sections).



## FM 6-60

- Internal communications.
- Security.
- Movement and positioning.

**Appendix 2 -ALOC.** This appendix shows the physical setup of the ALOC and establishes internal ALOC operating procedures. Consider the Following topics:

- Specific ALOC functions.
- ALOC manning.
- Shift organization and sleep plan.
- Shift changeover time and briefing procedures.
- ALOC internal setup.
- C3.
- Specific duties and responsibilities.
- Priorities of work.
- Load plans.

**Appendix 3- Personnel Operations.** This appendix prescribes personnel operations within the battalion to support the soldier and batteries. Consider the following topics:

- Maintenance of unit strength (all levels within the battalion).
- Personnel replacement operations.
- Personnel accounting and strength reporting.
- Personnel data base management.
- Casualty management.
- Postal operations.
- EPW and CI operations.
- MWR.
- Other personnel functions (orders, evaluation reports, promotions, personnel actions, personnel assignment and utilization, and awards).
- LOGPAC input.

**Appendix 4- Supply Operations.** This appendix prescribes procedures to request, receive, store, and issue supplies. Consider the following topics:

- Specific duties and responsibilities.
- Management of supplies.
- Requisition, flow, and supply distribution (prioritize when applicable).
- All classes of supply (controlled and noncontrolled).
- Water operations, requirements, and points.
- Map supply.
- Publications and blank forms.

- Tabs for preplanned LOGPACs.
- Specific categories of supply (for example, NBC, communications, and small arms).

**Appendix 5- Ammunitions Management and Resupply Operations.** This appendix prescribes ammunition management and resupply procedures. Consider the following topics:

- Specific duties and responsibilities.
- Requests.
- Resupply procedures used within the battalion.

**Appendix 6- Services.** This appendix describes logistics support services within the battalion. Consider the following topics:

- Laundry.
- Clothing exchange.
- Showers.
- CTA-50 exchange.
- Graves registration.

**Appendix 7- Unit Ministry Operations.** This appendix prescribes unit ministry operating procedures. Consider the following topics:

- Communications.
- Priority of coverage.
- Coordination of religious services.
- Chaplain support activities.
- Mass burial.
- Civil actions.
- Supplies and logistic support.
- Accommodation of religious practices.
- Lay minister functions.

**Appendix 8- Maintenance Operations.** This appendix prescribes maintenance operations. Consider the following topics:

- Specific duties and responsibilities.
- Maintenance priorities.
- Recovery and evacuation priorities.
- Cannibalization and controlled substitution.
- BDAR.
- WSRO.
- Contact teams.
- Equipment density listing.
- Repairable and returnable components and assemblies.
- ORF.

## FM 6-60

- Equipment evacuation.
- COMSEC maintenance.

**Appendix 9- Refueling Operations.** This appendix prescribes refueling operations within the battalion. Consider the following topics:

- Specific duties and responsibilities.
- Fuel request procedures and priorities.
- ROM.
- Day procedures and template.
- Night procedures and template.
- Security.
- Safety.

**Appendix 10- Reconstitution.** This appendix prescribes procedures to reconstitute the battalion when it falls below an unacceptable level of combat readiness. Consider the following topics:

- Specific duties and responsibilities.
- Requirement to reconstitute (mass casualties, mass destruction of equipment, and the destruction or loss of effectiveness).
- Method of reconstitution (reorganization and regeneration).

**Appendix 11- Medical Support Operations.** This appendix prescribes medical support operations, Consider the following topics:

- Specific duties and responsibilities.
- Locations and deployment configurations of medical assets-CP and/or trains.
- Assignment of medics.
- Communications.
- Field sanitation.
- Combat lifesaver training.
- Evacuation and reporting procedures.
- Priority of evacuation.
- Collection and accountability of individual equipment and effects.
- Treatment and prevention of disease.
- Mental health, dental, and other essential services.

---

## ANNEX G (Safety) to \_\_\_ Bn, \_\_\_ FA (MLRS) TSOP

This annex prescribes combat safety requirements and provides risk assessment procedures within the battalion.

**Appendix 1- Safety Information and Reporting.** This appendix prescribes how command safety information will be distributed and the requirements and means for rendering accident and incident reports.

**Appendix 2- Firing Safety.** This appendix prescribes combat firing safety requirements.

---

## ANNEX H (Reports) to \_\_Bn,\_\_FA(MLRS TSOP)

This annex provides a single consolidated section within the TSOP to prescribe report requirements within the battalion. Normally, reports are segregated by staff functional area. Reports should be tailored to specific requirements of higher headquarters and the commander's need for input into his decision-making process. Avoid requiring information that is duplicated in other reports or that is of minimal value. To the greatest extent possible, coordinate report transmission and effective times to reduce workloads and to synchronize staff actions. The means for submitting each report and the priority of each means must be addressed. Many reports are submitted as required and should be so indicated. Consider the reports below within this annex.

**Appendix 1- Personnel and Administration Reports.** Consider the following:

- PERSTAT report.
- Casualty feeder report.
- MEDEVAC request.

**Appendix 2- Intelligence and Security Reports.** Consider the following:

- Weather report.
- SALUTE report.
- Sensitive items report.

**Appendix 3- Operations Reports.** Consider the following:

- SITREP.
- Launcher status report.
- Voice or manual fire mission.
- Recon order.
- Movement order.
- Closing report.
- Request to displace.
- Ammunition assets report.

**Appendix 4- Logistical Reports.** Consider the following:

- LOGSTAT report.
- Equipment status report.
- Combat loss report.
- Logistical spot report.
- Emergency resupply request (ammunition and fuel).

**Appendix 5- NBC Reports.** Consider the following:

- NBC 1 report.
- NBC 2 report.
- NBC 3 report.

- NBC 4 report.
- NBC 5 report.
- NBC 6 report.
- Chemical downwind message.
- Effective downwind message.
- Request for decontamination support.
- Radiation status report.

**Appendix 6- Communications and Electronics Operations Reports.** Consider the MIJI feeder report.

---

Section III  
**MLRS BATTERY TSOP**

---

TABLE OF CONTENTS

ANNEX A. OPERATIONS

- Appendix 1-Battery Command Post
- 2-Movement and Positioning
- 3-Command and Control
- 4-Fire Direction
- 5-Survey and Meteorological Support
- 6-Firing Platoon Operations
- 7-Launcher Operations
- 8-Emergency Destruction

ANNEX B. INTELLIGENCE

ANNEX C. AIR DEFENSE

ANNEX D. NBC

- Appendix 1-NBC Operations
- 2-NBC Decontamination
- 3-MOPP
- 4-NBC Threat Warning and Alarm System

ANNEX E. SIGNAL

- Appendix 1-Radio Communications
- 2-MSE Communications

ANNEX E. SIGNAL (Continued)

- 3-Communications Security
- 4-Resynchronization

ANNEX F. COMBAT SERVICE SUPPORT

- Appendix 1-Battery Trains
- 2-Logistical Operations Center
- 3-Personnel
- 4-Supply
- 5-Ammunitions Management and Resupply Operations
- 6-Services
- 7-Unit Ministry
- 8-Maintenance Operations
- 9-Refueling Operations
- 10-Reconstitution
- 11-Medical Support

## ANNEX G. SAFETY

## ANNEX H. REPORTS

- Appendix 1-Personnel and Administration Reports  
 2-Intelligence and Security Reports  
 3-Operations Reports  
 4-Logistical Reports  
 5-NBC Reports  
 6-Communication and electronics Operations Reports

**Note:** Tabs may be used to further divide an appendix if an appendix has many subparts and is considered too lengthy. An example page number for a tab is as follows: A-1-A-1. This means page 1 of tab A to Appendix 1 of Annex A. Subsequent pages within the tab are numbered sequentially as A-1-A-2, A-1-A-3, and so forth. Tabs may be included in the table of contents.

### ANNEX A (Operations) to \_\_\_Btry, \_\_\_FA (MLRS) TSOP

This purpose of this annex is to prescribe operations within the battery.

**Appendix 1- Battery Command Post.** This appendix shows the physical setup of the battery setup of the battery CP and establishes internal CP operating procedures. Consider the following topics:

- Battery CP manning.
- Battery CP lay down with vehicles.
- BOC internal setup.
- BOC shift changeover time.
- Sleep plan.
- CP communications (internal and external).
- Specific duties and responsibilities.
- Priorities of work.
- Security.
- Load plans.

**Appendix 2- Movement and Positioning.** This appendix prescribes movement and positioning requirements, procedures, and techniques. Consider the following topics:

- Battery deployment configurations.
- Specific duties and responsibilities.
- Movement orders.
- Movement techniques and METT-T.
- Positioning in the offense.
- Positioning in the defense.
- Displacement options.
- Convoy procedures.
- Command and control during movement.
- RSOP.

**Appendix 3- Command and Control.** This appendix outlines how the battery will be commanded and controlled. Consider the following topics:

- Responsibilities for command and control.
- Orders process.
- Orders distribution.
- Orders format.
- Succession of command.
- Transfer of BOC operations.
- Alternate BOC.
- Jump BOC operations.
- ATACMS or rocket missions to selected platoons.

**Appendix 4- Fire Direction.** This appendix standardizes tactical fire direction procedures and information within the battery. Consider the following topics:

- Personnel responsibilities.
- Initialization.
- Equipment maintenance
- Communications procedures.
- Degraded mode operations procedures.
- Battery fire direction procedures.
- Platoon fire direction procedures.
- Massed fire procedures.
- Subscriber tables.

**Appendix 5- Survey and Meteorological Support.** This appendix prescribes survey operations within the battery and identifies responsibilities and procedures for receiving and disseminating meteorological messages. Consider the following topics:

- Personnel responsibilities.
- Survey priorities (for example, PADS, simultaneous observation, and hasty survey).
- SCP locations and markings.
- GPS procedures.
- Datum coordination and control.
- Extension of survey.
- Alternate met procedures in case of electronic failure.
- Met message dissemination times.
- Coordination of met requirements.

**Appendix 6- Firing Platoon Operations.** This appendix prescribes operating procedures for firing platoons. Consider the following topics:

- Platoon deployment configurations.
- Platoon OPAREA.

- POC internal setup.
- Sleep plan.
- Communications (internal and external).
- Fire direction (hot, cool, cold status; ammo status).
- Positioning (firing points, ammo supply points, survey control points, and rendezvous point).
- Specific duties and responsibilities.
- RSOP.
- Advance party configuration, equipment, and procedures.
- Security.
- Load Plans.

**Appendix 7- Launcher Operations.** This appendix prescribes operating procedures for launchers. Consider the following topics:

- Fire direction (status, response time, and startup data).
- Positioning (site selection, masking, and survey).
- Movement.
- Security.
- Specific duties and responsibilities.

**Appendix 8- Emergency Destruction.** This appendix prescribes operating procedures within the battalion. Consider the following topics:

- Specific duties and responsibilities.
- Priorities.
- Methods.
- Verification and reporting.

---

## **ANNEX B (Intelligence) to \_\_Btry, \_\_FA (MLRS) TSOP**

This annex prescribes intelligence operations within the battery. Consider the following topics:

- Specific duties and responsibilities.
- Control and destruction of classified documents.
- EPW procedures.
- Returnees.
- Security.
- Weather.
- Mapping, charting, and geodesy.
- TACJAM procedures.
- EEI.



---

## ANNEX C (Air Defense to \_\_Bn, \_\_FA (MLRS) TSOP

This annex prescribes air defense operations within the battery. Consider the following topics:

- AD procedures (active and passive).
- AD warning and weapons control status.
- Hostile aircraft criteria.
- Rules of engagement.
- Attached AD elements (C2 of and support for).

---

## ANNEX D (NBC) to \_\_Btry, \_\_FA (MLRS) TSOP

This annex provides NBC defense information and prescribes NBC operations within the battery.

**Appendix 1- NBC Operations.** This appendix prescribes NBC readiness and defense operations within the **battery**. Consider the following topics:

- Individual skills.
- NBC teams and/or control parties.
- Warning devices.
- Collective skills.
- Radiation exposure guidance.
- Unmasking procedures.
- Reporting requirements.
- Threat assessment.
- Hazard overlay.

**Appendix 2- NBC Decontamination.** This appendix establishes NBC decontamination procedures. Consider the following topics:

- Specific duties and responsibilities.
- Decontamination procedures and levels of decontamination.
- Requests for decontamination support from platoons and to higher headquarters.

**Appendix 3- MOPP.** This appendix provides easily accessible information and standardizes wear of protective clothing and use of equipment. Consider the following topics:

- MOPP levels and dissemination of MOPP.
- Standardized wear of MOPP gear (for example, name labels, and so forth).
- Requisition and issue of protective clothing and equipment.
- Location and contents of individual protective clothing and equipment bags.

**Appendix 4- NBC Threat Warning and Alarm System.** This appendix provides easily accessible information and establishes NBC threat warning and alarm procedures and priority means of dissemination within the battery.

---

## ANNEX E (Signal) to \_\_Btry,\_\_FA (MLRS) TSOP

This annex prescribes signal operations within the battery. Consider the following topics:

- Specific duties and responsibilities (battery, platoons and launchers).
- Comm integration with higher, lower, supported and adjacent units.
- Signal equipment maintenance.

**Appendix 1- Radio Communications.** This appendix provides radio comm information and prescribes radio comm procedures. Consider the following topics:

- External net diagrams.
- Internal net diagrams.
- Priority of nets.
- Specific operating and setup procedures (for example, net control, use of antennas, and so forth).

**Appendix 2- MSE Communications.** This appendix provides MSE comm information and prescribes MSE comm procedures. Consider the following topics:

- Affiliation codes and procedures.
- Disaffiliation procedures.
- RAU positioning and coverage.
- J-1077 positioning and access.
- Subscriber information.

**Appendix 3- Communications Security.** This appendix establishes comm security procedures. Consider the following topics:

- COMSEC changeover times and procedures.
- Distribution of COMSEC material.
- Loss and recovery of COMSEC material.
- SOI procedures.
- VINSON and MSRT variable control.
- Remote keying procedures.
- MSRT compromise and recovery procedures.
- GPS COMSEC.

**Appendix 4- Resynchronization.** This appendix prescribes procedures to resynchronize serialization of digital systems to correct serialization without voice transmission.

---

## ANNEX F (CSS) to \_\_Btry,\_\_FA (MLRS) TSOP

This annex prescribes CSS operations within the battery.

**Appendix 1 - Battery Trains.** This appendix shows the physical setup of the battery trains and establishes internal operating procedures. Consider the following topics:

- Specific duties and responsibilities.
- Trains area layout (vehicles and sections).

## FM 6-60

- Internal communications.
- Security.
- Movement and positioning.

**Appendix 2- Logistics Operations Center.** This appendix shows the physical setup of the LOC and establishes internal LOC operating procedures. Consider the following topics:

- Specific LOC functions.
- LOC manning.
- Shift organization and sleep plan.
- Shift changeover time and briefing procedures.
- LOC internal setup.
- C3.
- Specific duties and responsibilities.
- Priorities of work.
- Load plans.

**Appendix 3- Personnel Operations.** This appendix prescribes personnel operations within the battery to support the soldier and platoons. Consider the following topics:

- Maintenance of unit strength.
- Personnel replacement operations.
- Personnel accounting and strength reporting.
- Personnel data base management.
- Casualty management.
- Postal operations.
- EPW and CI.
- MWR.
- Other personnel functions (orders, evaluation reports, promotions, personnel actions, UCMJ, personnel assignment and utilization, and awards).

**Appendix 4- Supply Operations.** This appendix prescribes procedures to request, receive, store, and issue supplies. Consider the following topics:

- Specific duties and responsibilities.
- Management of supplies.
- Requisition flow and supply distribution (prioritize when applicable).
- All classes of supply (controlled and noncontrolled).
- Water operations, requirements, and points.
- Map supply.
- Publications and blank forms.
- Tabs for preplanned LOGPACs.
- Specific categories of supply (for example, NBC, communications, and small arms).

**Appendix 5- Ammunition Management and Resupply Operations.** This appendix prescribes ammunition management and resupply procedures. Consider the following topics:

- Specific duties and responsibilities.
- Requests.
- Resupply procedures used within the battery.

**Appendix 6- Services.** This appendix describes logistical support services. Consider the following topics:

- Laundry.
- Clothing exchange.
- Showers.
- CTA-50 exchange.
- Graves registration.

**Appendix 7- Unit Ministry Operations.** This appendix prescribes unit ministry operating procedures. Consider the following topics:

- Coordination of religious services.
- Chaplain support activities.
- Mass burial.
- Lay minister functions

**Appendix 8- Maintenance Operations.** This appendix prescribes maintenance operations within the battery. Consider the following topics:

- Specific duties and responsibilities.
- Maintenance priorities.
- Recovery and evacuation priorities.
- Cannibalization and controlled substitution.
- BDAR.
- WSRO.
- DS contact teams.
- Equipment density listing.
- Repairable and returnable components and assemblies.
- ORF.
- Equipment evacuation.
- COMSEC maintenance.

**Appendix 9- Refueling Operations.** This appendix prescribes refueling operations within the battery. Consider the following topics:

- Specific duties and responsibilities.
- Fuel request procedures and priorities.
- ROM.
- Day procedures and template.

## FM 6-60

- Night procedures and template.
- Security.
- Safety.

**Appendix 10-Reconstitution.** This appendix prescribes procedures to reconstitute the battery when it falls below an unacceptable level of combat readiness. Consider the following topics:

- Specific duties and responsibilities.
- Requirements to reconstitute (mass casualties, mass destruction of equipment, and the destruction or loss of effectiveness).
- Method of reconstitution (reorganization and regeneration).

**Appendix 11- Medical Support Operations.** This appendix prescribes medical support operations. Consider the following topics:

- Specific duties and responsibilities.
- Location of battery medic.
- Priorities for medical support.
- Communications.
- Field sanitation.
- Combat lifesaver training.
- Evacuation and reporting procedures.
- Priority of evacuation.
- Collection and accountability of individual equipment and effects.
- Treatment and prevention of disease.
- Mental health, dental, and other essential services.

---

### ANNEX G (Safety) to \_\_Btry,\_\_FA (MLRS) TSOP

This annex prescribes combat safety requirements and provides risk assessment procedures.

**Appendix 1- Safety Information and Reporting.** This appendix prescribes how command safety information will be distributed within the battery and the requirements and means for rendering accident and incident reports.

**Appendix 2- Firing Safety.** This appendix prescribes combat firing safety requirements.

---

### ANNEX H (Reports) to \_\_Btry,\_\_FA (MLRS) TSOP

This annex provides a single consolidated section within the TSOP to prescribe report requirements within the battery. Normally, reports are segregated by functional area. Reports should be tailored to specific requirements of higher headquarters and the commander's need for input into his decision-making process. Avoid requiring information that is duplicated in other reports or that is of minimal value. To the greatest extent possible, coordinate report transmission and effective times to reduce workloads and to synchronize actions. The means for submitting each report and the priority of each means must be addressed. Many reports are submitted as required and should be so indicated. Consider the reports below within this annex.

**Appendix 1- Personnel and Administration Reports.** Consider the following:

- PERSTAT report.
- Casualty feeder report.
- MEDEVAC request.

**Appendix 2- Intelligence and Security Reports.** Consider the following:

- Weather report.
- SALUTE report.
- Sensitive items report.

**Appendix 3- Operations Reports.** Consider the following:

- SITREP.
- Launcher status report.
- Voice and/or manual fire mission.
- Recon order.
- Movement order.
- Closing report.
- Request to displace.
- Ammunition assets report.

**Appendix 4- Logistical Reports.** Consider the following:

- LOGSTAT report
- Equipment status report.
- Combat loss report.
- Logistical spot report.
- Emergency resupply request (ammunition and fuel).

**Appendix 5- NBC Reports.** Consider the following:

- NBC 1 report
- NBC 2 report.
- NBC 3 report.
- NBC 4 report.
- NBC 5 report.
- NBC 6 report.
- Chemical downwind message.
- Effective downwind message.
- Request for decontamination support.
- Radiation status report.

**Appendix 6- Communications and Electronics Operations Reports.** Consider the MIJI feeder report.

## APPENDIX E

## LNO CHECKLIST

## Preparation for Operations

## EQUIPMENT

- Personal field gear and equipment.
- Camouflage screening system.
- Hex tent/stove/cots/water cans.
- Communications Systems:
  - Radios/COMSEC devices
  - OE254 Antenna
  - AN/G RA-39 Remote
  - TA-312 Telephone
  - DR-8 (w/WD-1A/TT)
- TA-1035/U with MX-10891/G field wire.
- Maps and overlay material.
- Field table with chairs.
- Office supplies and materials to include:
  - Pens/pencils/markers
  - Notepads and tablet
  - Rubbing alcohol/paper towels
  - DA Form 1594/fire mission logs

## INFORMATION

- TSOP/SOI/OPLAN/OPORD of parent unit.
- TSOP/SOI/OPLAN/OPORD of supported unit.
- Location and route to supported CP.
- Intelligence update.
- Current plans, orders, maps, overlays, and targeting information to include concept of operation and commander's intent.
- Unit locations/readiness and strength.
- Land management coordinating agency (force headquarters FSE).
- Logistical considerations and supporting agencies.
- Current status of supported unit's mission.
- References field and technical manuals.

## Liaison Operations

- Report to gaining unit S3 and brief and graphics on current status of parent unit and mission.
- Receive updated briefing and status on supported unit.
- Establish and maintain communication(s) with parent unit.
- Participate in supported unit's orders process, briefings, and rehearsals. Assist in development of:
  - FS Execution Matrix
  - FS Plan
- Advise on parent unit capabilities, requirements, limitations, and employment.
- Visit and coordinate with all supported unit staff elements.
- Send parent unit routine updates regarding mission, unit locations, future operations, and commander's intent.
- Organize sleep plan for 24-hour operations.
- Ensure supported unit S3 is aware of your location at all times.
- Accomplish mission without interfering with the supported unit's operations.
- Facilitate information exchange.

APPENDIX F

**MLRS FUNCTIONAL COMMAND POSTS**

The purpose of this appendix is to provide examples of Functional Command Posts (FCPs) for the MLRS battalion, battery, and platoon. It is a guide for the MLRS battalion commander and his staff, the MLRS battery commander and battery HQ and support personnel, and the MLRS platoon leader and platoon HQ personnel. This appendix is based on objective TOEs 06466L000 and 06467L000. The battalion FCPs in this appendix are for an MLRS battalion deployed under option 1--dual Command Posts. The battery FCPs in this appendix are for an MLRS divisional battery deployed with a split HQ. Each individual unit must adapt these FCPs to its own particular mission and deployment option and to the personnel and equipment authorized in their MTOE. For a discussion of CP functions at the battalion, battery, and platoon levels, see Chapter 4. For a consolidated list of tasks and subtasks by section, see ARTEP 6-425-MTP and ARTEP 6-398-30-MTP.

Section I

**MLRS BATTALION COMMAND POST**

**LEGEND FOR APPENDIX F**

admin	= administration	maint	= maintenance
BFVS	= Bradley fighting vehicle system	MKT	= mobile kitchen trailer
BMO	= battalion maintenance officer	MSRT	= mobile subscriber radiotelephone terminal
cdr	= commander	off	= officer
chem	= chemical	op	= operator
cmpt	= computer	ops	= operations (radio net)
CP	= command post	pers	= personnel
CPT	= captain	RATELO	= radiotelephone operator
DSVT	= digital secure voice terminal	retrans	= retransmission
FCP	= functional command post	sec	= section
FDS	= fire direction system	SPC	= specialist
gen	= generator	TOC	= tactical operation center
intel	= intelligence	TACCS	= tactical Army combat computer system
LT	= lieutenant	WO	= warrant officer
LTC	= lieutenant colonel		

**VEHICLES AT THE MLRS BATTALION CP, OPTION 1--DUAL CPs.**

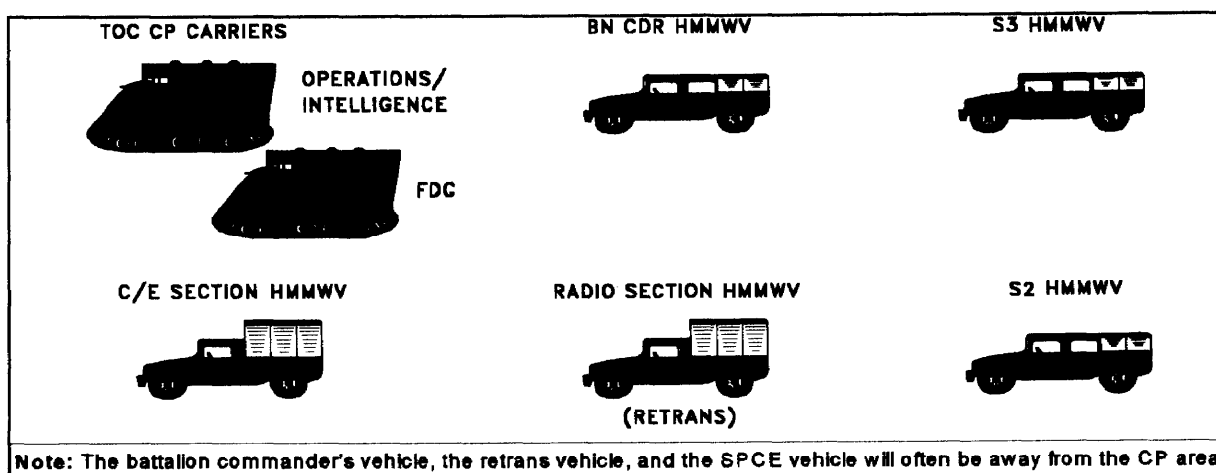

Figure F-1.



**PERSONNEL AT THE MLRS BATTALION CP, OPTION 1-DUAL CPs**

SECTION/ELEMENT POSITION	RANK	MOS	NUMBER	SHIFT A/B
--------------------------	------	-----	--------	-----------

**BATTALION HQ**

Commander	LTC	13A00	1	
Vehicle Driver	PFC	13M10	1	
Command Sergeant Major	CSM	00Z50	1	
S3	MAJ	13A00	1	
S2	CPT	13A00	1	B
Battalion Signal Officer	CPT	25C00	1	

**OPERATIONS SECTION**

Operations Officer	CPT	13A00	1	A
Chemical Officer	LT	74B00	1	A
Operations Sergeant	MSG	13Z50	1	B
NBC NCO	SSG	54B30	1	B
Carrier Driver	SPC	13P10	1	

**FIRE DIRECTION CENTER**

Battalion Fire Direction Officer	CPT	13A00	1	A
Chief Fire Direction Computer	SFC	13P40	1	B
Fire Direction Computer	SSG	13P30	1	A
Battery Display Operator	SGT	13P20	2	A/B
Fire Direction Specialist	SPC	13P10	3	A/B

**INTELLIGENCE SECTION**

Intelligence Sergeant	MSG	13Z50	1	A
Vehicle Driver	PFC	13M10	1	

**BATTALION MAINTENANCE SECTION**

Power Generator Equipment Repairman	SPC	52D10	1	
-------------------------------------	-----	-------	---	--

**MLRS BATTALION TOC SHIFTS BY DUTY POSITION**

DUTY POSITION	SHIFT A	SHIFT B
Duty Officer	Ops Off	S2
Duty NCO	Intel SGT	Ops SGT
Fire Direction	Fire Direction Officer	Chief Fire Direction Computer
Computer Operator	Fire Direction Computer	Fire Direction Specialist
NBC Operations	Chemical Officer	NBC NCO

**MLRS BATTALION TOC--SIDE-BY-SIDE CONFIGURATION**

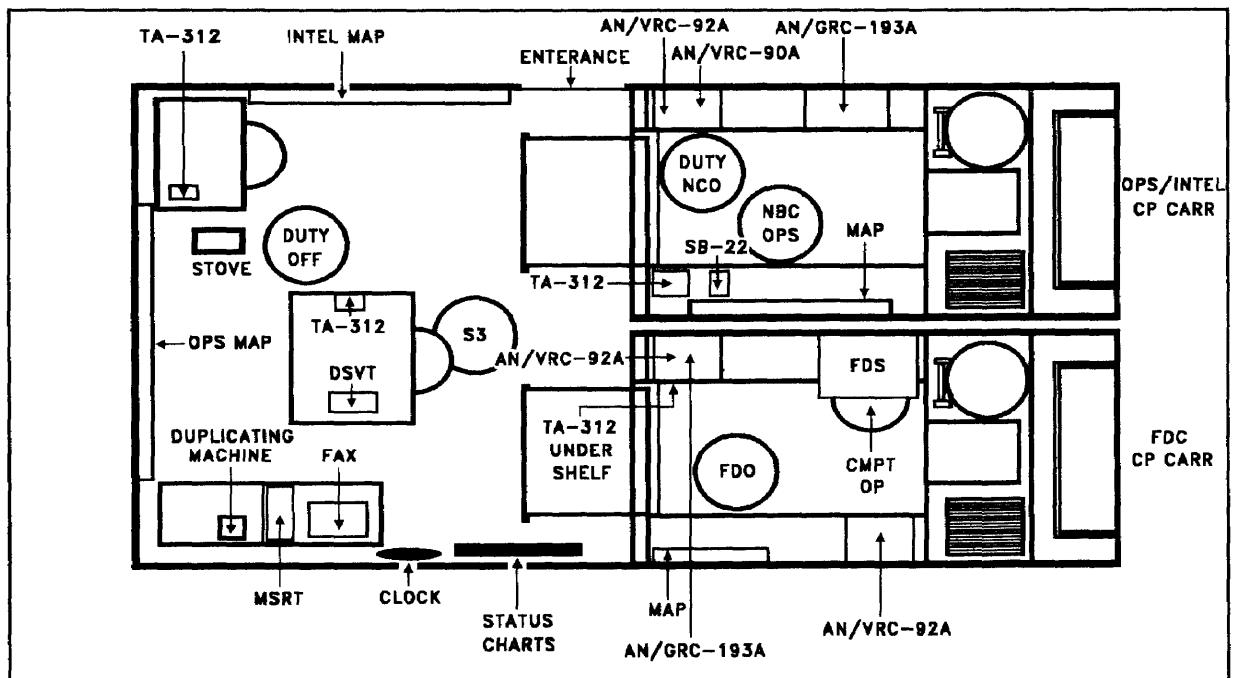

Figure F-2.

Section II  
MLRS BATTALION TRAINS

VEHICLES AT THE MLRS BATTALION TRAINS, OPTION 1-DUAL CPs

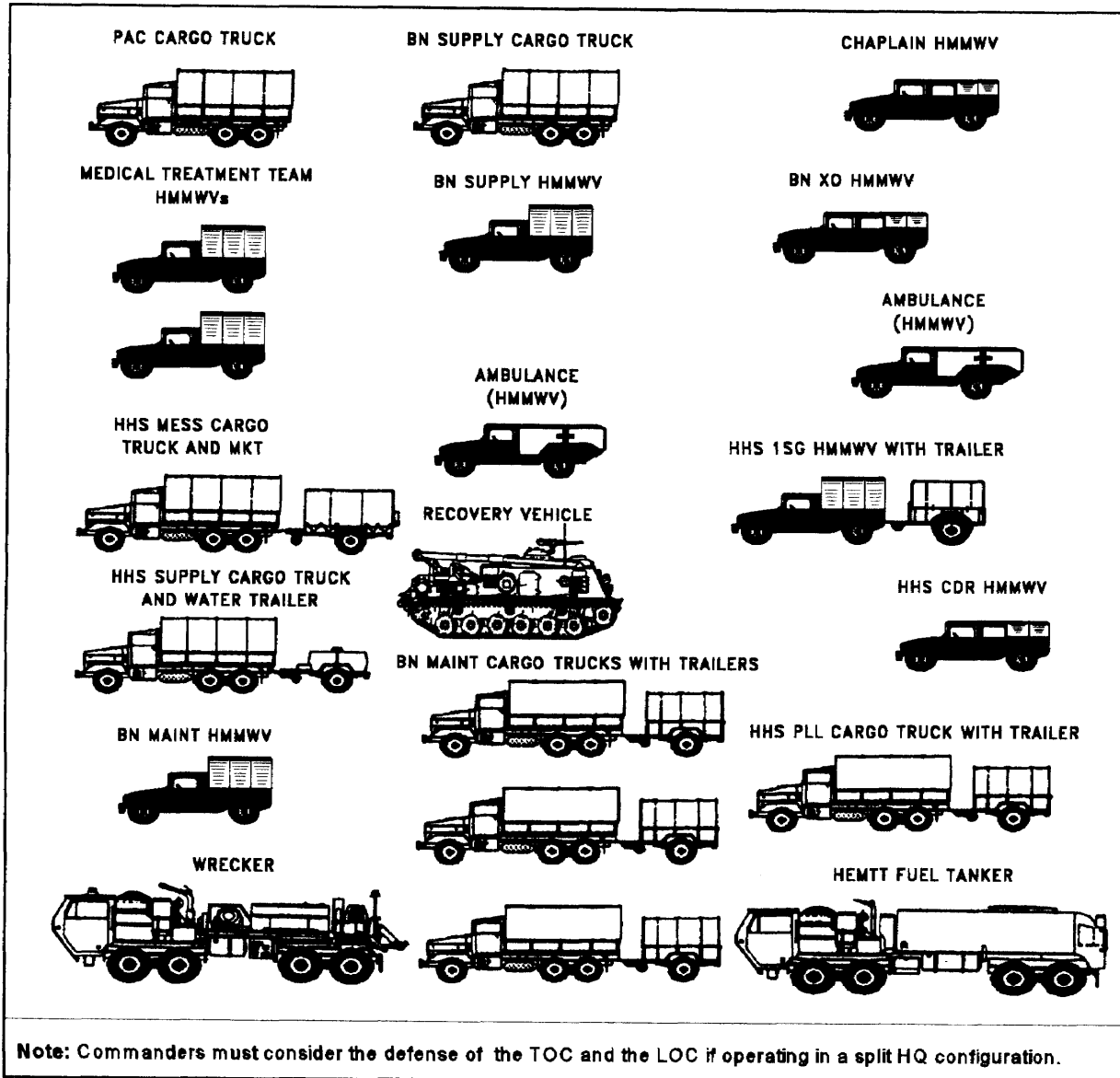

Figure F-3.

**PERSONNEL AT THE MLRS BATTALION TRAINS, OPTION 1-DUAL CPs**

SECTION/ELEMENT POSITION	RANK	MOS	NUMBER	SHIFT A/B
--------------------------	------	-----	--------	--------------

**BATTALION HQ**

Executive Officer	MAJ	13A00	1	
Chaplain	CPT	56A00	1	
S1	CPT	13A00	1	B
S4	CPT	13A00	1	A

**HHS HQ**

Commander	CPT	13A00	1	
First Sergeant	1SG	13Z5M	1	
Supply Sergeant	SGT	92Y20	1	
Armorer	SPC	92Y10	1	
Decontamination Specialist	SPC	54B10	1	
Vehicle Driver	PFC	13M10	1	

**BATTALION PAC**

Personnel Sergeant	SFC	75Z40	1	A
Personnel Administration Services Supervisor	SSG	75B30	1	B
Legal NCO	SGT	71D20	1	A
Chaplain Assistant	SPC	71M10	1	
Personnel Administration Specialist	SPC	75B10	1	B
Mail Delivery Clerk	PFC	71L10	1	A
Personnel Administration Clerk	PFC	75B10	1	A

**BATTALION SUPPLY**

Property Book Officer	W02	920AD	1	B
Battalion Supply Sergeant	SFC	92Y40	1	A
Assistant Battalion Supply NCO	SGT	92Y20	1	B
Property Book NCO	SGT	92Y20	1	A
Supply Specialist	SPC	92Y10	2	A/B
Petroleum Heavy Vehicle Operator	SPC	77F20	2	A/B

**PERSONNEL AT THE MLRS BATTALION TRAINS, OPTION 1-DUAL CPs (Continued)**

SECTION/ELEMENT POSITION	RANK	MOS	NUMBER	SHIFT A/B
--------------------------	------	-----	--------	--------------

**MEDICAL TREATMENT TEAM**

Physician Assistant	CPT	65D00	1	
Emergency Treatment NCO	SSG	91B30	1	
Medical Specialist	SPC	91B10	1	
Medical Specialist	PFC	91B10	1	

**AMBULANCE TEAM**

Aide/Evacuation NCO	SGT	91B20	1	
Ambulance Aide/Driver	SPC	91B10	1	

**HHS FOOD SERVICE SECTION**

Senior Food Operations Sergeant	SFC	92G40	1	
First Cook	SGT	92G20	1	
Cook	SPC	92G10	2	
Cook	PFC	92G10	1	

**C/E SECTION HEADQUARTERS**

Signal Support System Chief	MSG	31U50	1	
Signal Support System Maintainer	SPC	31U10	1	
Signal Information Service Specialist	SPC	31U10	1	
Signal Support System Maintainer	PFC	31U10	1	

**RADIO SECTION**

Team Chief	SGT	31U20	1	
Radio Retransmission Operator	SPC	31U10	1	
Radio Retransmission Operator	PFC	31U10	1	

**HHS MAINTENANCE SECTION**

Motor Sergeant	SSG	63B30	1	
Equipment Recovery/Parts Specialist <sup>1</sup>	SGT	92A20	1	
Light Wheeled Vehicle Mechanic	SPC	63B10	1	
Bradley Fighting Vehicle System Auto Mechanic	PFC	63T10	1	
Equipment Recovery/Parts Specialist <sup>1</sup>	PFC	92A10	1	

**PERSONNEL AT THE MLRS BATTALION TRAINS, OPTION 1-DUAL CPs (Continued)**

SECTION/ELEMENT POSITION	RANK	MOS	NUMBER	SHIFT A/B
<b>BATTALION MAINTENANCE SECTION</b>				
Battalion Maintenance Officer	CPT	13A00	1	A
Unit Maintenance Technician	WO2	915A0	1	B
Motor Sergeant	SFC	63T40	1	
Heavy Wheeled Vehicle Mechanic	SGT	63S20	1	
Light Wheeled Vehicle Mechanic	SGT	63B20	1	
Equipment Recovery/Parts Specialist <sup>1</sup>	SGT	92A20	1	A
Recovery Vehicle Operator	SGT	63T20	1	
Quartermaster and Chemical Equipment Repairman	SPC	63J10	1	
Recovery Vehicle Operator	SPC	63S10	1	
Recovery Vehicle Operator	SPC	63T10	1	
Welder	SPC	44B10	1	
Light Wheeled Vehicle Mechanic	SPC	63B10	1	
Special Field Artillery Automotive Mechanic	SPC	63D10	1	
Bradley Fighting Vehicle System Automotive Mechanic	PFC	63T10	2	
Heavy Wheeled Vehicle Mechanic	PFC	63S10	1	
Light Wheeled Vehicle Mechanic	PFC	63B10	2	
Equipment Recovery/Parts Specialist <sup>1</sup>	PFC	92A10	1	B
<b>Note:</b> <sup>1</sup> Formerly TAMMS/PLL clerk.				

**MLRS BATTALION ALOC SHIFTS BY DUTY POSITION**

DUTY POSITION	SHIFT A	SHIFT B
Duty Officer	S4	S1
Duty NCO	Personnel Sergeant	Battalion Supply NCO
Maintenance Representative	Battalion Maintenance Officer	Unit Maintenance Technician
Supply Representative	Battalion Supply Sergeant Property Book NCO	Property Book Officer Assistant Battalion Supply NCO
Personnel/Administration	Personnel/Administration Specialist	Personnel/Administration Specialist

**MLRS BATTALION ALOC IN BUILT-UP TRUCKS**

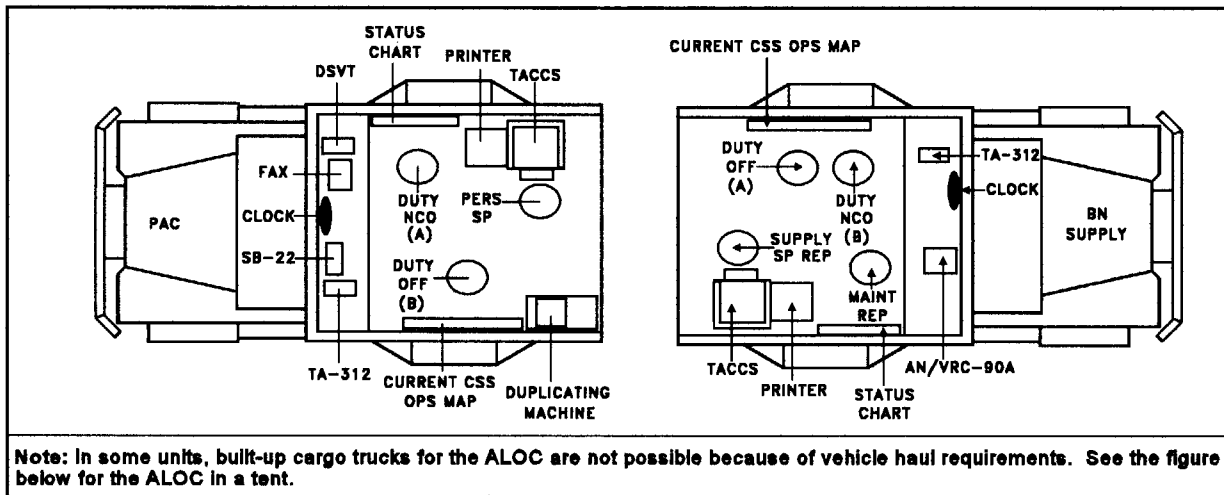

**Figure F-4.**

**MLRS BATTALION ALOC IN A GENERAL PURPOSE MEDIUM TENT**

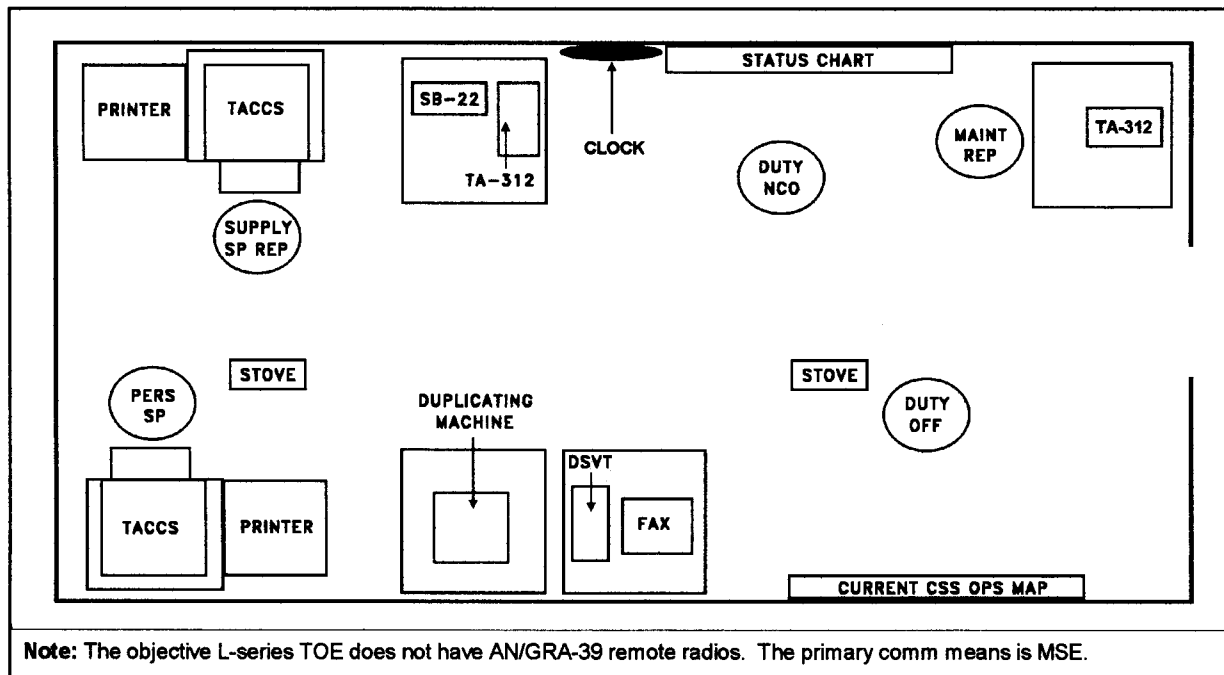

**Figure F-5.**

Section III  
**MLRS BATTERY COMMAND POST**

**DIVISIONAL MLRS BATTERY CP-SPLIT HQ**

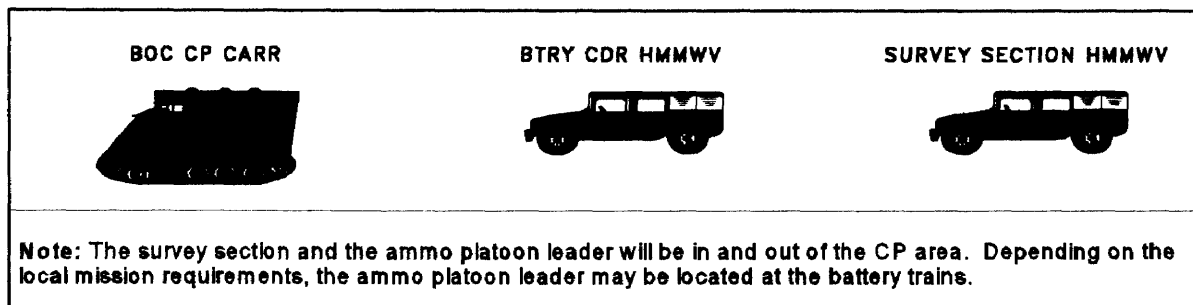

Figure F-6.

**PERSONNEL AT THE MLRS BATTERY CP-SPLIT HQ**

SECTION/ELEMENT POSITION	RANK	MOS	NUMBER	SHIFT A/B
--------------------------	------	-----	--------	--------------

**BATTERY HQ**

Battery Commander	CPT	13A00	1	
Vehicle Driver	PFC	13M10	1	
Forward Signal Support NCO (attached)	SSG	31U30	1	
NBC NCO	SSG	54B30	1	

**BATTERY OPERATIONS CENTER**

Operations Officer	1LT	13A00	1	A
Chief Fire Direction Computer (Div Btry only)	SFC	13P40	1	B
Fire Direction Computer	SSG	13P30	1	B
Fire Direction System Operator	SGT	13P20	1	A
Fire Direction Specialist	SPC	13P10	5	A/B
Signal Support System Specialist (Div Btry only)	PFC	31U10	1	



PERSONNEL AT THE MLRS BATTERY CP-SPLIT HQ (Continued)

SECTION/ELEMENT POSITION	RANK	MOS	NUMBER	SHIFT A/B
--------------------------	------	-----	--------	-----------

**SURVEY SECTION**

Section Chief	SGT	82C20	1	
Field Artillery Surveyor	SPC	82C10	1	

**MAINTENANCE SECTION**

Power Generator Equipment Repairman	SPC	52D10	1	
-------------------------------------	-----	-------	---	--

**MLRS BOC SHIFTS BY DUTY POSITION**

DUTY POSITION	SHIFT A	SHIFT B
Duty Officer	Operations Officer	Ammo Platoon Leader
Duty NCO	Fire Direction Computer or Fire Direction Computer Operator	Chief Fire Direction Computer or Fire Direction Computer
NBC Operations	NBC NCO	
Computer Operator		Fire Direction Specialist
Fire Direction Specialist	Fire Direction Specialist (2)	Fire Direction Specialist (2)

**Note:** Personnel must be cross trained to perform administrative and NBC duties.

**MLRS BATTERY OPERATIONS CENTER IN CARRIER, CP**

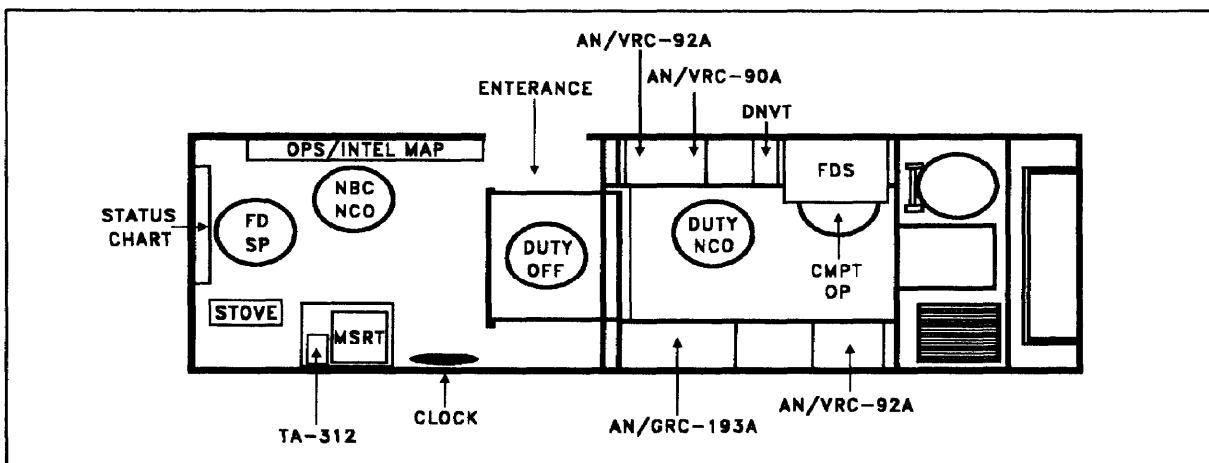

Figure F-7.

Section IV  
**MLRS BATTERY TRAINS**

**MLRS BATTERY TRAINS-SPLIT HQ**

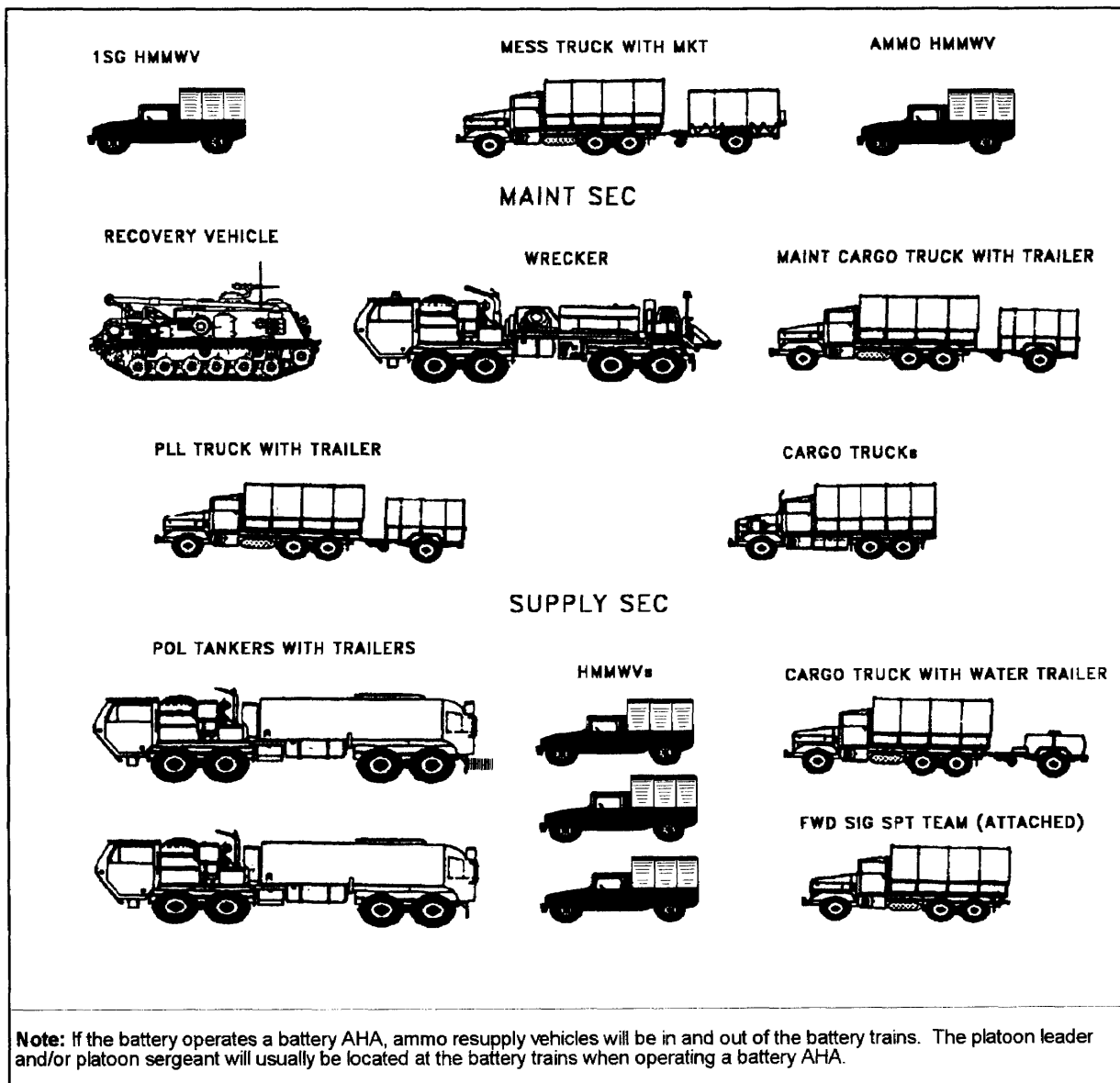

Figure F-8.

**PERSONNEL AT THE MLRS BATTERY TRAINS**

SECTION/ELEMENT POSITION	RANK	MOS	NUMBER	LOC SHIFT A/B
--------------------------	------	-----	--------	---------------

**BATTERY HQ**

First Sergeant	1SG	13Z5M	1	
Battery Signal Chief (organic to Div Btry; att to Corps Btry)	SSG	31U30	1	
Signal NCO(Div Btry only)	SGT	31U20	1	
Unit Clerk	SGT	75B20	1	B
Combat Medic (organic to Div Btry; att to Corps Btry)	SPC	91B10	1	
Signal Specialist (Div Btry only)	PFC	31U10	1	
Vehicle Driver	PFC	13M10	1	

**MAINTENANCE SECTION**

Motor Sergeant	SFC	63T40	1	
Bradley Fighting Vehicle System Mechanic	SSG	63T30	1	
Recovery Vehicle Operator	SGT	63S20	1	
Recovery Vehicle Operator	SGT	63T20	1	
Equipment Recovery/Parts Specialist <sup>1</sup>	SGT	92A20	1	A
Bradley Fighting Vehicle System Automotive Mechanic	SPC	63T10	1	
Recovery Vehicle Operator	SPC	63T10	1	
Light Wheeled Vehicle Mechanic	SPC	63B10	1	
Heavy Wheeled Vehicle Mechanic	SPC	63S10	1	
Bradley Fighting Vehicle System Mechanic	PFC	63T10	2	
Equipment Recovery/Parts Specialist <sup>1</sup>	PFC	92A10	1	B

**SUPPLY SECTION**

Supply Sergeant	SSG	92Y30	1	B
Petroleum Heavy Vehicle Operator	SGT	77F20	1	
Armorer	SPC	92Y10	1	A
Petroleum Heavy Vehicle Operator	SPC	77F10	3	
Vehicle Driver	PFC	13M10	3	

**PERSONNEL AT THE MLRS BATTERY TRAINS (Continued)**

SECTION/ELEMENT POSITION	RANK	MOS	NUMBER	LOC SHIFT A/B
--------------------------	------	-----	--------	---------------

**FOOD SERVICE SECTION**

Senior Food Operations Sergeant	SFC	92G40	1	
First Cook	SGT	92G20	1	
Cook	SPC	92G10	1	
Cook	PFC	92G10	1	

**AMMUNITION PLATOON**

Platoon Leader	1LT	13A00	1	
Platoon Sergeant	SFC	13M40	1	A

**MLRS BATTERY LOC SHIFTS BY DUTY POSITION**

DUTY POSITION	SHIFT A	SHIFT B
Duty NCO	Ammunition Platoon SGT	Supply SGT
Maintenance Representative	Equipment Recovery/Parts Specialist <sup>1</sup>	Equipment Recovery/Parts Specialist <sup>1</sup>
Clerk	Armorer	Unit Clerk

**Note:** Depending on local SOP and mission requirements, the battery first sergeant and the ammo platoon leader may be included in LOC shifts. Battery LOC could be collocated with the BOC.

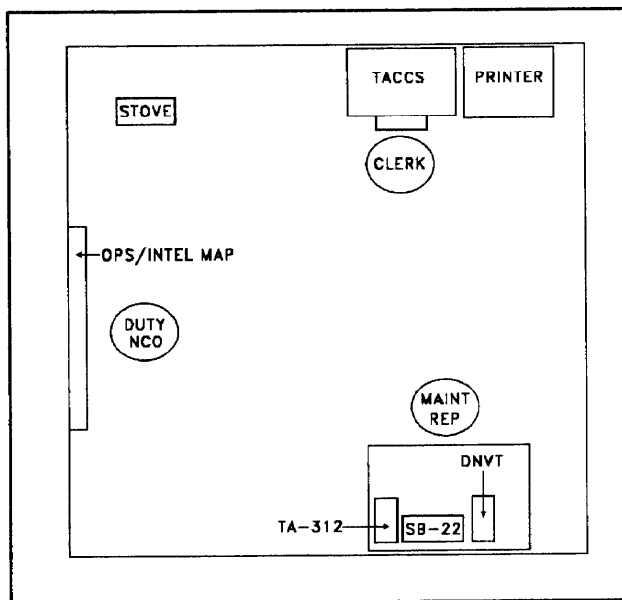

**Figure F-9.**

Section V  
**MLRS PLATOON HEADQUARTERS**

The POC is usually positioned near the center of the platoon HQ area. The platoon HQ is not usually split into a CP and a trains element like the MLRS battalion and battery may be, because the platoon HQ is not equipped and manned to do so effectively. The POC is the CP of the platoon HQ.

**VEHICLES AT THE MLRS PLATOON HQ**

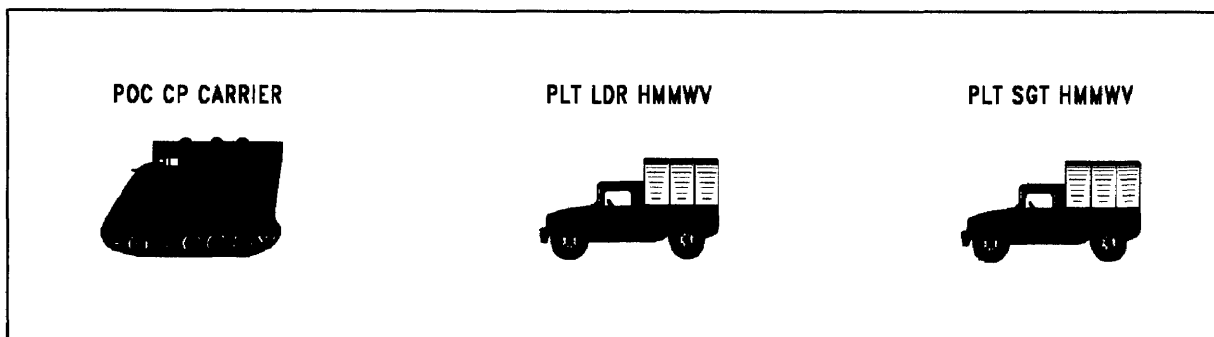

Figure F-10.

**PERSONNEL AT THE MLRS PLATOON HQ**

SECTION/ELEMENT POSITION	RANK	MOS	NUMBER	SHIFT A/B
Platoon Leader	1LT	13A00	1	A
Platoon Sergeant	SFC	13M40	1	B
Battery Display Operator	SGT	13P20	1	A
Reconnaissance Sergeant	SGT	13M20	1	
Fire Direction Specialist	SPC	13P10	1	B
Radio Operator	SPC	13M10	1	B
Fire Direction Specialist	PFC	13P10	1	A

**MLRS POC SHIFTS BY DUTY POSITION**

DUTY POSITION	SHIFT A	SHIFT B
Shift Leader	Platoon Leader	Platoon SGT
Computer Operator	Fire Direction System Operator	Fire Direction Specialist (SPC)
Radiotelephone Operator	Radio Operator	Fire Direction Specialist (PFC)

MLRS POC IN M577A2.

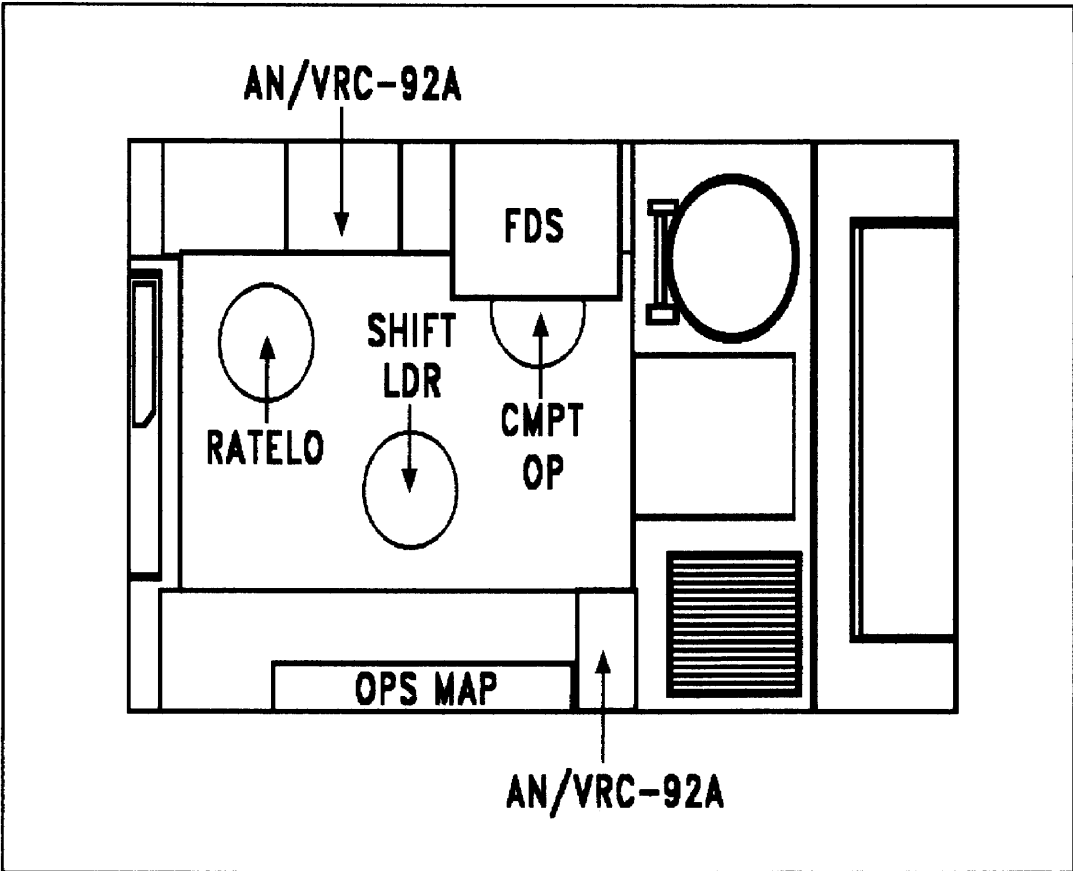

Figure F-11.

## APPENDIX G

## HASTY SURVEY TECHNIQUES-GRAPHIC RESECTION

**Description**

Graphic resection is a method of determining position based on the known locations of certain visible points. The equipment needed to perform a graphic resection includes an M2 aiming circle, a map sheet, overlay paper or acetate, and a straightedge.

**Procedures**

Select a location from which three distant points, which appear on the map, are visible. These points are well-defined vertical features, such as towers, trig markers, or church steeples.

Measure the three clockwise angles between these points with the aiming circle: first point to second point, second to third, and third point back around to the first, completing a circle around the horizon. For each angle, measure to the nearest 0.5 mil as follows:

- Set up and level the aiming circle over the proposed SCP.
- With the upper motion, set 0.0 mils on the aiming circle.
- With the lower motion, sight on the first known point.
- With the upper motion, measure the angle to the second point, and record this first reading to the nearest 0.5 mil.
- With this reading on the scales, sight again on the first point by using the lower motion.
- With the upper motion, again measure the angle to the second point. Record the second reading on the upper motion to the nearest 0.5 mil.

- Divide the second reading by 2 to determine the mean angle, which must agree with the first reading to the nearest 0.5 mil. If the first reading is more than 3,200 mils, you must add 6,400 mils to the second reading before dividing by 2. If the two readings do not agree within 0.5 mil, return to the first step.

Add the mean angles from between each point to ensure that the total sum of all three is equal to 6,400 mils  $\pm$  1.5 mil. Determine the eight-digit grid locations of the three known points from the map or a trig list, and write these beside the points.

Using the overlay paper or acetate, draw a central point, which will represent the location of the aiming circle. Using a straightedge, draw a line (first ray) outward. Using a range-deflection protractor (RDP) or a coordinate scale (less accurate), measure clockwise the number of mils corresponding to the angle between the first and second known points. Draw a line along that mil measurement from the central point outward (second ray). Do this again with the third angle, developing a third ray from the central point outward. With the third ray in place, measure from it, clockwise back to the first ray. Compare this measurement to the mean angle from the aiming circle. These two angles should agree to within  $\pm$ 0.5 mil.

Place the overlay with the three lines radiating out from the central point on the map sheet. Position it so that the first ray passes through the first known point from the map, the second through the second point, and likewise for the third. Once all three are aligned, the central point from the overlay paper represents the aiming circle map location.

Use a coordinate scale to determine the eight-digit grid of the aiming circle and the approximate elevation. Record these data for the launcher to use in updating its PDS after every 4 to 6 kilometers of travel and should not use it for calibration.

APPENDIX H

**M26/M28 ROCKET CREST CLEARANCE TABLES**

The purpose of these tables is to provide leaders a planning tool which allows them to assess the impact of intervening crests on rocket trajectories. They were developed by the MLRS project office of U.S. Army Missile Command (MICOM) for the U.S. Army Field Artillery School.

**Assumptions**

These tables establish minimum planning ranges for launchers in specific firing areas which ensure that rockets will not only clear a crest, but that warhead event will not occur until the crest is cleared. The tables use five launch altitudes: sea level, +400 m, +800 m, +1200 m, and +3048 m. They do not represent an absolute launcher ballistic algorithm and should not be used as a firing solution safety check. The tables are based on several assumptions and conditions:

- European rockets or those with lot number VGT072 or higher were used. These lots have more aerodynamic fins and therefore produce longer ranges with lower trajectories.
- A warhead event will not occur until the crest is cleared.
- Standard atmospheric conditions with 99% global wind conditions (head and tail) were applied to account for low level winds. Rockets were conditioned both cold and hot to account for temperature extremes.
- 3.3 sigma range and height dispersion errors were used to account for occasion-to-occasion (bias) and round-to-round (precision) errors.
- 100 m altitude subtracted to account for vegetation and terrain effects.
- Ballistic algorithm version 6.06 with no high QE mode.

**Procedures**

There are two entry arguments for the tables: Range (to crest) and Angle of Site (to crest). If the angle of site

cannot be directly measured, then leaders can calculate it by using the mil relation formula below:

$$\text{ANGLE OF SITE} = \frac{\text{d ALT (m)}}{\text{RANGE (km)}}$$

Where:  
**d Alt = Difference in altitude between launcher and crest (meters).**

**RANGE = Range to crest to the nearest 100m expressed in kilometers**

**Figure H-1. Mil Relation Formula**

If the *actual* target location and altitude are known, the angle of site can be modified to account for the differences in launch and target altitude using the formula below:

$$\text{Angle of Site}_{\text{eff}} = \text{Angle of Site to Crest} - \text{Angle of Site to Target}$$

Where:

$$\text{Angle of Site to Target} = \frac{\text{ALT}_{\text{TGT}}(\text{m}) - \text{ALT}_{\text{LCHR}}(\text{m})}{\text{RANGE TO TARGET}}$$

and:

**ALT<sub>TGT</sub> = Altitude of Target**

**ALT<sub>LCHR</sub> = Altitude of Launcher**

**Figure H-2. Effective angle of site.**



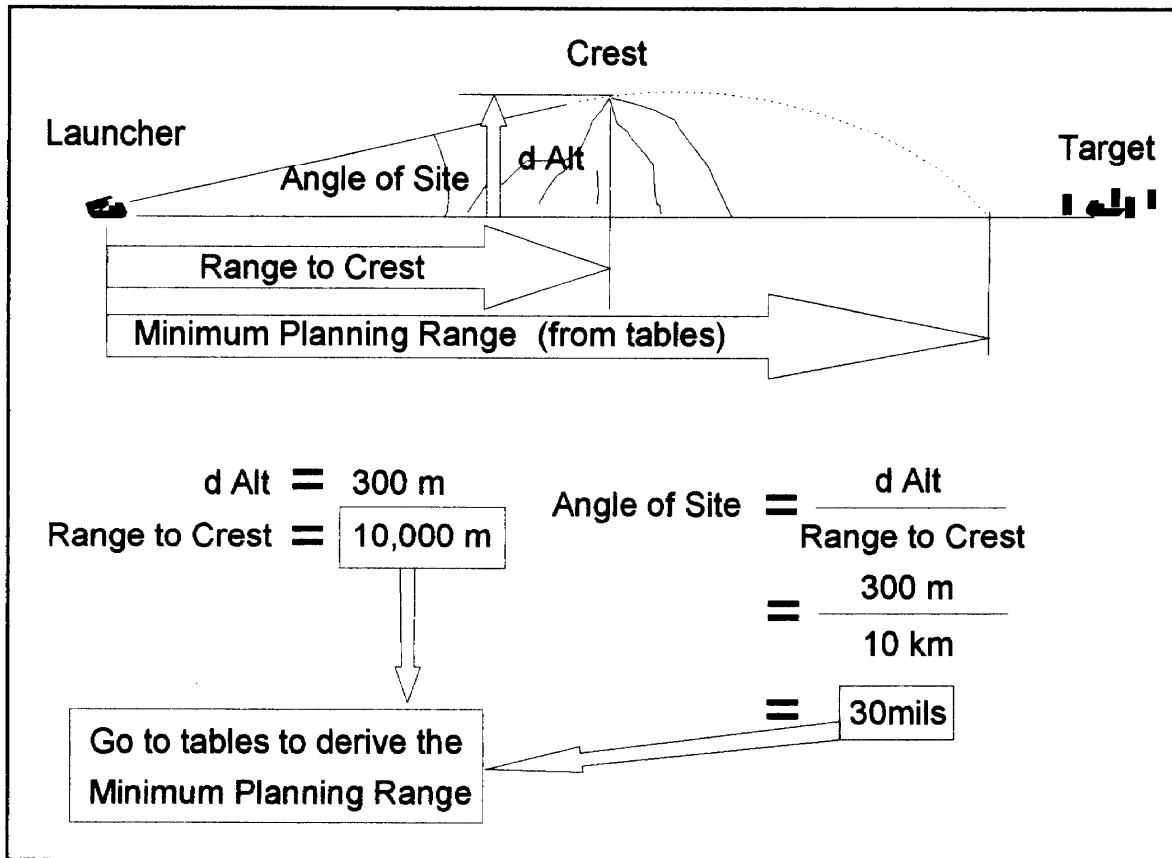

Figure H-3. Crest clearance.

**Minimum Planning Range to Clear a Crest...**

Range to Crest of (m):	Angle of Site to Crest (mils):								
	10	20	30	40	50	60	80	100	
2000	0	0	0	10100	11500	13200	14600	16000	
2500	0	0	0	0	10900	12100	14200	15500	
3000	0	<b>NO FIRING CONSTRAINT (10 km MIN RANGE)</b>			0	10300	11600	14000	15400
3500	0				0	10200	11600	13900	15300
4000	0				0	10300	11600	13900	15300
4500	0				0	10400	11700	14000	15400
5000	0	0	0	0	11100	12100	14200	15500	
5500	0	0	0	0	11300	12300	14300	15700	
6000	0	0	0	10200	11600	13000	14500	15900	
6500	0	0	0	11000	11900	13300	14700	16100	
7000	0	0	0	11200	12300	13500	15000	16300	
7500	0	0	10300	11600	12700	13800	15200	16500	
8000	0	0	11100	12000	13200	14100	15500	16800	
8500	10500	11000	11500	12300	13600	14300	15800	17000	
9000	10600	11100	12000	13200	13900	14600	16000	17200	
9500	11400	11800	12400	13500	14300	14900	16300	17500	
10000	11500	12100	13200	13900	14600	15300	16500	17800	
10500	12400	12700	13600	14300	15000	15600	16800	18000	
11000	12600	13300	14000	14700	15400	16000	17100	18200	
11500	13000	13700	14400	15100	15700	16300	17500	18500	
12000	13600	14200	14900	15500	16100	16700	17800	18800	
12500	13900	14600	15300	15900	16500	17100	18100	19200	
13000	14500	15100	15700	16300	16900	17500	18500	19600	
13500	14900	15600	16200	16800	17300	17800	18800	20000	
14000	15400	16000	16600	17200	17700	18200	19200	20200	
14500	15900	16500	17100	17600	18100	18600	19700	20500	
15000	16400	17000	17500	18000	18500	19000	20100	20800	
15500	16800	17400	17900	18400	18900	19500	20400	21200	
16000	17400	17900	18400	18900	19400	19900	20700	21500	
16500	17800	18300	18800	19300	19900	20300	21100	21900	

**FM 6-60**

***Minimum Planning Range to Clear a Crest...***

Range to Crest of (m):	Angle of Site to Crest (mils):							
	120	140	160	180	200	220	240	260
<b>2000</b>	17100	18200	19200	20100	21000	21800	22600	23400
<b>2500</b>	16800	17900	18900	19800	20700	21600	22400	23100
<b>3000</b>	16600	17700	18700	19700	20600	21500	22300	23100
<b>3500</b>	16500	17700	18700	19700	20600	21400	22300	23000
<b>4000</b>	16600	17700	18700	19700	20600	21500	22300	23100
<b>4500</b>	16600	17800	18800	19700	20700	21500	22300	23100
<b>5000</b>	16700	17900	18900	19800	20700	21600	22400	23200
<b>5500</b>	16900	18000	19000	20000	20900	21700	22500	23300
<b>6000</b>	17100	18100	19200	20100	21000	21800	22600	23400
<b>6500</b>	17200	18300	19300	20200	21100	22000	22800	23500
<b>7000</b>	17400	18500	19500	20400	21300	22100	22900	23700
<b>7500</b>	17600	18700	19700	20600	21500	22300	23100	23800
<b>8000</b>	17900	18900	19900	20800	21600	22500	23200	24000
<b>8500</b>	18100	19100	20100	21000	21800	22600	23400	24200
<b>9000</b>	18400	19400	20300	21200	22000	22800	23600	24300
<b>9500</b>	18600	19600	20500	21400	22200	23000	23800	24500
<b>10000</b>	18900	19800	20700	21600	22400	23200	24000	24700
<b>10500</b>	19000	20100	21000	21800	22700	23400	24200	24900
<b>11000</b>	19300	20300	21200	22100	22900	23700	24400	25100
<b>11500</b>	19600	20500	21400	22400	23200	23900	24600	25300
<b>12000</b>	20000	20700	21700	22600	23400	24100	24900	25600
<b>12500</b>	20200	20900	22000	22700	23600	24400	25100	25800
<b>13000</b>	20500	21200	22100	22900	23900	24600	25300	26000
<b>13500</b>	20700	21500	22300	23100	24100	24700	25500	26300
<b>14000</b>	21000	21800	22600	23400	24200	24800	25800	26600
<b>14500</b>	21300	22100	22900	23600	24400	25100	26000	26800
<b>15000</b>	21600	22400	23200	23900	24600	25400	26100	27100
<b>15500</b>	22000	22800	23500	24200	24900	25600	26300	27100
<b>16000</b>	22300	23100	23800	24500	25200	25900	26600	27200
<b>16500</b>	22700	23400	24200	24900	25500	26200	26900	27500

**Minimum Planning Range to Clear a Crest...**

Range to Crest of (m):	Angle of Site to Crest (mils):							
	10	20	30	40	50	60	80	100
<b>17000</b>	18300	18800	19300	19800	20300	20700	21500	22300
<b>17500</b>	18700	19300	19800	20200	20600	21000	21900	22600
<b>18000</b>	19300	19800	20200	20600	21100	21500	22300	23000
<b>18500</b>	19700	20200	20700	21100	21500	21900	22700	23400
<b>19000</b>	20400	20700	21100	21500	21900	22300	23100	23800
<b>19500</b>	20600	21200	21600	22000	22400	22700	23500	24200
<b>20000</b>	21300	21700	22000	22400	22800	23200	23900	24600
<b>20500</b>	21600	22100	22500	22900	23200	23600	24300	25000
<b>21000</b>	22300	22600	23000	23300	23700	24000	24700	25400
<b>21500</b>	22500	23100	23400	23800	24100	24500	25200	25800
<b>22000</b>	23200	23500	23900	24200	24600	24900	25600	26200
<b>22500</b>	23500	24000	24400	24700	25000	25400	26000	26700
<b>23000</b>	24200	24500	24800	25200	25500	25800	26500	27100
<b>23500</b>	24500	25000	25300	25600	26000	26300	26900	27500
<b>24000</b>	25300	25500	25800	26100	26400	26700	27300	28000
<b>24500</b>	25500	25900	26300	26600	26900	27200	27800	28400
<b>25000</b>	26100	26400	26700	27000	27300	27600	28200	28800
<b>25500</b>	26400	26900	27200	27500	27800	28100	28700	29300
<b>26000</b>	27100	27400	27700	28000	28300	28600	29100	29700
<b>26500</b>	27400	27800	28200	28500	28700	29000	29600	30200
<b>27000</b>	28100	28400	28700	28900	29200	29500	30100	30800
<b>27500</b>	28400	28800	29100	29400	29700	30000	30600	31200
<b>28000</b>	29100	29300	29600	29900	30200	30500	31100	31600
<b>28500</b>	30200	30300	30500	30700	30900	31000	31500	32000
<b>29000</b>	30200	30500	30700	31000	31200	31400	31900	0
<b>29500</b>	30400	30800	31100	31400	31600	31900	0	0
<b>30000</b>	31200	31400	31600	31900	0	0	0	0
<b>30500</b>	31400	31800	0	0	0	0	0	0
<b>31000</b>	0	0	0	0	0	0	0	0
<b>31500</b>	0	0	0	0	0	0	0	0

**ALT: Sea Level**

**FM 6-60**

**Minimum Planning Range to Clear a Crest...**

Range to Crest of (m):	Angle of Site to Crest (mils):							
	120	140	160	180	200	220	240	260
17000	23000	23800	24500	25200	25900	26500	27200	27800
17500	23400	24100	24800	25500	26200	26800	27500	28100
18000	23800	24500	25200	25800	26500	27100	27800	28400
18500	24100	24800	25500	26200	26800	27500	28100	28700
19000	24500	25200	25900	26500	27200	27800	28400	29000
19500	24900	25600	26200	26900	27500	28100	28700	29300
20000	25300	26000	26600	27200	27900	28500	29100	29600
20500	25700	26300	27000	27600	28200	28800	29400	30000
21000	26100	26700	27400	28000	28600	29200	29700	30600
21500	26500	27100	27700	28300	28900	29500	30200	31100
22000	26900	27500	28100	28700	29300	29900	30800	31300
22500	27300	27900	28500	29100	29700	30400	31200	31500
23000	27700	28300	28900	29500	30100	31000	31400	31800
23500	28100	28700	29300	29900	30700	31300	31700	0
24000	28500	29100	29700	30400	31100	31500	32000	0
24500	29000	29500	30200	31000	31400	31800	0	0
25000	29400	30000	30800	31300	31700	0	0	0
25500	29800	30600	31200	31600	32000	0	0	0
26000	30400	31100	31500	31900	0	0	0	0
26500	30900	31400	31800	0	0	0	0	0
27000	31300	31800	0	0	0	0	0	0
27500	31700	0	0	0	0	0	0	0
28000	0	0	0	0	0	0	0	0
28500	0	0	0	0	0	0	0	0
29000	0	0	0	MAX RANGE FAILS TO CLEAR CREST (32 km)			0	0
29500	0	0	0				0	0
30000	0	0	0	0	0	0	0	0
30500	0	0	0	0	0	0	0	0
31000	0	0	0	0	0	0	0	0
31500	0	0	0	0	0	0	0	0

**Minimum Planning Range to Clear a Crest...**

Range to Crest of (m):	Angle of Site to Crest (mils):								
	10	20	30	40	50	60	80	100	
2000	0	0	0	10400	11900	13400	15000	16300	
2500	0	0	0	0	11200	12200	14500	15900	
3000	0	<b>NO FIRING CONSTRAINT (10 km MIN RANGE)</b>			0	10600	12000	14300	15700
3500	0				0	10500	11900	14200	15600
4000	0				0	10500	12000	14200	15600
4500	0				0	11000	12100	14300	15700
5000	0	0	0	0	11300	12200	14400	15800	
5500	0	0	0	10100	11500	12500	14600	16000	
6000	0	0	0	10500	11800	13200	14800	16200	
6500	0	0	0	11100	12100	13500	15000	16400	
7000	0	0	10100	11400	12400	13800	15300	16600	
7500	0	0	10500	11800	13100	14100	15500	16800	
8000	0	0	11200	12200	13500	14300	15800	17100	
8500	10500	11100	11700	12600	13500	14600	16100	17300	
9000	10600	11200	12200	13000	14100	14900	16400	17600	
9500	10800	11800	12600	13400	14500	15200	16600	17700	
10000	11500	12200	13300	14100	14800	15500	16800	18000	
10500	12400	12900	13800	14500	15200	15900	17100	18300	
11000	12600	13400	14200	14900	15600	16200	17400	18600	
11500	13400	13900	14600	15300	16000	16600	17700	18800	
12000	13600	14300	15000	15700	16300	17000	18100	19100	
12500	14400	14900	15500	16100	16700	17300	18400	19400	
13000	14600	15200	15900	16500	17100	17700	18800	19800	
13500	15400	15800	16300	16900	17500	18100	19100	20100	
14000	15600	16200	16800	17400	17900	18500	19500	20400	
14500	16400	16800	17200	17800	18300	18900	19800	20800	
15000	16500	17100	17700	18200	18700	19200	20200	21100	
15500	17400	17700	18100	18600	19100	19600	20600	21500	
16000	17500	18000	18500	19100	19500	20000	21000	21800	
16500	18300	18700	19000	19500	20000	20400	21300	22200	

**FM 6-60**

***Minimum Planning Range to Clear a Crest...***

Range to Crest of (m):	Angle of Site to Crest (mils):							
	120	140	160	180	200	220	240	260
<b>2000</b>	17500	18600	19600	20600	21500	22400	23200	24000
<b>2500</b>	17100	18300	19300	20300	21200	22100	23000	23700
<b>3000</b>	17000	18100	19200	20200	21100	22000	22800	23600
<b>3500</b>	16900	18100	19100	20100	21100	22000	22800	23600
<b>4000</b>	16900	18100	19200	20200	21100	22000	22800	23600
<b>4500</b>	17000	18200	19200	20200	21200	22100	22900	23700
<b>5000</b>	17100	18300	19300	20300	21200	22100	23000	23800
<b>5500</b>	17200	18400	19400	20400	21400	22200	23100	23900
<b>6000</b>	17400	18500	19600	20600	21500	22400	23200	24000
<b>6500</b>	17600	18700	19700	20700	21600	22500	23300	24100
<b>7000</b>	17800	18900	19900	20900	21800	22700	23500	24300
<b>7500</b>	18000	19100	20100	21100	22000	22800	23600	24400
<b>8000</b>	18200	19300	20300	21200	22100	23000	23800	24600
<b>8500</b>	18500	19500	20500	21400	22300	23200	24000	24800
<b>9000</b>	18700	19800	20700	21600	22500	23400	24200	24900
<b>9500</b>	19000	20000	20900	21900	22700	23600	24400	25100
<b>10000</b>	19200	20200	21200	22100	22900	23800	24600	25300
<b>10500</b>	19400	20500	21400	22300	23200	24000	24800	25500
<b>11000</b>	19600	20700	21700	22600	23400	24200	25000	25700
<b>11500</b>	19800	21000	21900	22800	23700	24400	25200	26000
<b>12000</b>	20100	21200	22000	23100	23900	24700	25400	26200
<b>12500</b>	20400	21300	22300	23300	24100	24900	25700	26400
<b>13000</b>	20700	21600	22500	23400	24300	25200	26000	26700
<b>13500</b>	21000	21900	22800	23600	24500	25400	26200	26900
<b>14000</b>	21300	22200	23000	23800	24700	25500	26300	27200
<b>14500</b>	21700	22500	23300	24100	24900	25600	26500	27400
<b>15000</b>	22000	22800	23600	24400	25100	25900	26700	27600
<b>15500</b>	22300	23200	23900	24700	25400	26100	26900	27900
<b>16000</b>	22700	23500	24300	25000	25700	26400	27100	28000
<b>16500</b>	23000	23800	24600	25300	26000	26700	27400	28100

**ALT: 400 m ASL**

**Minimum Planning Range to Clear a Crest...**

Range to Crest of (m):	Angle of Site to Crest (mils):							
	10	20	30	40	50	60	80	100
<b>17000</b>	18500	18900	19400	19900	20400	20800	21700	22600
<b>17500</b>	19300	19600	19900	20400	20800	21300	22100	22900
<b>18000</b>	19400	19900	20300	20800	21200	21700	22500	23300
<b>18500</b>	19800	20300	20800	21200	21700	22100	22900	23700
<b>19000</b>	20300	20800	21300	21700	22100	22500	23300	24100
<b>19500</b>	20700	21300	21700	22100	22500	22900	23700	24500
<b>20000</b>	21300	21800	22200	22600	23000	23400	24100	24900
<b>20500</b>	21700	22200	22600	23000	23400	23800	24600	25300
<b>21000</b>	22300	22700	23100	23500	23900	24200	25000	25700
<b>21500</b>	22600	23200	23600	23900	24300	24700	25400	26100
<b>22000</b>	23300	23700	24000	24400	24800	25100	25800	26500
<b>22500</b>	23600	24100	24500	24900	25200	25600	26300	27000
<b>23000</b>	24300	24600	25000	25300	25700	26000	26700	27400
<b>23500</b>	24600	25100	25400	25800	26100	26500	27100	27800
<b>24000</b>	25200	25600	25900	26300	26600	26900	27600	28200
<b>24500</b>	25500	26100	26400	26700	27100	27400	28000	28700
<b>25000</b>	26300	26500	26900	27200	27500	27800	28500	29100
<b>25500</b>	26500	27000	27300	27700	28000	28300	28900	29500
<b>26000</b>	27300	27600	27800	28100	28400	28800	29400	30000
<b>26500</b>	27500	28000	28300	28600	28900	29200	29800	30400
<b>27000</b>	28200	28500	28800	29100	29400	29700	30300	30900
<b>27500</b>	28500	28900	29300	29600	29900	30100	30700	31300
<b>28000</b>	29300	29500	29800	30000	30300	30600	31200	31800
<b>28500</b>	29500	29900	30200	30500	30800	31100	31700	0
<b>29000</b>	30100	30400	30700	31000	31300	31600	0	0
<b>29500</b>	30500	30900	31200	31500	31800	0	0	0
<b>30000</b>	31200	31400	31700	32000	0	0	0	0
<b>30500</b>	31500	31900	0	0	0	0	0	0
<b>31000</b>	0	0	0	0	0	0	0	0
<b>31500</b>	0	0	0	0	0	0	0	0



**FM 6-60**

**Minimum Planning Range to Clear a Crest...**

Range to Crest of (m):	Angle of Site to Crest (mils):							
	120	140	160	180	200	220	240	260
17000	23400	24200	24900	25600	26300	27000	27700	28400
17500	23700	24500	25200	26000	26700	27300	28000	28700
18000	24100	24900	25600	26300	27000	27700	28300	29000
18500	24500	25200	25900	26600	27300	28000	28600	29300
19000	24800	25600	26300	27000	27700	28300	29000	29600
19500	25200	25900	26600	27300	28000	28600	29300	29900
20000	25600	26300	27000	27700	28300	29000	29600	30200
20500	26000	26700	27400	28000	28700	29300	29900	30600
21000	26400	27100	27800	28400	29100	29700	30300	30900
21500	26800	27500	28100	28800	29400	30000	30600	31200
22000	27200	27900	28500	29200	29800	30400	31000	31600
22500	27600	28300	28900	29500	30200	30800	31400	31900
23000	28000	28700	29300	29900	30500	31100	31700	0
23500	28400	29100	29700	30300	30900	31500	0	0
24000	28900	29500	30100	30700	31300	31900	0	0
24500	29300	29900	30500	31100	31700	0	0	0
25000	29700	30300	30900	31500	0	0	0	0
25500	30100	30700	31300	31900	0	0	0	0
26000	30600	31200	31800	0	0	0	0	0
26500	31000	31600	0	0	0	0	0	0
27000	31500	0	0	0	0	0	0	0
27500	31900	0	0	0	0	0	0	0
28000	0	0	0	0	0	0	0	0
28500	0	0	0	0	0	0	0	0
29000	0	0	0	MAX RANGE FAILS TO CLEAR CREST (32 km)			0	0
29500	0	0	0				0	0
30000	0	0	0	0	0	0	0	0
30500	0	0	0	0	0	0	0	0
31000	0	0	0	0	0	0	0	0
31500	0	0	0	0	0	0	0	0

**Minimum Planning Range to Clear a Crest..**

Range to Crest of (m):	Angle of Site to Crest (mils):							
	10	20	30	40	50	60	80	100
2000	0	0	0	10600	11700	13600	15300	16700
2500	0	0	0	0	11200	12300	14800	16200
3000	0	<b>NO FIRING CONSTRAINT (10 km MIN RANGE)</b>		0	10800	11800	14600	16000
3500	0			0	10700	11800	14500	16000
4000	0			0	10800	11800	14500	16000
4500	0			0	11000	11900	14600	16100
5000	0	0	0	11200	12100	14700	16200	
5500	0	0	0	10100	11400	12600	14900	16300
6000	0	0	0	10600	11700	13300	15100	16500
6500	0	0	0	11100	12000	13600	15300	16700
7000	0	0	0	11400	12400	14000	15600	16900
7500	0	0	10500	11600	13200	14300	15800	17200
8000	0	0	11100	12000	13500	14500	16100	17400
8500	0	10400	11500	12400	14000	14900	16300	17700
9000	10800	11600	12400	13100	14400	15200	16600	17900
9500	10900	11800	12700	13900	14700	15400	16900	18200
10000	11600	12400	13300	14300	15100	15800	17200	18400
10500	12400	12900	13900	14700	15400	16100	17400	18600
11000	12600	13300	14400	15100	15800	16500	17700	18800
11500	13500	14000	14800	15500	16200	16800	18100	19200
12000	13700	14500	15200	15900	16600	17200	18400	19500
12500	14500	15000	15600	16300	17000	17600	18700	19800
13000	14700	15400	16100	16700	17400	18000	19100	20100
13500	15100	15800	16500	17100	17700	18300	19400	20400
14000	15700	16300	17000	17600	18200	18700	19800	20800
14500	16100	16800	17400	18000	18500	19100	20100	21100
15000	16600	17200	17800	18400	19000	19500	20500	21500
15500	17100	17700	18300	18800	19400	19900	20900	21800
16000	17600	18200	18700	19200	19800	20300	21200	22200
16500	18100	18600	19200	19700	20200	20700	21600	22500

**FM 6-60**

**Minimum Planning Range to Clear a Crest...**

Range to Crest of (m):	Angle of Site to Crest (mils):							
	120	140	160	180	200	220	240	260
<b>2000</b>	17900	19100	20100	21100	22100	23000	23800	24600
<b>2500</b>	17500	18700	19800	20800	21800	22700	23500	24400
<b>3000</b>	17300	18500	19600	20700	21600	22600	23400	24300
<b>3500</b>	17300	18500	19600	20600	21600	22500	23400	24200
<b>4000</b>	17300	18500	19600	20600	21600	22500	23400	24300
<b>4500</b>	17400	18600	19700	20700	21700	22600	23500	24300
<b>5000</b>	17500	18700	19800	20800	21800	22700	23600	24400
<b>5500</b>	17600	18800	19900	20900	21900	22800	23700	24500
<b>6000</b>	17800	18900	20000	21000	22000	22900	23800	24600
<b>6500</b>	18000	19100	20200	21200	22100	23100	23900	24700
<b>7000</b>	18200	19300	20400	21400	22300	23200	24100	24900
<b>7500</b>	18400	19500	20500	21500	22500	23400	24200	25100
<b>8000</b>	18600	19700	20800	21700	22700	23600	24400	25200
<b>8500</b>	18900	19900	21000	21900	22900	23700	24600	25400
<b>9000</b>	19100	20200	21200	22100	23000	23900	24800	25600
<b>9500</b>	19300	20400	21400	22400	23300	24100	25000	25800
<b>10000</b>	19500	20700	21600	22600	23500	24300	25200	26000
<b>10500</b>	19800	20900	21900	22800	23700	24500	25400	26200
<b>11000</b>	20100	21100	22200	23100	23900	24800	25600	26400
<b>11500</b>	20300	21300	22400	23300	24200	25000	25800	26600
<b>12000</b>	20500	21600	22600	23500	24400	25200	26100	26800
<b>12500</b>	20800	21800	22800	23800	24700	25500	26300	27100
<b>13000</b>	21100	22000	22900	24100	24900	25800	26500	27300
<b>13500</b>	21400	22300	23200	24300	25200	26000	26800	27600
<b>14000</b>	21700	22600	23500	24500	25500	26300	27100	27900
<b>14500</b>	22000	22900	23800	24700	25600	26400	27400	28100
<b>15000</b>	22400	23200	24100	24900	25700	26700	27500	28300
<b>15500</b>	22700	23500	24400	25200	25900	26900	27600	28500
<b>16000</b>	23000	23900	24700	25500	26300	27100	27700	28700
<b>16500</b>	23400	24200	25000	25800	26500	27300	28000	28900

**Minimum Planning Range to Clear a Crest...**

Range to Crest of (m):	Angle of Site to Crest (mils):							
	10	20	30	40	50	60	80	100
<b>17000</b>	18500	19100	19600	20100	20600	21100	22000	22900
<b>17500</b>	19000	19500	20100	20500	21000	21500	22400	23300
<b>18000</b>	19500	20000	20500	21000	21500	21900	22800	23600
<b>18500</b>	19900	20500	21000	21400	21900	22300	23200	24000
<b>19000</b>	20500	20900	21400	21900	22300	22700	23600	24400
<b>19500</b>	20900	21400	21900	22300	22700	23200	24000	24800
<b>20000</b>	21400	21900	22300	22800	23200	23600	24400	25200
<b>20500</b>	21800	22400	22800	23200	23600	24000	24800	25600
<b>21000</b>	22400	22800	23200	23700	24100	24500	25200	26000
<b>21500</b>	22800	23300	23700	24100	24500	24900	25700	26400
<b>22000</b>	23400	23800	24200	24600	25000	25300	26100	26800
<b>22500</b>	23700	24200	24600	25000	25400	25800	26500	27200
<b>23000</b>	24300	24700	25100	25500	25900	26200	27000	27700
<b>23500</b>	24700	25200	25600	26000	26300	26700	27400	28100
<b>24000</b>	25300	25700	26100	26400	26800	27100	27800	28500
<b>24500</b>	25700	26200	26500	26900	27200	27600	28300	29000
<b>25000</b>	26300	26700	27000	27400	27700	28000	28700	29400
<b>25500</b>	26600	27100	27500	27800	28200	28500	29200	29800
<b>26000</b>	27300	27600	28000	28300	28600	29000	29600	30300
<b>26500</b>	27600	28100	28400	28800	29100	29400	30100	30700
<b>27000</b>	28300	28600	28900	29200	29600	29900	30500	31200
<b>27500</b>	28600	29100	29400	29700	30000	30400	31000	31600
<b>28000</b>	29300	29600	29900	30200	30500	30800	31500	0
<b>28500</b>	29500	30100	30400	30700	31000	31300	31900	0
<b>29000</b>	30200	30600	30900	31200	31500	31800	0	0
<b>29500</b>	30600	31100	31400	31700	32000	0	0	0
<b>30000</b>	31300	31600	31900	0	0	0	0	0
<b>30500</b>	31600	0	0	0	0	0	0	0
<b>31000</b>	0	0	0	0	0	0	0	0
<b>31500</b>	0	0	0	0	0	0	0	0

**ALT: 800 m ASL**

**FM 6-60**

**Minimum Planning Range to Clear a Crest...**

Range to Crest of (m):	Angle of Site to Crest (mils):							
	120	140	160	180	200	220	240	260
	<b>ALT: 800 m ASL</b>							
<b>17000</b>	23700	24600	25300	26100	26900	27600	28300	29000
<b>17500</b>	24100	24900	25700	26400	27200	27900	28600	29300
<b>18000</b>	24500	25300	26000	26800	27500	28200	28900	29600
<b>18500</b>	24800	25600	26400	27100	27800	28500	29200	29900
<b>19000</b>	25200	26000	26700	27400	28200	28800	29500	30200
<b>19500</b>	25600	26300	27100	27800	28500	29200	29800	30500
<b>20000</b>	26000	26700	27400	28100	28800	29500	30200	30800
<b>20500</b>	26400	27100	27800	28500	29200	29900	30500	31200
<b>21000</b>	26700	27500	28200	28900	29500	30200	30900	31500
<b>21500</b>	27100	27900	28600	29200	29900	30600	31200	31800
<b>22000</b>	27500	28300	28900	29600	30300	30900	31600	0
<b>22500</b>	28000	28600	29300	30000	30600	31300	31900	0
<b>23000</b>	28400	29000	29700	30400	31000	31700	0	0
<b>23500</b>	28800	29400	30100	30800	31400	32000	0	0
<b>24000</b>	29200	29900	30500	31200	31800	0	0	0
<b>24500</b>	29600	30300	30900	31600	0	0	0	0
<b>25000</b>	30000	30700	31300	32000	0	0	0	0
<b>25500</b>	30500	31100	31800	0	0	0	0	0
<b>26000</b>	30900	31600	0	0	0	0	0	0
<b>26500</b>	31400	32000	0	0	0	0	0	0
<b>27000</b>	31800	0	0	0	0	0	0	0
<b>27500</b>	0	0	0	0	0	0	0	0
<b>28000</b>	0	0	0	0	0	0	0	0
<b>28500</b>	0	0	0	0	0	0	0	0
<b>29000</b>	0	0	0	<b>MAX RANGE FAILS TO CLEAR CREST (32 km)</b>			0	0
<b>29500</b>	0	0	0				0	0
<b>30000</b>	0	0	0	0	0	0	0	0
<b>30500</b>	0	0	0	0	0	0	0	0
<b>31000</b>	0	0	0	0	0	0	0	0
<b>31500</b>	0	0	0	0	0	0	0	0

**Minimum Planning Range to Clear a Crest...**

Range to Crest of (m):	Angle of Site to Crest (mils):							
	10	20	30	40	50	60	80	100
2000	0	0	0	11100	12500	14000	15600	17000
2500	0	0	0	0	11700	13000	15100	16600
3000	0	<b>NO FIRING CONSTRAINT (10 km MIN RANGE)</b>		0	11200	12600	14900	16400
3500	0			0	11100	12500	14800	16300
4000	0			0	11200	12600	14800	16300
4500	0			0	11300	12700	14900	16400
5000	0	0	0	0	11600	12900	15000	16500
5500	0	0	0	10000	12100	13100	15200	16700
6000	0	0	0	11000	12400	13400	15400	16900
6500	0	0	0	11300	12700	14000	15600	17100
7000	0	0	0	12100	13000	14300	15900	17300
7500	0	0	10900	12300	13200	14600	16100	17500
8000	0	0	11300	12700	13800	14900	16400	17800
8500	0	10300	12100	13000	14300	15200	16600	18000
9000	10700	11300	12600	13400	14600	15400	16800	18300
9500	11600	12200	13000	14100	15000	15700	17100	18500
10000	11700	12600	13400	14500	15300	16000	17400	18700
10500	12400	13000	14100	14900	15700	16400	17700	19000
11000	12700	13500	14500	15300	16000	16700	18000	19200
11500	13600	14200	15000	15700	16400	17100	18300	19500
12000	13800	14600	15400	16100	16800	17400	18700	19800
12500	14500	15100	15800	16500	17200	17800	19000	20100
13000	14800	15500	16300	16900	17600	18200	19300	20400
13500	15400	16000	16700	17300	18000	18600	19700	20800
14000	15700	16500	17100	17800	18400	19000	20100	21100
14500	16400	16900	17600	18200	18800	19300	20400	21400
15000	16600	17400	18000	18600	19200	19700	20800	21800
15500	17200	17800	18400	19000	19600	20100	21200	22100
16000	17600	18300	18900	19400	20000	20500	21500	22500
16500	18200	18700	19300	19900	20400	20900	21900	22900

**FM 6-60**

**Minimum Planning Range to Clear a Crest...**

Range to Crest of (m):	Angle of Site to Crest (mils):							
	120	140	160	180	200	220	240	260
2000	18300	19500	20600	21600	22600	23500	24400	25200
2500	17900	19100	20200	21300	22300	23200	24100	25000
3000	17700	19000	20100	21200	22200	23100	24000	24900
3500	17700	18900	20000	21100	22100	23100	24000	24900
4000	17700	18900	20100	21100	22100	23100	24000	24900
4500	17800	19000	20100	21200	22200	23100	24100	24900
5000	17900	19100	20200	21300	22300	23200	24100	25000
5500	18000	19200	20300	21400	22400	23300	24300	25100
6000	18200	19400	20500	21500	22500	23500	24400	25200
6500	18300	19500	20600	21700	22700	23600	24500	25400
7000	18500	19700	20800	21900	22800	23800	24700	25500
7500	18800	19900	21000	22000	23000	23900	24800	25700
8000	19000	20100	21200	22200	23200	24100	25000	25900
8500	19200	20400	21400	22400	23400	24300	25200	26000
9000	19500	20600	21600	22600	23600	24500	25400	26200
9500	19700	20800	21900	22900	23800	24700	25600	26400
10000	20000	21100	22100	23100	24000	24900	25800	26600
10500	20300	21300	22300	23300	24200	25100	26000	26800
11000	20500	21600	22600	23600	24500	25300	26200	27000
11500	20700	21900	22900	23800	24700	25600	26400	27300
12000	20900	22200	23100	24100	24900	25800	26700	27500
12500	21200	22300	23300	24300	25200	26100	26900	27700
13000	21500	22500	23600	24600	25500	26300	27200	28000
13500	21800	22700	23900	24800	25700	26600	27400	28200
14000	22100	23000	24100	24900	26100	26900	27700	28500
14500	22400	23300	24200	25100	26300	27100	28000	28800
15000	22700	23600	24500	25400	26300	27200	28300	29000
15500	23100	24000	24800	25700	26500	27500	28400	29100
16000	23400	24300	25100	26000	26800	27700	28500	29300
16500	23800	24600	25500	26300	27100	27900	28600	29500

**Minimum Planning Range to Clear a Crest...**

Range to Crest of (m):	Angle of Site to Crest (mils):							
	10	20	30	40	50	60	80	100
<b>17000</b>	18500	19200	19800	20300	20800	21300	22300	23200
<b>17500</b>	19400	19800	20200	20700	21200	21700	22700	23600
<b>18000</b>	19600	20100	20700	21200	21700	22100	23100	24000
<b>18500</b>	20100	20600	21100	21600	22100	22600	23500	24300
<b>19000</b>	20500	21100	21600	22100	22500	23000	23900	24700
<b>19500</b>	21000	21500	22000	22500	23000	23400	24300	25100
<b>20000</b>	21400	22000	22500	22900	23400	23800	24700	25500
<b>20500</b>	22000	22500	22900	23400	23800	24300	25100	25900
<b>21000</b>	22400	22900	23400	23800	24300	24700	25500	26300
<b>21500</b>	23000	23400	23900	24300	24700	25100	25900	26700
<b>22000</b>	23400	23800	24300	24700	25200	25600	26400	27100
<b>22500</b>	23900	24400	24800	25200	25600	26000	26800	27600
<b>23000</b>	24300	24700	25300	25700	26100	26400	27200	28000
<b>23500</b>	24900	25300	25700	26100	26500	26900	27700	28400
<b>24000</b>	25400	25800	26200	26600	27000	27300	28100	28800
<b>24500</b>	25800	26300	26700	27100	27400	27800	28500	29200
<b>25000</b>	26400	26800	27200	27500	27900	28300	29000	29700
<b>25500</b>	26800	27300	27600	28000	28400	28700	29400	30100
<b>26000</b>	27300	27600	28100	28500	28800	29200	29900	30600
<b>26500</b>	27700	28200	28600	28900	29300	29600	30300	31000
<b>27000</b>	28300	28600	29100	29400	29800	30100	30800	31500
<b>27500</b>	28700	29200	29500	29900	30200	30600	31300	31900
<b>28000</b>	29300	29700	30000	30400	30700	31100	31700	0
<b>28500</b>	29700	30200	30500	30900	31200	31500	0	0
<b>29000</b>	30300	30700	31000	31400	31700	32000	0	0
<b>29500</b>	30700	31200	31500	31800	0	0	0	0
<b>30000</b>	31300	31600	32000	0	0	0	0	0
<b>30500</b>	31700	0	0	0	0	0	0	0
<b>31000</b>	0	0	0	0	0	0	0	0
<b>31500</b>	0	0	0	0	0	0	0	0



**FM 6-60**

**Minimum Planning Range to Clear a Crest...**

Range to Crest of (m):	Angle of Site to Crest (mils):							
	120	140	160	180	200	220	240	260
<b>17000</b>	24100	25000	25800	26600	27400	28100	28900	29700
<b>17500</b>	24500	25300	26100	26900	27700	28400	29200	29900
<b>18000</b>	24800	25700	26500	27200	28000	28800	29500	30200
<b>18500</b>	25200	26000	26800	27600	28300	29100	29800	30500
<b>19000</b>	25600	26400	27200	27900	28700	29400	30100	30800
<b>19500</b>	25900	26700	27500	28300	29000	29700	30400	31100
<b>20000</b>	26300	27100	27900	28600	29300	30100	30800	31500
<b>20500</b>	26700	27500	28200	29000	29700	30400	31100	31800
<b>21000</b>	27100	27900	28600	29300	30100	30800	31500	0
<b>21500</b>	27500	28300	29000	29700	30400	31100	31800	0
<b>22000</b>	27900	28600	29400	30100	30800	31500	0	0
<b>22500</b>	28300	29000	29800	30500	31200	31800	0	0
<b>23000</b>	28700	29400	30100	30900	31500	0	0	0
<b>23500</b>	29100	29800	30500	31200	31900	0	0	0
<b>24000</b>	29500	30200	31000	31600	0	0	0	0
<b>24500</b>	30000	30700	31400	32000	0	0	0	0
<b>25000</b>	30400	31100	31800	0	0	0	0	0
<b>25500</b>	30800	31500	0	0	0	0	0	0
<b>26000</b>	31300	31900	0	0	0	0	0	0
<b>26500</b>	31700	0	0	0	0	0	0	0
<b>27000</b>	0	0	0	0	0	0	0	0
<b>27500</b>	0	0	0	0	0	0	0	0
<b>28000</b>	0	0	0	0	0	0	0	0
<b>28500</b>	0	0	0	0	0	0	0	0
<b>29000</b>	0	0	0	MAX RANGE FAILS TO CLEAR CREST (32 km)			0	0
<b>29500</b>	0	0	0				0	0
<b>30000</b>	0	0	0	0	0	0	0	0
<b>30500</b>	0	0	0	0	0	0	0	0
<b>31000</b>	0	0	0	0	0	0	0	0
<b>31500</b>	0	0	0	0	0	0	0	0

**Minimum Planning Range to Clear a Crest...**

Range to Crest of (m):	Angle of Site to Crest (mils):							
	10	20	30	40	50	60	80	100
2000	0	0	0	12200	13400	15200	17000	18600
2500	0	0	0	0	12600	14100	16400	18100
3000	0	NO FIRING CONSTRAINT (10 km MIN RANGE)		0	12300	13800	16100	17900
3500	0			0	12200	13700	16000	17800
4000	0			0	12200	13700	16000	17800
4500	0			0	12300	13800	16100	17800
5000	0	0	0	0	12500	14000	16200	17900
5500	0	0	0	0	13100	14200	16400	18100
6000	0	0	0	10400	13400	14500	16600	18300
6500	0	0	0	12200	13700	15000	16800	18500
7000	0	0	0	12600	14000	15300	17100	18700
7500	0	0	0	12700	14400	15600	17300	19000
8000	0	0	11100	13200	14700	15900	17600	19200
8500	10900	11800	12700	14000	15100	16200	17900	19500
9000	11100	12100	13000	14400	15500	16500	18100	19800
9500	11800	12600	13400	14700	15900	16700	18400	20000
10000	12000	12800	14100	15300	16200	17000	18800	20300
10500	12600	13500	14600	15600	16500	17400	19100	20600
11000	12900	14000	15100	16100	16900	17700	19300	20900
11500	13500	14500	15600	16500	17300	18100	19600	21200
12000	14000	15100	16000	16900	17700	18500	19900	21400
12500	14700	15500	16400	17300	18100	18800	20300	21700
13000	15500	16000	16900	17700	18500	19200	20600	21900
13500	15700	16500	17300	18100	18900	19600	21000	22300
14000	16100	16900	17700	18500	19300	20000	21300	22600
14500	16600	17400	18200	18900	19700	20400	21700	22900
15000	17100	17900	18600	19400	20100	20800	22100	23300
15500	17500	18300	19100	19800	20500	21200	22400	23600
16000	18000	18800	19500	20200	20900	21600	22800	24000
16500	18600	19200	20000	20600	21300	22000	23200	24400

**FM 6-60**

**Minimum Planning Range to Clear a Crest...**

Range to Crest of (m):	Angle of Site to Crest (mils):							
	120	140	160	180	200	220	240	260
	<b>ALT: 3048 m ASL</b>							
<b>2000</b>	20100	21500	22700	24000	25100	26200	27300	28300
<b>2500</b>	19600	21000	22300	23600	24800	25900	27000	28000
<b>3000</b>	19400	20800	22200	23400	24600	25700	26800	27900
<b>3500</b>	19300	20700	22100	23300	24500	25700	26800	27900
<b>4000</b>	19300	20700	22100	23400	24500	25700	26800	27900
<b>4500</b>	19400	20800	22200	23400	24600	25800	26900	27900
<b>5000</b>	19500	20900	22300	23500	24700	25800	27000	28000
<b>5500</b>	19600	21100	22400	23600	24800	26000	27100	28100
<b>6000</b>	19800	21200	22500	23800	25000	26100	27200	28300
<b>6500</b>	20000	21400	22700	23900	25100	26300	27300	28400
<b>7000</b>	20200	21600	22900	24100	25300	26400	27500	28600
<b>7500</b>	20400	21800	23100	24300	25500	26600	27700	28700
<b>8000</b>	20700	22000	23300	24500	25700	26800	27900	28900
<b>8500</b>	20900	22300	23500	24700	25900	27000	28100	29100
<b>9000</b>	21200	22500	23800	24900	26100	27200	28300	29300
<b>9500</b>	21400	22700	24000	25200	26300	27400	28500	29500
<b>10000</b>	21700	23000	24200	25400	26500	27600	28700	29700
<b>10500</b>	22000	23300	24500	25700	26800	27900	28900	29900
<b>11000</b>	22300	23600	24700	25900	27000	28100	29100	30200
<b>11500</b>	22500	23800	25000	26200	27300	28300	29400	30400
<b>12000</b>	22700	24200	25300	26500	27500	28600	29600	30700
<b>12500</b>	22900	24400	25600	26700	27800	28900	29900	30900
<b>13000</b>	23200	24600	25700	27000	28100	29100	30100	31200
<b>13500</b>	23500	24800	25800	27300	28300	29400	30400	31500
<b>14000</b>	23800	25000	26100	27600	28600	29700	30700	31800
<b>14500</b>	24100	25300	26500	27900	29000	29900	31000	32000
<b>15000</b>	24400	25800	26800	28200	29200	30200	31300	0
<b>15500</b>	24800	26200	27100	28400	29400	30600	31600	0
<b>16000</b>	25200	26400	27300	28500	29800	30900	31900	0
<b>16500</b>	25700	26700	27600	28600	30100	31000	0	0

**Minimum Planning Range to Clear a Crest...**

Range to Crest of (m):	Angle of Site to Crest (mils):							
	10	20	30	40	50	60	80	100
<b>17000</b>	19000	19700	20400	21100	21700	22400	23600	24700
<b>17500</b>	19600	20200	20900	21500	22200	22800	24000	25100
<b>18000</b>	19900	20600	21300	22000	22600	23200	24400	25700
<b>18500</b>	20600	21100	21800	22400	23000	23600	24700	26100
<b>19000</b>	20900	21600	22200	22800	23400	24000	25200	26400
<b>19500</b>	21400	22100	22700	23300	23900	24400	25700	26700
<b>20000</b>	21900	22500	23100	23700	24300	24900	26100	27000
<b>20500</b>	22500	23000	23600	24200	24700	25400	26500	27400
<b>21000</b>	22800	23500	24100	24600	25200	25900	26800	27800
<b>21500</b>	23400	24000	24500	25100	25700	26300	27200	28200
<b>22000</b>	23800	24400	25000	25600	26200	26600	27600	28600
<b>22500</b>	24400	24900	25500	26100	26600	27000	28000	29000
<b>23000</b>	24800	25400	26000	26500	27000	27500	28500	29400
<b>23500</b>	25400	25900	26400	26900	27400	27900	28900	29800
<b>24000</b>	25800	26400	26900	27400	27900	28400	29300	30300
<b>24500</b>	26400	26800	27300	27800	28300	28800	29800	30700
<b>25000</b>	26700	27300	27800	28300	28800	29200	30200	31100
<b>25500</b>	27400	27800	28300	28800	29200	29700	30600	31600
<b>26000</b>	27700	28300	28700	29200	29700	30200	31100	32000
<b>26500</b>	28400	28800	29200	29700	30200	30600	31600	0
<b>27000</b>	28700	29200	29700	30200	30600	31100	32000	0
<b>27500</b>	29300	29700	30200	30700	31100	31600	0	0
<b>28000</b>	29700	30200	30700	31100	31600	0	0	0
<b>28500</b>	30300	30700	31200	31600	0	0	0	0
<b>29000</b>	30700	31200	31700	0	0	0	0	0
<b>29500</b>	31300	31700	0	0	0	0	0	0
<b>30000</b>	31700	0	0	0	0	0	0	0
<b>30500</b>	0	0	0	0	0	0	0	0
<b>31000</b>	0	0	0	0	0	0	0	0
<b>31500</b>	0	0	0	0	0	0	0	0

**ALT: 3048 m ASL**

**FM 6-60**

**Minimum Planning Range to Clear a Crest...**

Range to Crest of (m):	Angle of Site to Crest (mils):							
	120	140	160	180	200	220	240	260
	<b>ALT: 3048 m ASL</b>							
<b>17000</b>	26100	26900	27900	28900	30200	31200	0	0
<b>17500</b>	26400	27200	28200	29200	30500	31600	0	0
<b>18000</b>	26600	27600	28600	29500	30800	31900	0	0
<b>18500</b>	26900	27900	28900	29900	31000	0	0	0
<b>19000</b>	27300	28300	29300	30200	31200	0	0	0
<b>19500</b>	27600	28600	29600	30600	31600	0	0	0
<b>20000</b>	28000	29000	30000	30900	31800	0	0	0
<b>20500</b>	28400	29400	30300	31300	0	0	0	0
<b>21000</b>	28800	29800	30700	31600	0	0	0	0
<b>21500</b>	29200	30100	31100	32000	0	0	0	0
<b>22000</b>	29600	30500	31500	0	0	0	0	0
<b>22500</b>	30000	30900	31800	0	0	0	0	0
<b>23000</b>	30400	31300	0	0	0	0	0	0
<b>23500</b>	30800	31700	0	0	0	0	0	0
<b>24000</b>	31200	0	0	0	0	0	0	0
<b>24500</b>	31600	0	0	0	0	0	0	0
<b>25000</b>	0	0	0	0	0	0	0	0
<b>25500</b>	0	0	0	0	0	0	0	0
<b>26000</b>	0	0	0	0	0	0	0	0
<b>26500</b>	0	0	0	0	0	0	0	0
<b>27000</b>	0	0	0	0	0	0	0	0
<b>27500</b>	0	0	0	0	0	0	0	0
<b>28000</b>	0	0	0	0	0	0	0	0
<b>28500</b>	0	0	0	0	0	0	0	0
<b>29000</b>	0	0	0	<b>MAX RANGE FAILS TO CLEAR CREST (32 km)</b>			0	0
<b>29500</b>	0	0	0				0	0
<b>30000</b>	0	0	0	0	0	0	0	0
<b>30500</b>	0	0	0	0	0	0	0	0
<b>31000</b>	0	0	0	0	0	0	0	0
<b>31500</b>	0	0	0	0	0	0	0	0

## APPENDIX I

## LAUNCHER SECTION EVALUATION AND TRAINING

**Scope**

This appendix is an evaluation and training guide for the launcher sections of an MLRS firing battery. It is generic in scope and can be modified by the commander to meet local requirements and incorporate elements of the unit METL. It may be administered as follows:

- Formally or informally.
- With minimal administrative support.
- In the local training area.
- In a non-firing, tactical environment.

**Purpose**

The evaluation is a performance test of the skills that are essential to successful accomplishment of the mission of the launcher section. Although many of the tasks are evaluated on the basis of individual performance, the evaluation in fact measures the ability of the section to function as a team. The evaluation can be used as follows:

- To evaluate the current state of proficiency of the section.
- As a competitive evaluation to determine relative competence.
- As a basis for a training program in preparation for a formal battery or battalion training evaluation.
- As a supplement to performance oriented training.

The tasks should be used as training vehicles. As much time as possible should be devoted to controlled practice of a task. The sections should practice each task to acquire the degree of proficiency required by the standards set forth in the evaluation.

**Conduct of the Evaluation**

This evaluation examines the ability of the section chief to organize and train his personnel into a cohesive, effective fighting unit. It consists of five phases.

**Phase I** is an orientation and organization period beginning with a statement of the purpose, scope, and description of the evaluation. During Phase I, a written test will be administered. This phase should be conducted in a classroom at least a day prior to Phases II-V.

**Phase II** involves preparation in an assembly area for movement to an OPAREA and occupation of a hide area (HA).

**Phase III** covers the occupation of a hide area (HA) and selection of a firing point (FP) to include update, operational data and masking data.

**Phase IV** evaluates the conduct of various types of fire missions, and reload operations.

**Phase V** evaluates emergency procedures for a hangfire and an emergency destruction (ED).

**Phase VI** is an after action review (AAR) of the performances of each individual section.

**Note:** Phases II through V of the evaluation are built around a tactical scenario that can be changed to fit the unit METL, the training resources, and the time available.

**Evaluation Format**

The **task** is a general statement of the requirement of the particular evaluation.

The **conditions** outline the specific environment or situation in which the evaluation will be administered. They state what assistance or reference materials, if any, are authorized and what equipment or personnel are required for proper evaluation.

**Evaluation checklists** present the requirements for successful completion of that particular task. Specific technical procedures required in the task will be evaluated by the examiner on the basis of the established procedures in the appropriate reference. When necessary, units should modify task steps to more evenly weigh each step.

**Time scales** used during this section evaluation are not intended for use as fire mission time standards or expected

## FM 6-60

response times. These are found in ARTEPs 6-525-MTP and 6-398-30-MTP.

The enclosed scales assist unit commanders to further determine relative competence. If needed, the time scales should be adjusted to account for unit proficiency, software, and hardware changes. In order for a section to receive any time points all steps of that task must be scored GO.

### Scoring

The performance evaluation will be administered within a time framework on a GO or NO-GO basis; the section either passes or fails. The examiner will base his judgement on the criteria stated in the evaluation checklist and on the most current reference material.

In each block there is a GO value. When the task is completed, add the points and record the points in Table I-3, page I-4. If a section scores a NO-GO the score for that step is 0. Each task has a maximum amount of NO-GOs allowed to still receive a GO for that task. If a section exceeds that amount of NO-GOs the entire task is scored NO-GO and 0 points awarded.

### Preparation

All necessary preparations, as indicated in the conditions for each task, will be made before the task begins. The

examiner will ensure that the examinee understands the task to be performed.

### Qualification

If the evaluation is administered solely for the purpose of determining the state of training of individual sections within a unit, no formal score is required. The commander can readily determine the strengths and weaknesses of his section simply by subjectively analyzing the GO and NO-GO ratings received for each task performed.

The evaluation may be used to determine relative section proficiency within a unit or if a section meets a standard of excellence by determining a formal score. To determine the score for individual sections, add the numerical score attained in each of the four scored phases. See table I-1 for the qualification scheme.

**Table I-1. Qualification Scheme**

<b>Distinguished</b>	<b>951 - 1000</b>
<b>Outstanding</b>	<b>900 - 950</b>
<b>Excellent</b>	<b>800 - 899</b>
<b>Satisfactory</b>	<b>700 - 799</b>
<b>Not Qualified</b>	<b>0 - 699</b>

TABLE I-2. Organization and Scoring

PHASE	TASK	POINTS-TASK	POINTS-PHASE
I	ORIENTATION AND ORGANIZATION Task 1: Written test	250 Pts. (Max)	250 Pts. (Max)
II	PREPARATION FOR OPERATIONS Task 2: Pre-combat checks Task 3: Perform Launcher Startup Task 4: Conduct launcher calibration	35 Pts. (Max) 90 Pts. (Max) 40 Pts. (Max)	165 Pts. (Max)
III	OCCUPATION Task 5: Occupy an OPAREA Task 6: Input Mask Data	35 Pts. (Max) 50 Pts. (Max)	85 Pts. (Max)
IV	FIRING OPERATIONS Task 7: Enter / Review MET Data Task 8: Execute Fire Missions A: Execute A Manual Fire Mission (FWR) B: Execute A Digital Mission (AMC) C: Execute A Digital Fire Mission (TOT) Task 9: Perform A Reload Operation	15 Pts. (Max) 100 Pts. (Max) 100 Pts. (Max) 75 Pts. (Max) 100 Pts. (Max)	390 Pts. (Max)
V	EMERGENCY PROCEDURES Task 10: Perform Hangfire Procedures Task 11: Perform Emergency Destruction	35 Pts. (Max) 75 Pts. (Max)	110 Pts. (Max)
VI	AFTER ACTION REVIEW	N/A	N/A
		<b>TOTAL</b>	1000 Pts. (Max)
<p><b>Note:</b> This scoring breakdown is a suggested means of evaluating competing sections on a graded basis. The unit may change this scheme to fit its particular situation or training needs and priorities.</p>			



TABLE I-3. Recommended Grading Sheet

<b>LAUNCHER SECTION EVALUATION</b>	
DATE _____	SECTION _____
SECTION CHIEF _____	
GUNNER _____	DRIVER _____
<p><b>Phase 1 - Orientation and Organization</b></p> <p><b>TASK 1 - Written Test</b></p> <p>1. Grade the written tests. Record the percentages.</p> <p style="margin-left: 40px;">Chief _____ %</p> <p style="margin-left: 40px;">Gunner _____ %</p> <p style="margin-left: 40px;">Driver _____ %</p> <p>2. Average the section's score</p> <p style="margin-left: 40px;"><u>CHIEF + GUNNER + DRIVER</u></p> <p style="margin-left: 40px;">NUMBER OF SECTION MEMBERS</p> <p>3. Multiply the average by 2.5. This is the total points for Phase I.</p> <p style="margin-left: 40px;">Total Phase I _____</p> <hr/> <p><b>Phase II - Preparation for Operations</b></p> <p><b>TASK 2-Pre-Combat Checks</b></p> <p style="margin-left: 40px;">_____ Points</p> <p><b>TASK 3 - Perform Launcher Start Up</b></p> <p style="margin-left: 40px;">_____ Points</p> <p><b>TASK 4 -Launcher Calibration</b></p> <p style="margin-left: 40px;">_____ Points</p> <p style="margin-left: 40px;">Total Phase II _____</p> <hr/> <p><b>Phase III - Occupation</b></p> <p><b>TASK 5 - Occupy An OPAREA</b></p> <p style="margin-left: 40px;">_____ Points</p>	<p><b>TASK 6 - Input Masking Data</b></p> <p style="margin-left: 40px;">_____ Points</p> <p style="margin-left: 40px;">Total Phase III _____</p> <hr/> <p><b>Phase IV - Firing Operations</b></p> <p><b>TASK 7 - Enter MET Data</b></p> <p style="margin-left: 40px;">_____ Points</p> <p><b>TASK 8A - Execute A Manual Fire Mission (FWR)</b></p> <p style="margin-left: 40px;">_____ Points</p> <p><b>TASK 8B - Execute A Digital Fire Mission (AMC)</b></p> <p style="margin-left: 40px;">_____ Points</p> <p><b>TASK 8C - Execute A Digital Fire Mission (TOT)</b></p> <p style="margin-left: 40px;">_____ Points</p> <p><b>TASK 9 - Perform A Reload Operation</b></p> <p style="margin-left: 40px;">_____ Points</p> <p style="margin-left: 40px;">Total Phase IV _____</p> <hr/> <p><b>Phase V - Emergency Procedures</b></p> <p><b>TASK 10 - Perform Hangfire Procedures</b></p> <p style="margin-left: 40px;">_____ Points</p> <p><b>TASK 11 - Perform Emergency Destruction</b></p> <p style="margin-left: 40px;">_____ Points</p> <p style="margin-left: 40px;">Total Phase V _____</p> <hr/> <p><b>Phase V - After Action Review</b></p> <p style="margin-left: 40px;"><b>Grand Total</b> _____</p>

---

**Phase I**  
**ORIENTATION AND ORGANIZATION**

---

During this phase, preferably conducted on a day before administration of the remaining phases, the following are done:

- All personnel are briefed on the conduct and purpose of the training.
- The scoring system is explained.
- The organization of the training area and general administrative and safety procedures are explained.
- All questions are answered.
- The written test is administered to all section personnel.
- The examiner is provided a copy of the unit SOP to use during evaluation.

### Task 1- Written Test

The written test is based on FM 6-60, launcher technical manuals, and tasks in the Soldiers Manual (SM). The following test can be used as is or modified to meet a unit's METL. The correct answer to each question is found at the end of this appendix.

#### Conditions:

- All section members will take the written test.
- One hour is allocated for the test.

#### Scoring:

There is only one correct answer to each question unless otherwise stated. The scores of the section members are averaged to determine the section score. See Table I-3, Recommended Grading Sheet, for the grading formula.

1. All march columns, regardless of size, have three parts. What are they?

- A. Head, body and trail
- B. Advance, head and body
- C. Advance, main body and rear
- D. Advance, main body and detached

2. During convoy operations, orders are received by what element of the march column?

- A. Body
- B. Trail
- C. Head
- D. Advance

3. What external resupply control option places maximum control at the battery level?

- A. Centralized
- B. Shared
- C. Decentralized
- D. Unconsolidated

4. What external class V resupply control option requires the platoon to move directly to the ASP or ATP?

- A. Centralized
- B. Decentralized
- C. Shared
- D. Unconsolidated

5. What are the four types of tactical marches?

- A. Open column, close column, terrain march and infiltration
- B. Open column, dispatch route, terrain march and infiltration
- C. Open column, supervised route, terrain march and infiltration
- D. Close column bounding overwatch, terrain march and infiltration

6. When unloading a Guided/Missile Launch Assembly (GMLA), the prompt "WEAPON PURGE FAILURE LPC 1" appears, what action do you take?

- A. Notify next higher maintenance.
- B. Special handling procedures IAW Unit SOP.
- C. Perform emergency destruction on that GMLA.
- D. No action required is the prompt you should receive.

7. When the resupply truck and trailer arrive at the firing platoon operational area (OPAREA), who normally controls and monitors the ammunition resupply operations?

- A. Launcher section chief
- B. Ammo section chief
- C. Firing platoon sergeant
- D. Firing platoon leader

## FM 6-60

8. What is a key to MLRS platoon survivability?
- A. Establishment of listening posts (LPs).
  - B. Establishment of observation posts (OPs).
  - C. Use of land mines.
  - D. Avoidance of detection.
9. A rendezvous grid is used for what purpose?
- A. Consolidation and reorganization
  - B. Direct support maintenance linkup
  - C. Ammunition resupply linkup
  - D. All of the above
10. Hot refilling is one of the options for refueling. How is hot refueling accomplished?
- A. Vehicles are refueled at the ALOC.
  - B. The fuel truck is taken to the vehicle position.
  - C. Vehicles are refueled during movement.
  - D. Vehicles are refueled with five gallon cans.
11. What are the keys to a successful RSOP?
- A. Hasty recon, fire support
  - B. C3 logistical support
  - C. Discipline, teamwork and rehearsal
  - D. March techniques, terrain and speed
12. A platoon OPAREA should have a minimum of how many firing points?
- A. 3
  - B. 6
  - C. 9
  - D. 12
13. What is the minimum distance, in meters, allowed between firing points?
- A. 200
  - B. 300
  - C. 400
  - D. 500
14. During a fire mission, what is the approximate distance, in meters, behind the LLM that is considered a noise hazard danger area?
- A. 650
  - B. 700
  - C. 1200
  - D. 1500
15. During a hangfire, what checks must the section chief perform after the fire mission has been completed?
- A. Safe/Arm switch set to safe, vent fan switch set to medium
  - B. Vent Fan Control Override switch set to off
  - C. Ventilation Damper set to the firing position, all doors and windows closed
  - D. All of the above
16. The crew has unloaded a launch pod container (LPC) containing a hangfire. The Section Chief will ensure that they accomplished which of the following?
- A. Inspected the pod for cracks and gouges.
  - B. The shorting plug(s) is reconnected.
  - C. The pod is facing a safe field of fire.
  - D. All of the above.
17. "CHECK FIRE" can be received by FM data, voice transmission, or in person and can be initiated by:
- A. Section Chief
  - B. Gunner
  - C. OIC
  - D. Anyone
18. When reloading with M28A1 pods only, the W19 cable is connected to the pod and the W20 cable remains connected to the storage connector.
- A. True
  - B. False
19. When entering start up data, which source will only be used for location data in an emergency?
- A. Previously recorded data
  - B. Position data from a SCP
  - C. Nonvolatile random access memory
  - D. Map spot location
20. Prior to pressing LCHR LAY in a fire mission, the section chief:
- A. Ensures the launcher is positioned on level ground (slope less than 5 degrees/89 mils).
  - B. Ensures the launcher is positioned on level ground (9 degrees/85 mils).
  - C. Ensures the launcher is positioned on level ground (5 mils/89 degrees).
  - D. None of the above.
21. Once on the firing point, the launcher must be positioned within + or - 10 mils of the primary heading.
- A. True
  - B. False
22. Misfires and hangfires are treated in the same manner.
- A. True
  - B. False

23. After a hangfire, how many minutes wait time is recommended prior to conducting rocket disposal action?

- A. 10
- B. 20
- C. 30
- D. No waiting is required.

24. Always keep a shorting plug connected to a loaded LPC until:

- A. A SNVT is performed.
- B. Connecting an umbilical cable.
- C. Connecting a tested umbilical cable.
- D. All of the above.

25. Launch pods will be rejected if:

- A. Broken wiring is found.
- B. A launch tube and covers are loose or other indications that the seal is broken.
- C. Lifting bar is bent or cracked.
- D. All of the above.

26. When firing, it is recommended that your heading be less than how many roils off the display heading?

- A. 0
- B. 50
- C. 100
- D. 270

27. When measuring masking data, what is the minimum distance in meters you should be from the vehicle when using the M2 compass?

- A. 10
- B. 20
- C. 30
- D. 40

28. What is the minimum amount of time in seconds that can be entered in the "time between rounds" entry?

- A. 7
- B. 5
- C. 3
- D. 1

29. During a hangfire, if the launcher should become uncomfortably hot, what action should you take after 10 minutes?

- A. Exit the cab.
- B. Open the doors to the cab.
- C. Don NBC mask and set the vent switch to normal
- D. Set the vent switch to normal.

30. What is the correct azimuth resolver readout limit?

- A. -2.0 through +2.0 mils
- B. -1.8 through +1.8 deg
- C. -1.8 through +2.0 mils
- D. -1.8 through +1.8 mils

31. What is the correct elevation resolver readout limit?

- A. -1.8 through +1.8 mils
- B. -1.8 through +1.8 deg
- C. -2.0 through +2.0 mils
- D. -1.8 through +2.0 mils

32. What is your action if either the elevation or azimuth resolver readout exceeds tolerance limits?

- A. Attempt to adjust the resolver.
- B. Notify the OIC the launcher is INOP.
- C. Notify DS maintenance.
- D. Both b and c

33. How far in meters must you lower the hoist hooks before repositioning the upper pulley assembly?

- A. 1/2
- B. 1/3
- C. 2/3
- D. 1/4

34. When loading an M39 missile GMLA, what is the angle of balance and nose position?

- A. 20 degrees nose down
- B. 10 degrees nose up
- C. 15 degrees nose down
- D. 12 degrees nose up

For questions 35 thru 38 use the following chart:

Large Square	Upper Small Square	Lower Small Square
A. Yellow	Brown	White
B. Blue	Brown	Light Green
C. Bronze	N/A	N/A
D. Yellow	Brown	N/A

35 thru 38: The correct color codes for a(n)

35. M68 trainer is \_\_\_\_\_.

36. M28 and M28A1 are \_\_\_\_\_.

## FM 6-60

37. M26 is \_\_\_\_\_.
38. M39 GMLA is \_\_\_\_\_.
39. When the LLM is laying, what are the actions of the chief?
- A. Secure the cab.
  - B. Close louvers.
  - C. Ensure LLM is moving in the correct direction.
  - D. None of the above.
40. During a fire mission, what should the cab pressure gauge read?
- A. +25 PSI
  - B. +0.25 inches of water
  - C. +25.0 inches of water
  - D. +0.25 PSI
41. What is the maximum distance you are allowed to drag an LP/C during reload?
- A. The width of the LPC
  - B. 1/3 the width of the LPC
  - C. 1/2 the width of the LPC
  - D. 1/2 the length of the LPC
42. If the CMD and ACTL data for AZ and QE are not displayed when the LLM is laid, what are your actions?
- A. Press the C/E key and continue the mission.
  - B. Manually abort the mission and notify the OIC.
  - C. Abort mission and attempt again.
  - D. Verify LLM is in the direction of the target and continue.
43. How often is the hoist assembly required to be load tested?
- A. Annually
  - B. Monthly
  - C. Quarterly
  - D. Semiannually
44. Errors that are a function of total distance are corrected through the use of updates at SCPs. Updates are recommended after how many kilometers of travel?
- A. 6-8
  - B. 8-12
  - C. 6-10
  - D. 8-10
45. The lead seal missing on the external fire extinguisher handle does not render the vehicle NMC.
- A. True
  - B. False
46. If the handbrake handle is defective, it renders the vehicle NMC.
- A. True
  - B. False
47. Which of the following inoperative warning lights renders the vehicle NMC?
- A. Engine oil pressure
  - B. Transmission oil pressure
  - C. Fire warning.
  - D. All of the above
48. When you push on the brake pedal, it touches the cab forward wall. Is the vehicle mission capable?
- A. Yes
  - B. No
49. When slaving off a M270, the master switches of both vehicles should be in the on position until the slave cables are hooked up.
- A. True
  - B. False
50. When conducting a power check with the engine stopped, the master switch on, and the launcher switch off, what voltage are you reading?
- A. The generator output
  - B. The front generator
  - C. The LLM battery power
  - D. The vehicle battery power

Phase II  
**PREPARATION FOR OPERATIONS**

**Task 2- Pre-Combat Checks**

**Condition:** The launcher crew is in the motor pool or tactical assembly area (TAA). The platoon is preparing to leave this position to occupy an initial OPAREA.

Number of GOs____ Total Points_____
Evaluator's Initials _____

Evaluation Checklist	GO	NO-GO
Did the section have all section equipment installed or stowed in accordance with all applicable manuals and load plans? GO = 5 Pts.		
Were all necessary items on hand for performing the before operation checks and services on the launcher? (Bill, operator's manuals with changes, lubrication orders, log books)? GO = 5 Pts.		
Were the DA Forms 2404 or 5988-E completed properly for daily inspection of the LLM and carrier? GO = 5 Pts.		
Did the section inspect each item listed in the Before column of the PMCS tables of the operators manuals for the LLM and carrier? GO = 5 Pts.		
Did the section correct all faults discovered that they were authorized to correct in accordance with the operator's manual? GO = 5 Pts.		
Did the section use DA Form 2404 (ULLS 3856-R) to list all faults that they were not able to correct and that were not already listed. GO = 5 Pts.		
Was the operator licensed and the vehicle dispatched IAW local regulations and SOP? GO = 5 Pts		

**NO-GOs allowed: 2**

**Task 3- Perform Launcher Start up Procedures**

**Conditions:** The launcher is in the tactical assembly area (TAA), the FCS has no valid operational data. The radio system is off without COMSEC. Required COMSEC is on hand.

Evaluation Checklist	GO	NO-GO
Correctly enters JED POD ID number. GO = 10 Pts.		
Correctly enters All System Data. GO = 10 Pts.		
Correctly enters Comms Data. GO = 10 Pts.		
Correctly enters PDS data. GO = 10 Pts.		
Loads ECCM codes into the radio system. GO = 15 Pts		
Updates the PDS when alignment and compensation of the SRP occurs. GO = 10 Pts		
Completes the task within 5 minutes. Time stops when data is entered and radio equipment is loaded. Points: See Time Scale		

**NO-GOs allowed: 1**

Time Scale

0:01 - 1:30 Minutes.....	25 Points
1:31 - 2:45 Minutes.....	20 Points
2:46 - 3:30 Minutes.....	15 Points
3:31 - 5:00 Minutes.....	10 Points
5:01 Minutes or more.....	05 Points

Number of GOs ____ Time _____
Time Points _____ Total Points _____
Evaluator's Initials _____

**Task 4- Conduct Launcher Calibration**

**Conditions:** The launcher section is preparing to move to an initial OPAREA and the FCS requires calibration.

Evaluation Checklist	GO	NO-GO
Enters data into the FCS without error. GO = 15 Pts		
Parks correctly at all SCPs. GO = 5 Pts		
Performs calibration IAW TM 9-1425-646-10-2. GO = 10 Pts		
Checks and records Calibration parameters. GO = 10 Pts		

**NO-GOs allowed: 1**

**Additional instructions:** If the launcher does not calibrate due to crew error a score of 0 will be given for this task.

Number of GOs ____ Total Points _____
Evaluator's Initials _____

Phase III  
**OCCUPATION**

During this phase the launcher will occupy a hide area (HA) and select a firing point (FP) as part of an MLRS firing platoon. The section will update the launcher, send a database update to the POC, and derive and enter immediate masking data in order to establish a firing capability.

**Note:** Prior to occupying the OPAREA the launcher chief will be briefed on the location of survey control points (SCPs), reload point (RL) and the location of the launcher's firing area.

**Task 5- Occupy an OPAREA**

**Conditions:** The section has been briefed on location of survey, ammunition, and general location of firing areas.

Evaluation Checklist	GO	NO-GO
Updates the launcher at the survey control point (SCP). GO = 5 Pts.		
Moves to firing area and selects firing points and hide areas (IAW FM 6-60 criteria in chapter 4). GO = 10 Pts.		
Inputs the correct data base information into the FCS location menu. GO = 10 Pts.		
Sends a data base update to the POC/BOC. GO = 10 Pts.		

**NO-GOs allowed: 1**

Number of GOs \_\_\_\_ Time \_\_\_\_\_

Time Points \_\_\_\_\_ Total Points \_\_\_\_\_

Evaluator's Initials \_\_\_\_\_

**Task 6- Input Masking Data**

**Conditions:** The section has occupied their firing area and must determine masking data for an immediate mask.

Evaluation Checklist	GO	NO-GO
Section correctly derives data using an M2 Compass ( $\pm$ 10 mils). GO = 15 Pts.		
Enters data into the FCS GO = 10 Pts.		
Sends data to POC/BOC GO = 5 Pts.		
Time to complete Task Time Scale for Pts.		

**NO-GOs allowed: 1**

Time Scale

0:01 - 2:00 Minutes.....20 Points  
 2:01 - 3:00 Minutes.....15 Points  
 3:01 - 4:00 Minutes.....10 Points  
 4:01 - 5:00 Minutes.....05 Points  
 5:01 Minutes or more.....00 Points

Number of GOs \_\_\_\_ Time \_\_\_\_\_

Time Points \_\_\_\_\_ Total Points \_\_\_\_\_

Evaluator's Initials \_\_\_\_\_



Phase IV  
**FIRING OPERATIONS**

During this phase, the section will be evaluated on their proficiency conducting firing operations to include reviewing MET data, fire missions, reload of ammunition, and hangfire procedures.

**Note:** For all fire missions the launcher will be in a hide area within 100 meters of the firing point. Movement time from the hide area to the firing point will be included in the overall mission time. Time starts when the launcher receives the fire mission and presses the ACK key. Time stops when the launcher fires the first round. If the mission is given manually, the time will start when the section chief has verified the firing data to the evaluator.

**Task 7- Enter MET Data**

**Conditions:** The launcher is in a hide location. The launcher chief is given a computer MET message containing new MET data.

Evaluation Checklist	GO	NO-GO
Section manually enters all MET data. GO = 10 Pts.		
Corrects errors if found during review. Reports to the BOC/POC that the MET was entered. GO = 5 Pts.		

**NO-GOs allowed: 0**

Number of GOs \_\_\_\_\_ Total Points \_\_\_\_\_

Evaluator's Initials \_\_\_\_\_

Evaluation Checklist	GO	NO-GO
Enters FM data and executes. GO = 10 Pts.		
Firing section parks properly on the firing point. Checks/ Uses the correct masking data. GO = 5 Pts.		
Moves the gear selector to neutral and sets the parking brake. GO = 5 Pts.		
Engages the suspension lockout. Ensures the launcher interconnect switch is on. Raises the throttle and checks that the voltmeter is in upper 50% green. GO = 10 Pts.		
Checks/Sets vent fan override on driver's instruments panel to control (off) position. GO = 5 Pts.		
Sets the vent fan to medium and places firing damper in the firing position. GO = 5 Pts.		
Closes doors and louvers. GO = 5 Pts.		
Press LCHR LAY key. GO = 5 Pts.		

**Task 8- Execute a Fire Mission**

**Conditions:** The launcher is in a hide location and has assumed a firing capability. Communications with the POC/BOC have been established and the launcher is waiting to receive MLRS Calls For Fire. The launcher is loaded with an M68 LP/C trainer in each bay. No faults selected.

**Task 8a - Execute a Manual Fire Mission (FWR)**

**Conditions:** The launcher is in a hide area (HA) and receives a voice fire mission. Method of control is fire when ready (FWR).

Section Chief watches the LLM move toward the commanded direction. Secures the hatch and closes the louver. GO = 5 Pts.		
Checks differential pressure gage for .25 or more. GO = 5 Pts.		
Arms and fires rockets when prompted. GO = 5 Pts.		
Closes cover on the SAFE switch and sends a voice mission fired report (MFR) to POC/BOC. GO = 5 Pts.		
Checks for a launch tube fire. Stows the LLM. Displaces from the firing point. GO = 5 Pts.		
Time taken to complete the timed portion of the task. Pts. = See Time Scale		

**NO-GOs allowed: 2**

Time Scale

0:01 - 3:30 Minutes.....	25 Points
3:31 - 3:45 Minutes.....	20 Points
3:46 - 4:00 Minutes.....	15 Points
4:01 - 4:15 Minutes.....	10 Points
4:16 - 4:30 Minutes.....	05 Points
4:31 Minutes or more.....	00 Points

Number of GOs _____ Time _____
Time Points _____ Total Points _____
Evaluator's Initials _____

**Task 8b - Execute a Digital Fire Mission (AMC)**

**Conditions:** The launcher receives a digital FM while at the hide area (HA) and must execute the FM. Method of control is at my command (AMC).

Evaluation Checklist	GO	NO-GO
Presses ALM ACK (Time Starts) upon receipt of FM. Parks properly on the firing point. Checks / Uses the correct masking data. GO = 5 Pts.		
Moves the gear selector to neutral and sets the parking brake. GO = 5 Pts.		
Engages the SLO. Ensures the launcher interconnect switch is on. Raises the throttle and checks that the voltmeter is in upper 50% green. GO = 10 Pts.		
Checks/Sets vent fan override on the driver's instruments panel to control (off) position. GO = 5 Pts.		
Sets the vent fan to medium and places the firing damper in the firing position. GO = 5 Pts.		
Closes doors and louvers GO = 5 Pts.		
Presses launcher lay key. GO = 5 Pts.		
Section Chief watches the LLM move toward the commanded direction. Secures the hatch and closes the louver. GO = 5 Pts.		
Checks differential pressure gage for .25 or more pressure. GO = 5 Pts.		
Ensures "Ready to Fire" Message is sent (Time stops). If not Received by BTRY/PLT, gunner sends another message. GO = 5 Pts.		

Receives "Call for Fire." Acknowledges and transmits WILCO. The Gunner arms and fires the rockets when prompted. GO = 10 Pts.		
Closes cover on the SAFE switch and ensures MFR is sent to POC/BOC. GO = 5 Pts.		
Checks for a launch tube fire. Stows the LLM. Displaces from the firing point. GO = 5 Pts.		
Time taken to complete the timed portion of the task. Pts. = See Time Scale		

**NO-GOs allowed: 2**

Time Scale

0:01 - 2:45 Minutes.....	25 Points
2:46 - 3:00 Minutes.....	20 Points
3:01 - 3:15 Minutes.....	15 Points
3:16 - 3:30 Minutes.....	10 Points
3:31 - 3:45 Minutes.....	05 Points
3:46 Minutes or more.....	00 Points

Number of GOs ____ Time _____
Time Points ____ Total Points ____
Evaluator's Initials _____

**Task 8c- Execute a Digital Fire Mission (TOT)**

**Conditions:** The launcher is in the hide area and receives a digital FM (TOT).

Evaluation Checklist	GO	NO-GO
Received TOT Fire Mission. ALM/ACK key pressed. Firing section parks properly on the firing point. Checks/ Uses the correct masking data. GO = 10 Pts.		

Moves the gear selector to neutral and sets the parking brake. GO = 5 Pts.		
Engages the SLO. Ensures the launcher interconnect switch is on. Raises the throttle and checks that the voltmeter is in upper 50% green. GO = 10 Pts.		
Checks/Sets the vent fan override on the driver's instrument panel to control (off) position. GO = 5 Pts.		
Sets the vent fan to medium and places the firing damper in the firing position. GO = 5 Pts.		
Closes doors and louvers. GO = 5 Pts.		
Press launcher lay key. GO = 5 Pts.		
Section Chief watches the LLM move toward the commanded direction. Secures the hatch and closes the louver. GO = 5 Pts.		
Checks differential pressure gauge for .25 or more. GO = 5 Pts.		
Arms and fires the rockets when prompted. GO = 10 Pts.		
Closes the cover on the SAFE switch and sends MFR to POC/BOC. GO = 5 Pts.		
Checks for a launch tube fire. Stows the launcher loader module (LLM). Displaces from the firing point. GO = 5 Pts.		

**NO-GOs allowed: 2**

**Additional Instructions:** If the crew does not complete the FM a NO-GO for the entire task is given and 0 points scored.

Number of GOs ____ Total Points ____
Evaluator's Initials _____

### Task 9- Perform a Reload Operation

**Conditions:** The launcher has just arrived at a reload point (RL) with two expended LPCs. Two full LPCs or GMLAs (simulated) are present and positioned for reload. A SCP has been established within 10 meters of the RL.

Evaluation Checklist	GO	NO-GO
Chief dismounts and moves to LPCs, inspects LPCs and records LOT/SN, positions launcher for reload operations. Time Starts when parked. GO = 5 Pts.		
Section prepares the launcher for reload operations by: <ul style="list-style-type: none"> <li>- Moving the gear selector to neutral</li> <li>- Setting the hand brake</li> <li>- Engaging SLO</li> <li>- Setting the throttle</li> <li>- Checking the interconnect switch.</li> <li>- Checking voltage</li> <li>- Enabling boom controller</li> </ul> GO = 10 Pts.		
Section unloads LPCs: <ul style="list-style-type: none"> <li>- Chief unlatches LPCs</li> <li>- Disconnects the umbilical cables from LPCs and connects to the launcher</li> <li>- Conducts SNVT test</li> <li>- Removes shoes</li> <li>- Ensures D-rings are up</li> <li>- Unloads expended LPCs.</li> <li>- Positions LLM for reload.</li> </ul> GO = 10 Pts.		

<b>Section loads LPCs:</b> <ul style="list-style-type: none"> <li>- Positions LLM boom over LPCs.</li> <li>- Cables down and moves the hook hoist to the lifting bar.</li> <li>- Cables up LPCs to boom carriage.</li> <li>- Inspects bottom of LPCs</li> <li>- Loads LPCs</li> <li>- Conducts SNVT Test</li> </ul> GO = 10 Pts.		
<ul style="list-style-type: none"> <li>- Connects the umbilical cables to each LPC.</li> <li>- Replaces and secures boom controller.</li> <li>- Latches LPC in position.</li> <li>- Stows LLM.</li> <li>- Enters POD ID</li> <li>- Time stops when travel lock hooks engage.</li> </ul> GO = 10 Pts.		
Moves to SCP and completes a PDS update. GO = 5 Pts.		

**NO-GOs allowed: 2**

**Additional instructions:** If either SNVT test is missed or out of sequence a NO-GO is given for the entire task and score 0 points.

Time Scale

0:01 - 6:00 Minutes.....	50 Points
6:01 - 7:30 Minutes.....	40 Points
7:31 - 9:00 Minutes.....	30 Points
9:01 - 10:30 Minutes.....	20 Points
10:31 - 12:00 Minutes.....	10 Points
12:01 Minutes or more.....	00 Points

Number of GOs ____ Time _____
Time Points ____ Total Points ____
Evaluator's Initials _____

Phase V  
**EMERGENCY PROCEDURES**

**Task 10-Perform Hangfire Procedures**

**Conditions:** The launcher has received a fire mission and the fire control panel indicates a hangfire condition.

**Note:** Unit SOP as directed by TM 9-1425-646-10-2 should be used to further clarify exact actions to be taken when a hangfire occurs.

Number of NO-GOs \_\_\_\_ Total Points \_\_\_\_  
Evaluators Initials \_\_\_\_\_

Evaluation Checklist	GO	NO-GO
<ul style="list-style-type: none"> <li>- Safes the FCS by placing the arm switch to safe.</li> <li>- Ensures MFR was sent.</li> </ul>		
Section stays inside the cab and performs a cab check. <ul style="list-style-type: none"> <li>- Checks the vent fan is set to medium</li> <li>- Checks the vent fan switch on the panel is placed on control.</li> <li>- The ventilation damper is in the firing position.</li> <li>- Ensures the louvers, blackout window, ballistic window covers are closed and the hatch and doors are closed.</li> </ul>		
(If simulating time, the evaluator has the crew explain.) After waiting 10 Minutes. <ul style="list-style-type: none"> <li>- wear NBC masks</li> <li>- Set the damper to normal</li> </ul>		
Waits 30 minutes (total). Call POC/BOC for further instructions. (Ordered to Stow and move). <ul style="list-style-type: none"> <li>- INIT to override.</li> <li>- Drives slowly to unloading site.</li> <li>- Opens only the driver's louver.</li> <li>- Unloads LP/C(s)</li> <li>- Shorting Plugs Installed on LP/C.</li> </ul>		

**NO-GOs allowed 0. GO=35 points.**

**Task 11- Perform Emergency Destruction**

**Conditions:** The launcher has received orders to destroy the launcher and/or ammunition.

Evaluation Checklist	GO	NO-GO
Verifies destruct order.		
Walks safe distance. Records time.		
Test burns (cut/discards first 6 inches) 3 feet. Records time. Computes the amount of time fuze needed, (Walk time / Burn time).		
Cuts/places C-4 in correct places. Prepares branch and main lines. 6 inch overhang Closed loop (main line)		
Evacuates non-essential personnel. Places blasting caps (C4 and time fuze- det. cord). Connects fuze igniters. Verifies ED order. Ignites time fuze, evacuates. Verifies equipment is destroyed IAW unit SOP.		

**NO-GOs allowed 0. GO = 75 points.**

Number of GOs \_\_\_\_ Total Points \_\_\_\_  
Evaluators Initials \_\_\_\_\_

---

## Phase VI AFTER ACTION REVIEW

---

### General

Before starting the AAR, the evaluator must ensure all participants are present and ready.

The evaluator provides the focus for the AAR by briefly restating the specific training and/or evaluation objectives. Next, he asks the section chief to summarize the section's activities.

Initially, the evaluator should only ask questions--why certain actions were taken, how personnel reacted to situations, and when actions were initiated. He must limit his input to sustaining the AAR, guiding the discussion back to the right track, or bringing out new points.

Techniques which will help the evaluator guide the discussion include:

- Ask leading and thought-provoking questions that focus on the training objectives. Ask crew members what METT-T factors influenced their actions.
- Have the section members describe what happened in their own words and from their own point of view. They should be free to discuss not only what took place, but also why it took place.
- Explore alternative courses of action that might have been more effective. (How could you have done it better?)
- Avoid detailed examination of events not directly related to major training objectives unless the section chief wants to go into greater detail.

### Present Formal Results

The evaluator should present the numerical results of the section evaluation. He should also recognize and highlight outstanding performances.

### Discuss Mistakes

Many times the discussion must focus on mistakes. This discussion should be frank, but without embarrassing

those involved. The positive must be emphasized so that lessons can be learned without destroying confidence or respect. Others can learn from a mistake and gain an appreciation for the difficulties involved in leading.

### Use Appropriate Training Aids

Training aids can significantly contribute to the AAR discussion if they have been carefully selected. They must not distract from the AAR.

For example, a detailed and done-to-scale terrain table showing the OPAREA where the evaluation was conducted would be inappropriate if the AAR site had a view of the actual terrain. Some keys to the successful use of training aids follow:

- Use the actual terrain whenever possible.
- When using terrain models and maps, orient the participants to the key terrain. Use correct symbols and graphics.
- Use charts to emphasize data that need to be discussed.

### Summary and Questions

Evaluators should answer any questions that the crewmen may have. Once all the key points have been discussed and linked to future training, the evaluator should leave the immediate area and allow the unit leader and soldiers the opportunity to discuss the events in private.

Evaluators should try not to unduly damage self-esteem or cohesion. To do so would be contrary to the AAR's goal of improving performance.

By the end of the AAR, soldiers must clearly understand what was good, bad, and average about their performances. The art of the after action review process is to get soldiers to accurately grade their own performances.

**Written Test Answer Key**

1	A	11	C	21	B	31	A	41	C
2	C	12	C	22	B	32	D	42	B
3	A	13	D	23	C	33	B	43	A
4	B	14	B	24	C	34	D	44	A
5	A	15	D	25	D	35	C	45	B
6	B	16	D	26	C	36	B	46	A
7	C	17	D	27	C	37	D	47	D
8	D	18	A	28	B	38	A	48	B
9	D	19	D	29	C	39	C	49	B
10	C	20	A	30	A	40	B	50	D

## APPENDIX J

## SAFETY

Safety is always a prime consideration of soldiers and trainers at all levels, especially when training exercises use live ammunition. Often, the implementation of safety procedures becomes counterproductive, preventing units from conducting realistic live-fire training. Units must be able to conduct realistic training using live or training ammunition while meeting all safety requirements. The procedures in this chapter are based on the principles of artillery safety in AR 385-63 and cover peacetime safety practices and procedures for MLRS firing. Units following these procedures can conduct safe, effective life-fire training exercises.

### Section I RESPONSIBILITIES AND PROCEDURES

#### Responsibilities

AR 385-63, Chapter 11, implements the chain-of-command safety concept. Under this concept, the firing battery chain of command is responsible for safety during firing in both training and combat. This chapter reinforces AR 385-63, however, if local range regulations are more restrictive than the material in this chapter, the local range regulations must be followed.

#### Range Control/ Installation Range Officer

The installation range officer provides to the officer in charge (OIC) a range safety card. This card states the location coordinates of the launcher firing area and the location coordinates of the target(s) to be engaged. The range officer also identifies any special instructions that must be followed in firing at that range (road guards, time constraints, Air Force overflights, and so on). He is responsible for constructing and verifying surface danger zones for MLRS firing areas. He prepares and maintains all waivers IAW AR 385-63. All waivers must be approved by a general officer at the installation command level.

#### Commanders of Field Artillery Units

Commanders establish and maintain a safety training and certification program for their unit personnel. The purpose of this program is to train and qualify individual members of the firing battery in the safety procedures for their specific areas of responsibility. When the responsible commander is satisfied that the individual members are qualified to perform the safety duties as required in the firing battery, he certifies them as

competent to perform those duties. The FA battalion commander is responsible for safety during all phases of a firing exercise under his control. He selects, trains, and certifies the personnel necessary to help him discharge this responsibility. These personnel include, but are not limited to, the firing battery commander, battery operations officer, firing platoon leader, fire direction computers, and launcher section chiefs. If any position is not filled by a command safety-certified person, another person who is certified and qualified to fill that position performs the safety checks.

#### Officer in Charge

The OIC is the battery commander or his command safety-certified direct representative. The OIC is responsible for all aspects of safety in the firing unit and on the assigned firing range. Before the firing exercise, the range control officer provides the OIC the required safety data and any firing limitations. The OIC verifies that the unit is in the proper firing position. He supervises the conversion of the safety data into a safety diagram and ensures that this diagram is verified by another command safety-certified person. The OIC is responsible for ascertaining locations of friendly personnel who may inadvertently become exposed to artillery fires through the installation range safety officer. He ensures dissemination of this information to platoon leaders, platoon sergeants, and chiefs of section, as appropriate, so they are aware of potential situations which might result in fratricide.

#### Firing Platoon Leader

The firing platoon leader is responsible for the safety practices of the firing element. He ensures that section chiefs report firing data to the POC/BOC. He ensures that the launcher danger area is clear.



## FM 6-60

### Platoon Sergeant

The platoon sergeant assists the platoon leader in his duties. He must be prepared to perform any of the platoon leader's duties in his absence.

### Section Chief

The launcher section chief is responsible for the operation of his crew from the reload point through rocket launch. He ensures that all procedures in the launcher are conducted in accordance with applicable technical manuals and that all reports and checks are verified in accordance with the procedures outlined in this chapter. He is ultimately responsible for ensuring munitions are neither armed nor fired until firing data is properly verified as safe. Specific duties of the section chief are contained in subsequent paragraphs.

### Procedures

The MLRS launcher FCS is designed to perform many repetitive self-tests during operations. Built into both the launcher hardware and software, these tests check and continually monitor the launcher throughout its operation. Additional manual checks should focus on crew-error, the area which has caused most launcher-related firing incidents. Checks which verify all data input into the FDS and launcher FCS eliminate most of the causes of firing incidents.

MLRS firing data (azimuth, quadrant elevation, and fuze setting) are computed by the FCS. The FCS conducts internal tests, all of which must be within system accuracy tolerances, before allowing the launcher to fire. To complete a firing sequence, the LLM must be oriented and maintain accuracy within  $\pm 3$  mils of the FCS ballistic solution (CMD vs actual data displayed on the FCP). If for any reason the launcher drive system (LDS) fails, (part wear, adverse mechanical failure, etc.) preventing the LLM from reaching or maintaining its computed ballistic firing window, the FCS will cancel the fire mission and not allow the crew to fire the rockets. Additionally, during the conduct of every fire mission, the FCS further verifies its LLM position by comparing its data against a mechanical reference provided by azimuth and angle position transducers. These transducers are fitted to the rotating band of the launcher turret and the launcher elevation actuator. A failure of agreement between the FCS and its mechanical resolvers will alert the crew through a warning message. Any indication of a system error (BIT light or prompt on the FCP) will cause

the crew to immediately abort the mission in progress and troubleshoot the fault before continuing.

Operator error is minimized through verification of launcher firing data. This verification must be made by a safety certified individual. The independence of this check is maintained in one of two ways:

- By ensuring data input is by two different methods for the firing and check launchers (i.e., manual entry vs data transmission) when conducting static firings. This includes meteorological data, update and target grid coordinates, altitudes and grid zones. It also consists of a comparison of the command firing data from a calibrated launcher FCS (firing launcher) and computed data from an independent launcher (non-firing).
- By ensuring data input is observed by two safety certified personnel (e.g., gunner and section chief for the FCS; fire direction computer and operations officer for the FDS). It also includes a check by both the gunner and section chief of the actual firing data to ensure it falls within the safety "T" when conducting live fire exercises using the safety computations in Section II.

Additionally, the PADS-established SCP must always be verified. A hard copy of the data is sent via a location status message to the BOC and POC, where it is validated and retained. The BOC and POC file this information for historical record. In the BOC and POC, the operations officer (BOC) and platoon leader (POC) verify that the met data and impact area target location were correctly entered by the FDS operator and transmitted digitally to the firing launcher(s), where the data are automatically entered into the FCS. This independent verification of start-up data by the launcher section chief and the platoon leader ensures that accurate position data are used during fire mission computation. The gunner ensures, and the section chief verifies, that start-up and update data are properly entered into the launcher FCS.

The tolerances within which the launcher can accurately position and fire during practice firings are identical to those used in a tactical situation. This enhances tactical realism during training and validates the system capability. Procedures for firing safety involve a properly calibrated launcher, verification that the FCS is functioning properly, and verified launcher firing position within a designated firing area. Strict adherence to the operator's manual

procedures and/or warning indicators and a hard copy of the launcher firing ballistic solution sent via a MFR to the BOC and POC for historical record are required.

Use of observers located near and properly oriented on the impact area to observe a warhead event (M28) or safe

impact (M28A1) for safety verification depends on local installation range SOP. If spotting of the warhead is required, visual observers or radar tracking (AN/TPQ-37) may be used. A sample MLRS firing safety checklist is provided at the end of this Appendix.

---

## Section II

### COMPUTATION OF SAFETY DATA (M28 and M28A1 Training Rockets)

---

**Units using these procedures must be thoroughly familiar with the applicable terms and basic safety computations for each of the training rockets (M28 and M28A1) contained in AR 385-63. These procedures incorporate the procedures for developing the surface danger zones (SDZs) contained in that regulation. They apply the SDZ requirements around an installation impact area rather than a specific target. They also apply the launcher danger areas to either individual firing points or a larger firing OPAREA. In the event of a conflict, AR 385-63 has precedence. The examples described herein are based on the M28A1 Training Rocket (reduced range).**

---

#### General

There are three methods to compute safety data for MLRS live-firing. The first of these is for point-to-point firings using the SDZ diagrams contained in AR 385-63 and the safety checklist at the end of this appendix. The other two methods allow the unit to develop a safety "T" for either a firing point or a firing OPAREA. Both of these latter methods apply all of the SDZ requirements established in AR 385-63.

The first method allows the unit to derive a safety "T" for a single firing point firing into a "target selection box." The second method requires a larger impact area, but allows the unit to derive a single safety "T" for an entire launcher OPAREA firing into a target selection box. Both of these latter methods allow the unit to conduct more realistic and tactically driven live-fire exercises, thus significantly enhancing training.

OPAREA safety works well when conducting live-fire exercises with the M28A1 Training Rocket (reduced range). Although these procedures can be used with the standard M28 Training Rocket, its much larger values for W, X, and Y (see *Definition of Terms*) necessitate exceptionally large installation impact areas (see Tables J-1 and J-2, page J-4). Inordinately small impact areas may preclude the use of these procedures with the M28A1 Training Rocket (reduced range) as well.

Safety computations for each of these methods are completed in four phases. *Phase I* is the application of the

SDZ requirements (for the specific munition) to the installation impact area. *Phase II* is the derivation of the firing limits in both azimuth (AZ) and quadrant elevation (QE). *Phase III* is the application of the SDZ requirements (for the specific munition) to the launcher firing point or OPAREA. *Phase IV* is the completion of the flight corridor.

#### Definition of Terms

<b>AoF</b>	Azimuth of Fire.
<b>H</b>	Height of the launcher above mean sea level.
<b>W</b>	A distance to either side of the target wide enough to include all debris (payload, warhead skin, and rocket motor) from normally functioning rounds.
<b>W<sub>max</sub></b>	The maximum possible value of W. For OPAREAs, this is the value of W at a range from the rear edge of the OPAREA to the target (maximum range).
<b>X</b>	A distance beyond the target adequate to contain rockets when the fuze fails to function.
<b>X<sub>max</sub></b>	The maximum possible value of X. For OPAREAs, this is the value of X at a range from the forward edge of the OPAREA to the target (minimum range).

**FM 6-60**

**Y** A distance short of the target sufficient to include all debris (payload, warhead skin, and rocket motor) from normally functioning rounds.

**Y<sub>max</sub>** The maximum possible value of Y. For OPAREAs, this is the value of Y at a range from the forward edge of the OPAREA to the target (minimum range).

**Table J-1. M28 Safety Values**

		RANGE TO TARGET (m)	W	X	Y
<b>M 2 8</b>		10,000 to 11,500	1,160	8,000 + H	2,200
		11,501 to 15,000	1,320	6,300 + H	2,200
		15,001 to 20,000	1,620	5,000 + H	2,200
		20,001 to 23,000	1,820	3,200 + H	2,200
		23,001 to 27,000	2,220	3,600 + H	2,200
		27,001 to Maximum	3,220	4,000 + H/2	2,200

**Table J-2. M28A1 Safety Values**

		RANGE TO TARGET	W	X	Y
<b>M 2 8 A 1</b>		8,000 to 9,000	560	2,450	1,930
		9,001 to 10,000	620	2,100	1,500
		10,001 to 11,000	685	1,800	1,180
		11,001 to 12,000	760	1,560	900
		12,001 to 13,000	850	1,475	600
		13,001 to 14,000	950	1,580	450
		14,001 to 15,000	1,050	1,760	350

**Note:** When firing the standard M28 training rocket. 320 meters has already been added to the value of W (to account for Area A), 1,300 meters has already been added to the value of X (to account for Area B), and Y will always equal 2,200 meters. W and X values for the M28A1 training rocket by definition include areas A and B respectively.

**Firing Point Method**

**Phase I**

Apply the SDZ requirements to the installation impact area:

**STEP 1.** Outline the usable portion of the installation impact area. Index the approximate geographic center of this area (target).

**STEP 2.** Index the firing point.

**STEP 3.** Draw a line segment connecting the two indices from steps 1 and 2.

**STEP 4.** Apply the values of  $W_{max}$ ,  $X_{max}$ , and  $Y_{max}$  to the edges of the installation impact area (toward the target). These values should be based on ranges from the firing point to the near edge (minimum range) and far edge (maximum range) of the installation impact area. This is the *SDZ Impact Area*.

**Phase II**

*Determine the Left and Right Azimuth Limits.*

**STEP 1.** Draw line segments from the firing point to the right and left edges of the SDZ Impact Area which will keep all rounds within the SDZ Impact Area (safety fan). You must also apply any azimuth restrictions imposed by the installation safety office for the firing area. (See Figure J-1, page J-5.)

*Derive the Minimum and Maximum Values for Quadrant Elevation (QE).*

**STEP 2.** Measure the minimum and maximum ranges to the near and far edges of the SDZ impact area (within the azimuth limits). You must also consider min and max range limits imposed by the range safety office. Using the current MET message, determine the associated firing azimuths and QEs with a launcher FCS by dry firing missions at the lower left and upper right corners. The lower left mission will determine the left azimuth limit and min QE. The upper right mission will determine the right limit and max QE. This completes the safety "T" for firing point method (see Figure J-2).

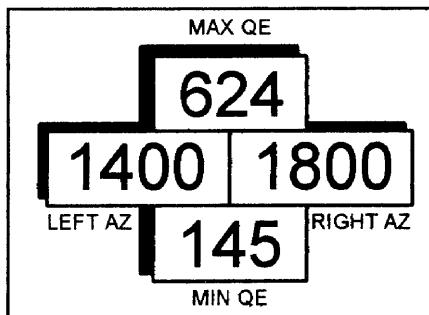

**Figure J-2. Safety T.**

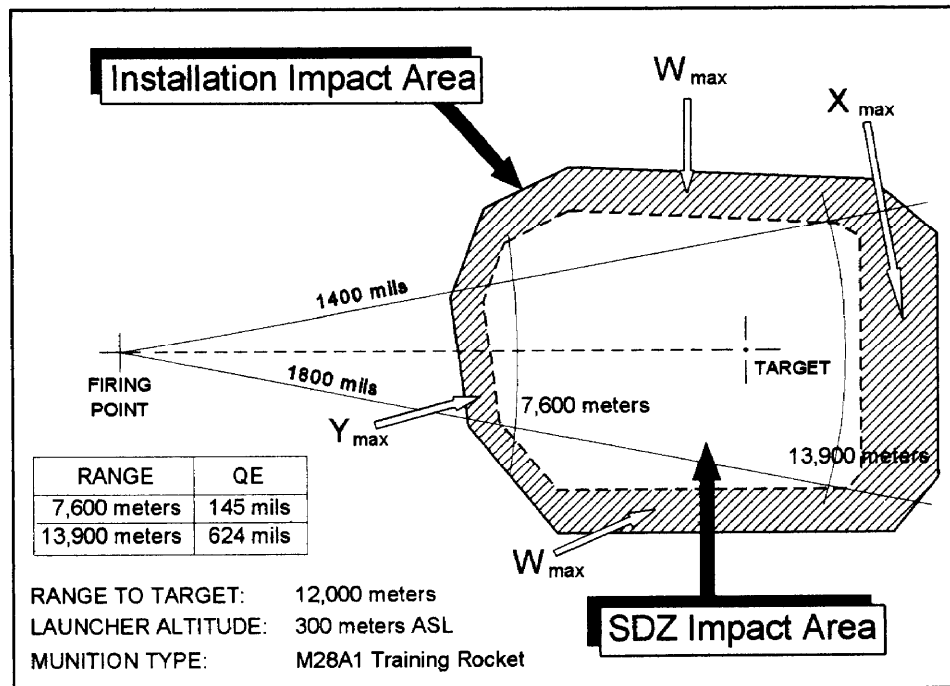

Figure J-1. Left and right azimuth limits.

**Phase III**

*Complete the Launcher Danger Areas.*

**STEP 1.** Area F (Launcher Danger Area) is the area immediately to the rear of the launcher which is directly exposed to blast and debris. It extends 350 meters to the left and right of the launcher firing point (perpendicular to the AoF) and 400 meters to the rear of the firing point (parallel to the AoF). Personnel are prohibited from occupying this area.

**STEP 2.** The Noise Hazard Area (NHA) extends behind Area F. It can only be occupied by mission essential personnel wearing double hearing protection. Draw a box that extends beyond Area F an additional 300 meters (500 meters for the M28 rocket) to the rear of the firing point (Figure J-3).

**Phase IV**

*Complete the Flight Corridor*

**STEP 1.** Construct line segments from the left and right forward edge of Area F to the left and right near edge of the Installation Impact Area respectively that are parallel to the left and right azimuth limits (see Figure J-4, page J-6).

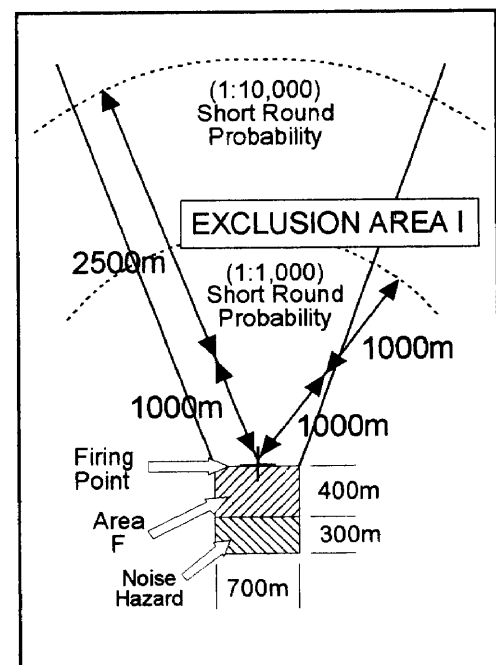

Figure J-3. Noise hazard area.

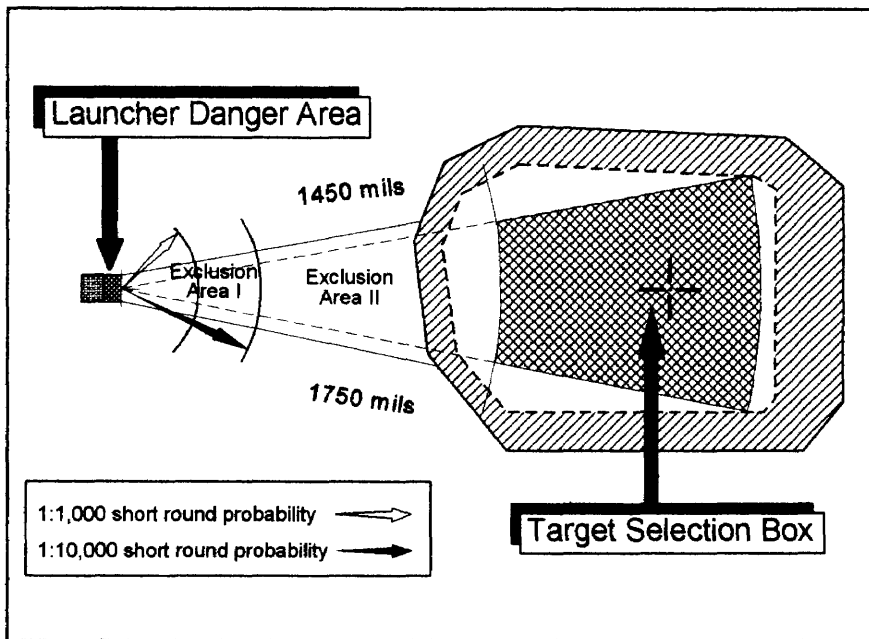

Figure J-4. Flight corridor.

**STEP 2.** The *Exclusion Area* is that area of the SDZ flight corridor within a specified distance of the downrange edge of the firing area. It is endangered by failure of the rocket motor (or early warhead event for the M28 rocket) during the boost phase. The distance is based on acceptance of risk (approved by the installation commander LAW AR 385-63).

*Exclusion Area I*

**STEP 2a.** Construct an arc, centered on the firing point, with a radius derived from Table J-3 (based on the level of accepted risk for Exclusion Area I). The area between the arc and the firing point is Exclusion Area I.

**Note:** The use of a 1:1,000 or 1:10,000 short round probability is used when calculating risk under waiver IAW AR 385-63.

Table J-3. Exclusion Areas

SHORT ROUND PROBABILITY	EXCLUSION AREA I		EXCLUSION AREA II		EXCLUSION AREA III	
	M28	M28A1	M28	M28A1	M28	M28A1
1 per 1,000 Firings	1,000 m	1,000 m	See Note 1	See Note 2	1,800 m (Note 3)	N/A
1 per 10,000 Firings	4,700 m	2,500 m	See Note 1	See Note 2	1,800 m (Note 3)	N/A

**Notes:** <sup>1</sup>This distance will vary based on range to target and the size of the impact area. It is the area between Exclusion Area I and Exclusion Area III.

<sup>2</sup>This distance will vary based on range to target and the size of the impact area. It is the area between Exclusion Area I and the SDZ impact area.

<sup>3</sup>This distance is measured from the near edge of the SDZ impact area toward the firing point.

*Exclusion Area II*

**STEP 2b.** The area between the arc of Exclusion Area I and the forward edge of the SDZ Impact Area is Exclusion Area II for the M28A1 Training Rocket (reduced range). Exclusion Area II for the M28 Training Rocket is that area between Exclusion Areas I and III.

**Note:** Exclusion Area II can only be occupied under waiver IAW AR 385-63. Exclusion Area I and III cannot be occupied.

*Exclusion Area III*

**STEP 2c.** This *Exclusion Area* applies only to the M26 Tactical and M28 Training Rockets. It is the area within the flight corridor that begins at the near edge of the SDZ impact area and extends 1,800 m toward the firing point.

The AZ and range limits determined in Phase I also describe a small area around the target. This is the target selection box. All targets selected from within this box will fall within the safety "T" for the firing point.

## OPAREA Method

### Phase I

Apply the SDZ requirements to the installation impact area (see Figure J-5):

**STEP 1.** Index the approximate geographic center of the installation impact area (target).

**STEP 2.** Index the center of the proposed firing OPAREA. Draw a circle around the index with a one kilometer radius. This distance may be larger or smaller depending upon the training area available to the unit.

**STEP 3.** Draw a line segment connecting the two indices from steps 1 and 2.

**STEP 4.** Apply the values of  $W_{max}$ ,  $X_{max}$ , and  $Y_{max}$  to the edges of the installation impact area (toward target). This is the *SDZ Impact Area*.

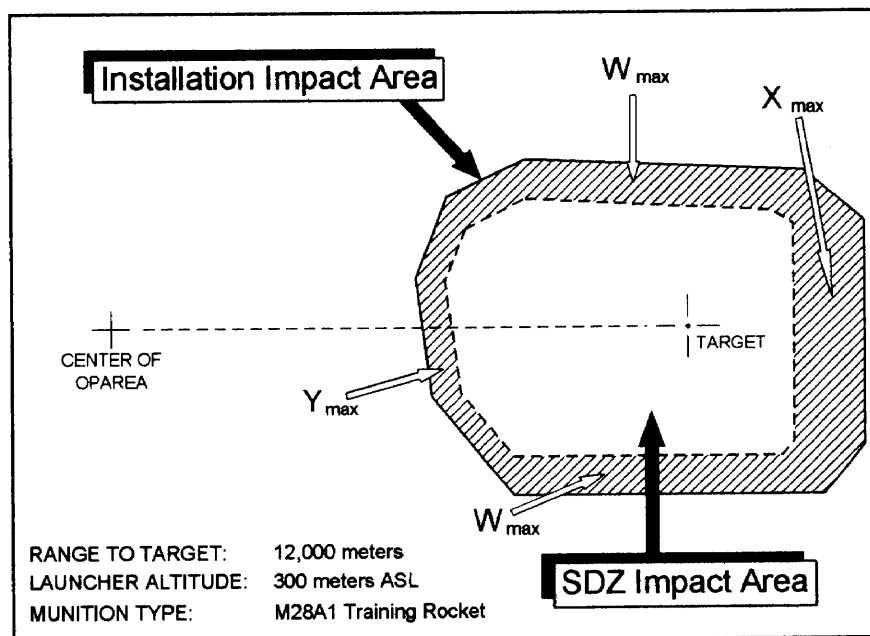

**Figure J-5. Impact area.**

# FM 6-60

## Phase II

*Determine the Left and Right Azimuth Limits of the OPAREA.*

**STEP 1.** Mark the most forward rearward, right, and left positions along the circumference of the OPAREA circle from Phase I.

**STEP 2.** Draw a safety fan from both the left and right positions (from step 1) which will keep all rounds within the SDZ Impact Area. You must also apply any azimuth restrictions imposed by the installation safety office for the firing area. Measure the left and right limits of each fan (see Figure J-6). These are the initial left and right azimuth limits for the entire live-fire OPAREA. (You will determine the final azimuth limits with FCS in step 8.)

**STEP 3.** Apply the lower (or leftmost) value of the *left* azimuth limits (derived from the leftmost position) to the rightmost position. Apply the higher (or rightmost) value of the *right* azimuth limits (derived from the rightmost position) to the leftmost position. Ensure these limits are marked separately and distinctly from the previous fans. They will be used to complete a “target selection box” later (see Figure J-7).

*Derive the Minimum and Maximum Values for Quadrant Elevation (QE).*

**STEP 4.** Measure the minimum and maximum ranges (2 each) from both the forward and rear OPAREA positions to the near and far edges of the SDZ impact area (within the azimuth limits). You must also consider minimum and maximum range limits imposed by the installation range safety office (Figure J-8).

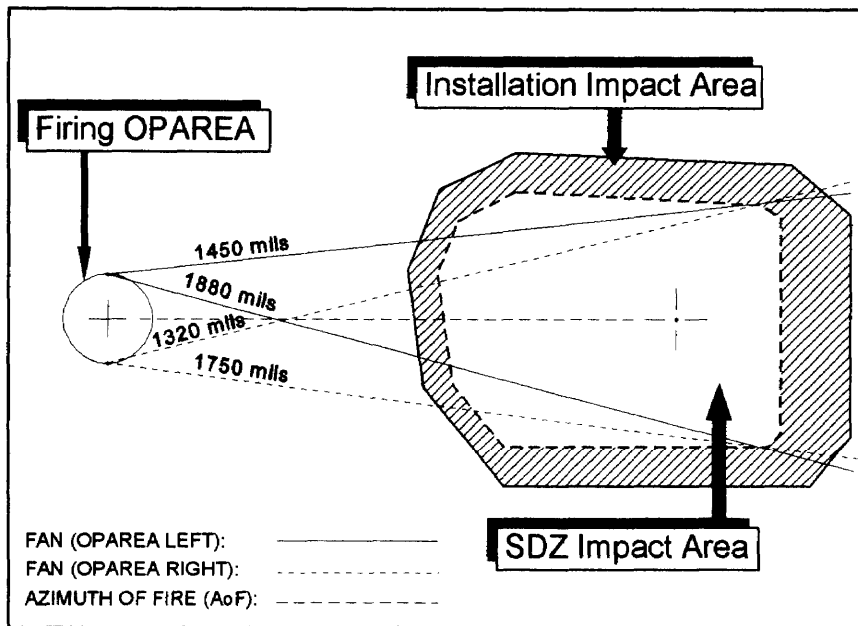

**Figure J-6. Azimuth limits for OPAREA.**

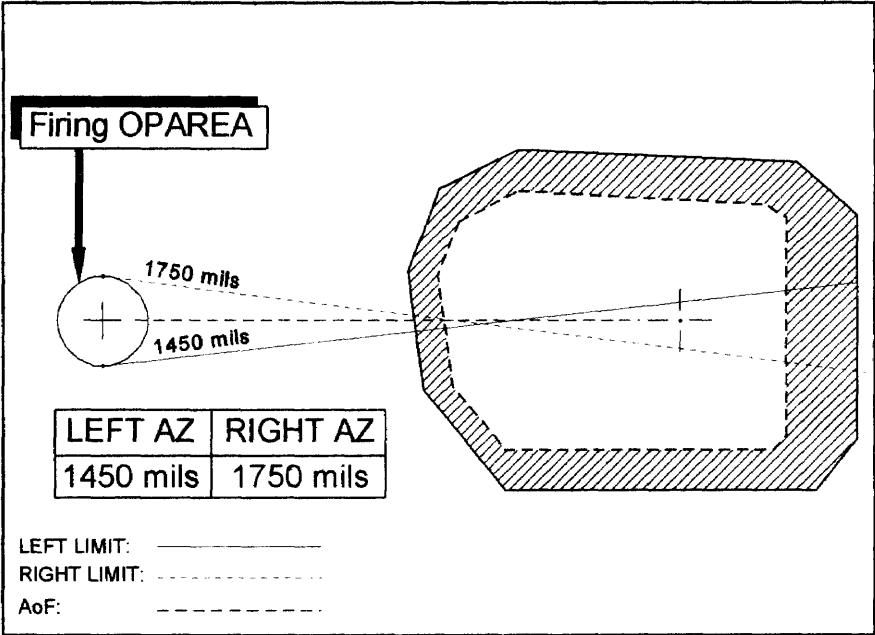

Figure J-7. Azimuth limits calculations.

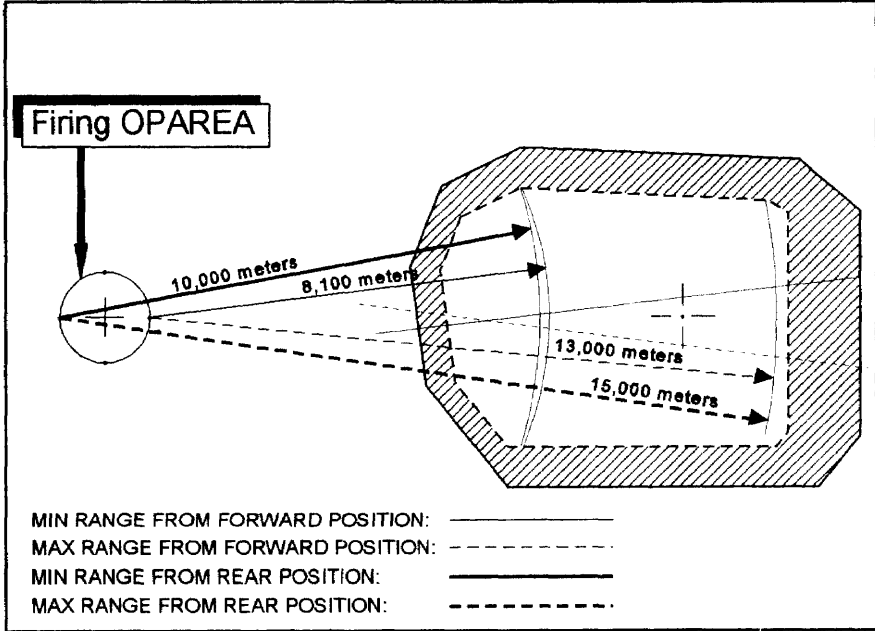

Figure J-8. Range limits calculations.



**FM 6-60**

**STEP 5.** Derive the OPAREA minimum range by applying the minimum range from the rear position of the OPAREA to the forward position of the OPAREA (Figure J-9).

**STEP 6.** Derive the OPAREA maximum range by applying the maximum range from the forward position of the OPAREA to the rear position of the OPAREA (Figure J-9).

**STEP 7.** Draw the associated range arcs, intersecting both the left and right azimuth limits from step 3.

**STEP 8.** Compute the safety T using the FCS with the current met to fire four dry missions from left, right, front, and rear OPAREA extremes as listed below.

**Mission 1.** Forward most OPAREA position to the lower left corner. This yields the min QE.

**Mission 2.** Rearward most OPAREA to the upper left corner. This yields the max QE.

**Mission 3.** Left most OPAREA to the lower right. This yields the right azimuth limit.

**Mission 4.** Right most OPAREA to the lower left corner. This yields the left azimuth limit.

This completes the safety "T" that establishes firing limits for the launcher within the OPAREA (Figure J-10).

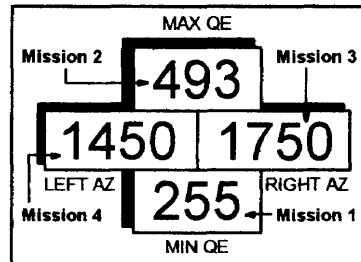

**Figure J-10. Safety T.**

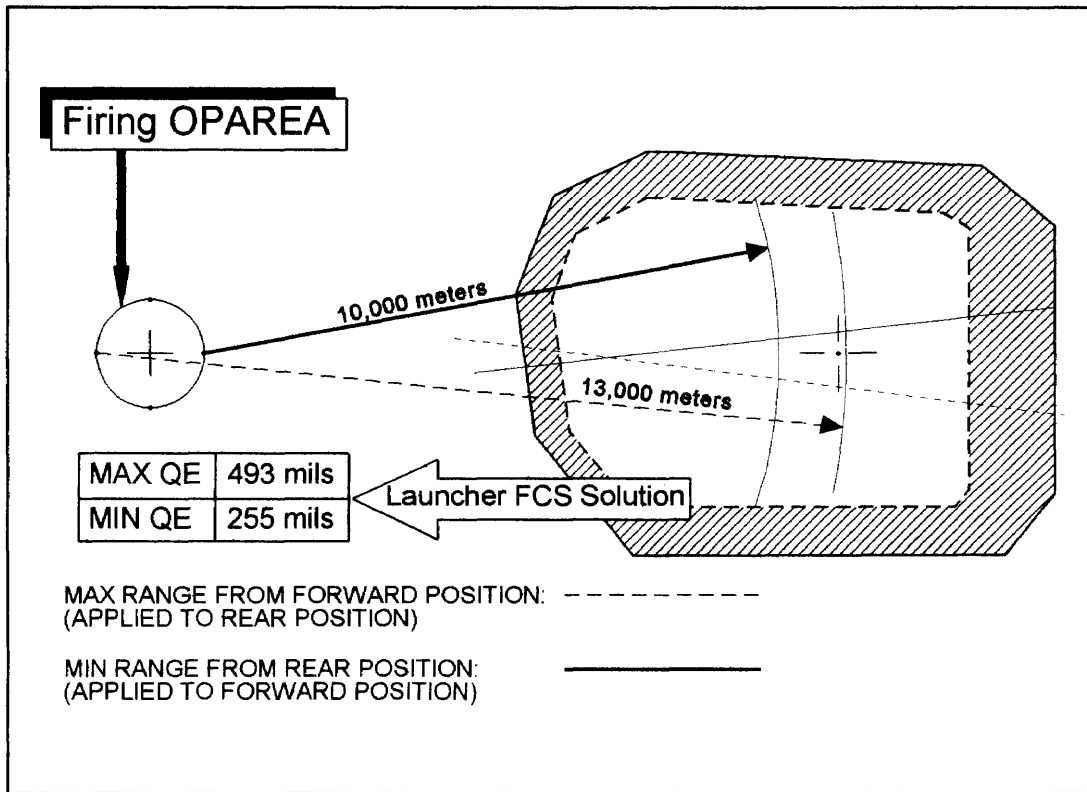
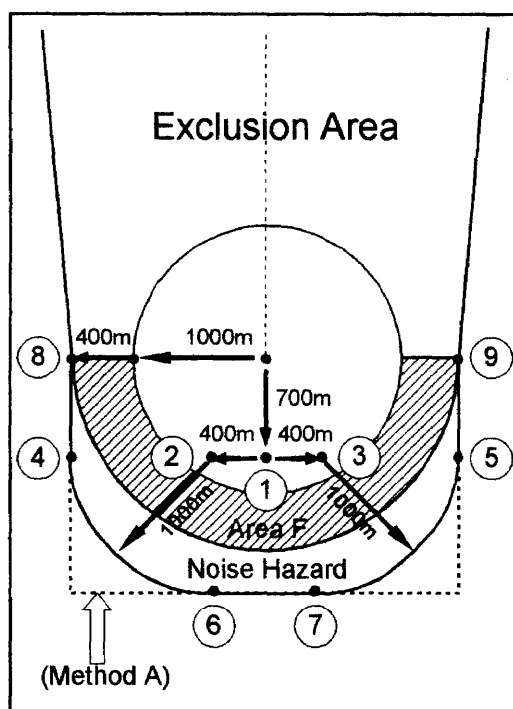

**Figure J-9. Quadrant elevation limits.**

**Phase III**

Apply the SDZ requirements (for the specific munition) to the launcher OPAREA and complete the flight corridor.

This phase applies the Launcher Danger Area (Area F) and Noise Hazard Area requirements to the OPAREA to determine a "worst case" diagram. This is accomplished by applying those requirements around the rear half of the circumference of the OPAREA (Figure J-11). Although these actual danger areas are a function of the specific launcher location, controlling entry to the areas derived in this phase will allow more freedom of movement for the launcher, thus adding realism to the live-fire training exercise.



**Figure J-11. OPAREA SDZ requirements.**

**STEP 1.** *Area F* (Launcher Danger Area) is the area immediately to the rear of the launcher which is directly exposed to blast and debris. Divide the OPAREA in half by drawing a line through its center, perpendicular to the AZ to the target constructed in Phase I. Extend outward along this line to a point 400 meters on each side around the rear half of the OPAREA. (See the shaded area of Figure J-11).

**STEP 2.** *The Noise Hazard Area (NHA)* extends an additional 300 meters behind Area F. It can only be

occupied by mission essential personnel wearing hearing protection. There are two means of constructing the NHA. The first is the most simple, while the second method minimizes the size of the NHA thus allowing less use of training land. To construct the OPAREA NHA:

**Method A:**

**STEP 2a.** Draw a box that extends 1400 meters to the left and right, as well as 1700 meters to the rear, of the center of the firing OPAREA. The result is a box 2800 meters wide and 1700 meters deep. Go to Phase IV.

**Method B:**

**STEP 2b.** Place an index at a point 700 meters to the rear of the center of the OPAREA along the AoF (see Figure J-11, point number 1).

**STEP 3b.** Place two more indices 400 meters to the left and right of the first index, perpendicular to the AoF (points 2 and 3).

**STEP 4b.** From each of these last two indices, construct a 1000 meter radius arc through points 4 and 5 respectively (1600 mils).

**STEP 5b.** From points 4 and 5 extend line segments forward so that they are tangent to Area F at points 8 and 9 respectively.

**STEP 6b.** Connect the two arcs in the rear (between points 6 and 7) with a line segment to complete the rear edge of the NHA.

**Phase IV**

**STEP 1.** Construct line segments from points 8 and 9 forward to the rear edge of the Installation Impact Area. The line segments should be parallel to the left and right azimuth limits respectively. Since these line segments begin at points 400 m to the left and right of the OPAREA, Danger Area A (320m) has been accounted for. This describes the general flight corridor (see Figure J-12, page J-12).

**STEP 2.** *The Exclusion Area* is that area of the SDZ flight corridor within a specified distance of the far edge of the firing area. It is endangered by failure of the rocket motor during the boost phase. The distance is based on acceptance of risk (approved by the installation commander IAW AR 385-63).

*Exclusion Area I*

**STEP 2a.** Construct an arc, from the center of the OPAREA, with a radius that extends beyond the OPAREA by the distance in Table J-3, page J-6 (based on the level of accepted risk for Exclusion Area I). The area between the arc and the front of the OPAREA is Exclusion Area I. The example in Figure J-13, shows both a 1:10,000 short round probability (2,500 m) and a 1:1,000 short round probability (1,000 m). The use of a 1:1,000 level of acceptable risk must be done under waiver IAW AR 385-63.

*Exclusion Area II*

**STEP 2b.** The area between the arc of Exclusion Area I and the front of the OPAREA is Exclusion Area II for the

M28A1 Training Rocket (reduced range). Exclusion Area II for the M28 Training Rocket is that area between Exclusion Areas I and III. Exclusion Area II can only be occupied under waiver IAW AR 385-63. Exclusion Area I and III cannot be occupied.

*Exclusion Area III*

**STEP 2c.** This *Exclusion Area* applies only to the M26 Tactical and M28 Training Rockets. It is the area within the flight corridor that begins at the near edge of the SDZ impact area and extends 1,800 m toward the firing point.

The AZ and range limits determined in steps 3 and 6 of Phase II also describe a small area around the target. This is the target selection box. All targets selected from within this box will fall within the safety "T" for the live-fire OPAREA (Figure J-12).

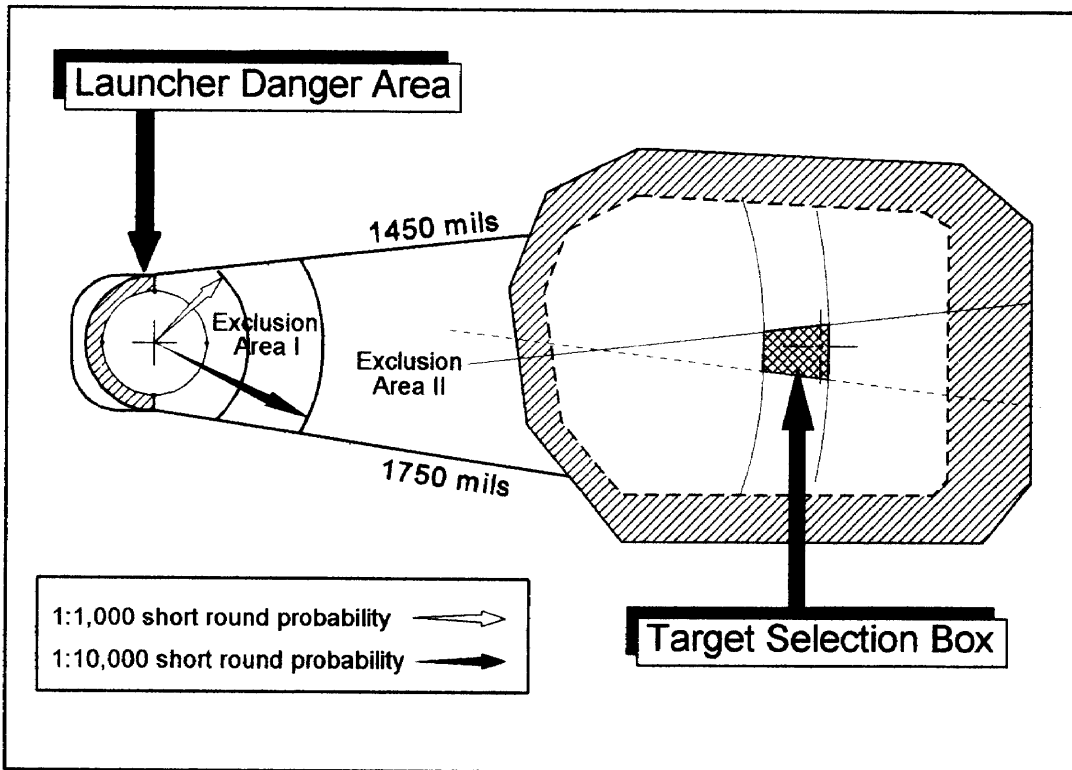

**Figure J-12. Exclusion areas.**

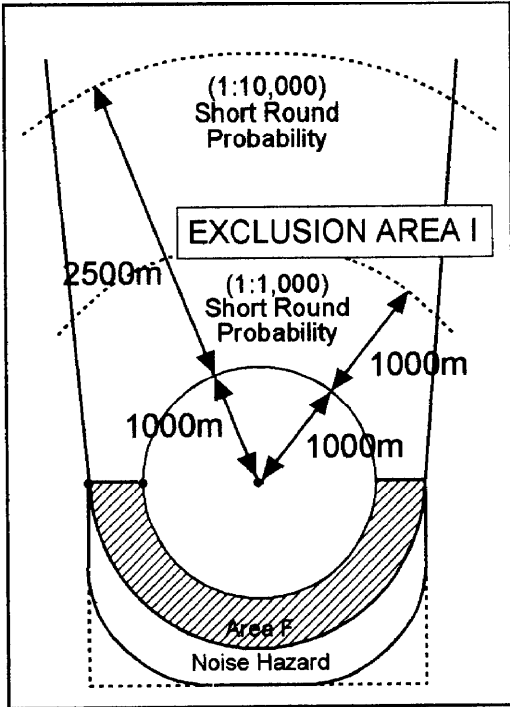

Figure J-13. Exclusion Area I.

## APPENDIX K

**M26/M28 AND M28A1 ROCKET BALLISTIC ALGORITHM SOLUTIONS**

All firings are sea level launches using standard meteorological data.

**M26 and M28 Rocket Ballistic Algorithm Solutions**

AIM			WARHEAD EVENT				APOGEE		
Range to Target (m)	Dud Fuze (m)	QE (mils)	Fuze Setting (sec)	HOB (m)	Range (m)	Payload Time to Impact (sec)	Altitude (m)	Range (m)	Time (sec)
10,000	13,530	161.78	14.33	533	9,480	32.13	584	7,551	11.26
10,100	13,530	161.78	14.51	528	9,581	32.13	584	7,551	11.26
10,200	13,530	161.78	14.70	522	9,682	32.12	584	7,551	11.26
10,300	13,530	161.78	14.89	515	9,784	32.09	584	7,551	11.26
10,400	13,530	161.78	15.07	509	9,885	32.06	584	7,551	11.26
10,500	13,530	161.78	15.26	502	9,987	32.03	584	7,551	11.26
10,600	13,530	161.78	15.46	494	10,089	31.98	584	7,551	11.26
10,700	13,530	161.78	15.65	486	10,190	31.92	584	7,551	11.26
10,800	13,530	161.78	15.84	478	10,292	31.86	584	7,551	11.26
10,900	13,530	161.78	16.03	470	10,394	31.79	584	7,551	11.26
11,000	13,530	161.78	16.23	461	10,496	31.71	584	7,551	11.26
11,100	13,530	161.78	16.43	451	10,598	31.61	584	7,551	11.26
11,200	13,535	161.87	16.63	443	10,700	31.54	584	7,551	11.26
11,300	13,601	162.95	16.82	444	10,802	31.75	592	7,550	11.26
11,400	13,667	164.04	17.02	446	10,902	31.96	601	7,702	11.51
11,500	13,733	165.15	17.22	447	11,003	32.16	609	7,701	11.51
11,600	13,799	166.27	17.42	449	11,103	32.37	618	7,701	11.51
11,700	13,866	167.42	17.63	450	11,204	32.58	627	7,851	11.76
11,800	13,933	168.58	17.83	452	11,306	32.79	636	7,851	11.76
11,900	14,002	169.74	18.04	453	11,407	33.01	645	7,850	11.76
12,000	14,071	170.93	18.24	455	11,508	33.22	654	7,849	11.76
12,100	14,139	172.13	18.45	456	11,608	33.43	663	7,998	12.01

M26 and M28 Rocket Ballistic Algorithm Solutions (Continued)

AIM			WARHEAD EVENT				APOGEE		
Range to Target (m)	Dud Fuze (m)	QE (mils)	Fuze Setting (sec)	HOB (m)	Range (m)	Payload Time To Impact (sec)	Altitude (m)	Range (m)	Time (sec)
12,200	14,209	173.35	18.66	458	11,709	33.65	673	7,997	12.01
12,300	14,280	174.59	18.87	459	11,811	33.86	683	7,996	12.01
12,400	14,350	175.83	19.08	461	11,911	34.08	693	8,145	12.26
12,500	14,422	177.10	19.29	462	12,012	34.30	703	8,144	12.26
12,600	14,492	178.37	19.51	464	12,113	34.52	713	8,143	12.26
12,700	14,565	179.67	19.72	465	12,214	34.74	724	8,290	12.51
12,800	14,638	180.98	19.94	467	12,315	34.96	734	8,289	12.51
12,900	14,711	182.30	20.16	468	12,416	35.18	745	8,288	12.51
13,000	14,783	183.60	20.38	470	12,517	35.40	756	8,433	12.76
13,100	14,858	185.00	20.60	472	12,618	35.63	768	8,432	12.76
13,200	14,932	186.38	20.82	473	12,719	35.86	779	8,431	12.76
13,300	15,007	187.77	21.04	475	12,820	36.08	791	8,575	13.01
13,400	15,083	189.20	21.27	477	12,921	36.32	803	8,574	13.01
13,500	15,160	190.67	21.49	479	13,023	36.56	816	8,573	13.01
13,600	15,238	192.15	21.72	481	13,124	36.81	828	8,716	13.26
13,700	15,316	193.63	21.95	483	13,225	37.05	841	8,715	13.26
13,800	15,395	195.14	22.18	485	13,325	37.30	854	8,713	13.26
13,900	15,473	196.66	22.41	487	13,426	37.54	867	8,855	13.51
14,000	15,552	198.20	22.64	489	13,527	37.79	881	8,854	13.51
14,100	15,632	199.75	22.87	491	13,629	38.04	895	8,852	13.51
14,200	15,712	201.32	23.11	493	13,729	38.29	908	8,993	13.76
14,300	15,792	202.91	23.34	495	13,831	38.55	923	8,991	13.76
14,400	15,872	204.51	23.58	497	13,932	38.80	937	8,990	13.76
14,500	15,953	206.13	23.82	499	14,033	39.05	952	9,129	14.01
14,600	16,033	207.76	24.06	501	14,134	39.30	966	9,128	14.01
14,700	16,114	209.41	24.30	503	14,235	39.56	981	9,266	14.26

## M26 and M28 Rocket Ballistic Algorithm Solutions (Continued)

AIM			WARHEAD EVENT				APOGEE		
Range to Target (m)	Dud Fuze (m)	QE (mils)	Fuze Setting (sec)	HOB (m)	Range (m)	Payload Time to Impact (sec)	Altitude (m)	Range (m)	Time (sec)
14,800	16,196	211.08	24.54	506	14,336	39.82	997	9,264	14.26
14,900	16,277	212.76	24.79	508	14,437	40.08	1,012	9,262	14.26
15,000	16,358	214.45	25.04	510	14,538	40.33	1,028	9,400	14.51
15,100	16,441	216.15	25.28	512	14,639	40.60	1,044	9,398	14.51
15,200	16,523	217.89	25.53	514	14,740	40.86	1,060	9,534	14.76
15,300	16,606	219.62	25.78	516	14,841	41.12	1,077	9,532	14.76
15,400	16,689	221.38	26.03	518	14,943	41.38	1,093	9,530	14.76
15,500	16,772	223.17	26.28	520	15,044	41.65	1,110	9,665	15.01
15,600	16,856	224.96	26.54	522	15,145	41.91	1,128	9,663	15.01
15,700	16,939	226.77	26.79	524	15,246	42.18	1,145	9,797	15.26
15,800	17,023	228.61	27.05	526	15,347	42.45	1,163	9,795	15.26
15,900	17,107	230.45	27.31	528	15,548	42.72	1,181	9,792	15.26
16,000	17,191	232.31	27.57	531	15,550	42.99	1,200	9,925	15.51
16,100	17,276	234.19	27.83	533	15,651	43.26	1,218	9,923	15.51
16,200	17,361	236.09	28.09	535	15,753	43.53	1,237	10,054	15.76
16,300	17,446	238.00	28.36	537	15,854	43.81	1,256	10,052	15.76
16,400	17,531	239.93	28.62	539	15,955	44.08	1,275	10,183	16.01
16,500	17,617	241.88	28.89	541	16,056	44.36	1,295	10,180	16.01
16,600	17,702	243.84	29.16	543	16,157	44.64	1,315	10,177	16.01
16,700	17,789	245.82	29.43	545	16,258	44.92	1,336	10,307	16.26
16,800	17,875	247.81	29.70	547	16,360	45.19	1,356	10,304	16.26
16,900	17,960	249.83	29.97	549	16,461	45.48	1,377	10,433	16.51
17,000	18,046	251.86	30.25	551	16,562	45.76	1,398	10,430	16.51
17,100	18,134	253.90	30.52	553	16,664	46.04	1,420	10,557	16.76
17,200	18,220	255.97	30.80	555	16,765	46.33	1,441	10,554	16.76
17,300	18,308	258.06	31.08	557	16,866	46.62	1,463	10,551	16.76

M26 and M28 Rocket Ballistic Algorithm Solutions (Continued)

AIM			WARHEAD EVENT				APOGEE		
Range to Target (m)	Dud Fuze (m)	QE (mils)	Fuze Setting (sec)	HOB (m)	Range (m)	Payload Time to Impact (sec)	Altitude (m)	Range (m)	Time (sec)
17,400	18,395	260.16	31.36	560	16,967	46.91	1,486	10,678	17.01
17,500	18,483	262.29	31.64	562	17,069	47.20	1,509	10,674	17.01
17,600	18,570	264.42	31.92	564	17,170	47.48	1,532	10,800	17.26
17,700	18,658	266.58	32.21	566	17,272	47.77	1,555	10,796	17.26
17,800	18,746	268.75	32.49	568	17,373	48.06	1,579	10,921	17.51
17,900	188.34	270.95	32.78	570	17,474	48.36	1,603	10,917	17.51
18,000	18,923	273.16	33.07	572	17,576	48.66	1,627	11,041	17.76
18,100	19,011	275.38	33.36	574	17,677	48.96	1,652	11,037	17.76
18,200	19,099	277.62	33.65	576	17,779	49.24	1,677	11,159	18.01
18,300	19,188	279.89	33.94	578	17,880	49.55	1,702	11,156	18.01
18,400	19,278	282.17	34.23	580	17,981	49.85	1,728	11,277	18.26
18,500	19,367	284.46	34.53	582	18,083	50.15	1,754	11,273	18.26
18,600	19,456	286.78	34.83	584	18,184	50.46	1,780	11,394	18.51
18,700	19,545	289.11	35.13	586	18,286	50.75	1,807	11,389	18.51
18,800	19,636	291.46	35.43	588	18,387	51.06	1,834	11,510	18.76
18,900	19,725	293.83	35.73	590	18,488	51.37	1,861	11,505	18.76
19,000	19,815	296.22	36.03	592	18,590	51.68	1,889	11,624	19.01
19,100	19,905	298.63	36.34	594	18,692	51.99	1,917	11,619	19.01
19,200	19,995	301.06	36.64	596	18,793	52.30	1,946	11,737	19.26
19,300	20,086	303.51	36.95	598	18,895	52.61	1,975	11,732	19.26
19,400	20,176	305.98	37.26	601	18,996	52.93	2,004	11,849	19.51
19,500	20,267	308.48	37.57	603	19,097	53.25	2,034	11,844	19.51
19,600	20,358	310.98	37.88	605	19,199	53.56	2,064	11,960	19.76
19,700	20,449	313.51	38.20	607	19,301	53.88	2,094	11,955	19.76
19,800	20,540	316.06	38.51	609	19,402	54.20	2,125	12,069	20.01
19,900	20,631	318.62	38.83	611	19,504	54.53	2,157	12,064	20.01



## M26 and M28 Rocket Ballistic Algorithm Solutions (Continued)

AIM			WARHEAD EVENT				APOGEE		
Range to Target (m)	Dud Fuze (m)	QE (mils)	Fuze Setting (sec)	HOB (m)	Range (m)	Payload Time to Impact (sec)	Altitude (m)	Range (m)	Time (sec)
20,000	20,722	321.20	39.15	613	19,605	54.84	2,188	12,178	20.26
20,100	20,814	323.80	39.47	615	19,707	55.17	2,220	12,172	20.26
20,200	20,905	326.41	39.79	617	19,808	55.49	2,253	12,285	20.51
20,300	20,998	329.05	40.11	619	19,910	55.82	2,286	12,280	20.51
20,400	21,090	331.71	40.44	621	20,011	56.15	2,319	12,392	20.76
20,500	21,182	334.39	40.76	623	20,113	56.48	2,353	12,386	20.76
20,600	21,274	337.09	41.09	625	20,214	56.82	2,387	12,497	21.01
20,700	21,367	339.81	41.42	627	20,316	57.15	2,421	12,490	21.01
20,800	21,459	342.54	41.75	629	20,418	57.48	2,456	12,601	21.26
20,900	21,551	345.30	42.08	631	20,519	57.82	2,492	12,710	21.51
21,000	21,644	348.07	42.41	633	20,621	58.15	2,527	12,703	21.51
21,100	21,737	350.87	42.75	636	20,722	58.50	2,564	12,812	21.76
21,200	21,829	353.68	43.08	638	20,824	58.84	2,600	12,805	21.76
21,300	21,923	356.52	43.42	640	20,925	59.18	2,638	12,912	22.01
21,400	22,016	359.38	43.76	642	21,027	59.53	2,675	12,905	22.01
21,500	22,109	362.25	44.10	644	21,129	59.88	2,713	13,012	22.26
21,600	22,202	365.13	44.44	646	21,230	60.22	2,752	13,118	22.51
21,700	22,297	368.04	44.79	648	21,333	60.57	2,791	13,110	22.51
21,800	22,390	370.94	45.13	649	21,434	60.91	2,830	13,216	22.76
21,900	22,484	373.90	45.48	652	21,535	61.28	2,870	13,207	22.76
22,000	22,765	382.87	46.53	658	21,840	62.34	2,992	13,406	23.26
22,100	22,671	379.86	46.18	656	21,739	61.97	2,951	13,303	23.01
22,200	22,765	382.87	46.53	658	21,840	62.34	2,992	13,406	23.26
22,300	22,860	385.91	46.88	660	21,941	62.70	3,034	13,509	23.51
22,400	22,954	388.96	47.23	662	22,043	63.06	3,076	13,500	23.51
22,500	23,048	392.04	47.50	664	22,145	63.43	3,119	13,601	23.76

M26 and M28 Rocket Ballistic Algorithm Solutions (Continued)

AIM			WARHEAD EVENT				APOGEE		
Range to Target (m)	Dud Fuze (m)	QE (mils)	Fuze Setting (sec)	HOB (m)	Range (m)	Payload Time to Impact (sec)	Altitude (m)	Range (m)	Time (sec)
22,600	23,142	395.12	47.95	666	22,247	63.78	3,162	13,592	23.76
22,700	23,237	398.23	48.31	668	22,348	64.15	3,206	13,692	24.01
22,800	23,332	401.37	48.67	670	22,450	64.52	3,250	13,792	24.26
22,900	23,427	404.52	49.03	673	22,551	64.90	3,295	13,782	24.26
23,000	23,522	407.69	49.39	675	22,654	65.27	3,340	13,882	24.51
23,100	23,616	410.87	49.76	677	22,755	65.64	3,386	13,871	24.51
23,200	23,711	414.10	50.13	679	22,857	66.01	3,432	13,969	24.76
23,300	23,806	417.34	50.49	681	22,958	66.39	3,479	14,066	25.01
23,400	23,901	420.60	50.86	683	23,059	66.77	3,527	14,055	25.01
23,500	23,997	423.89	51.24	685	23,161	67.16	3,575	14,151	25.26
23,600	24,091	427.19	51.61	687	23,365	67.92	3,672	14,330	25.76
23,700	24,186	430.51	51.99	689	23,365	67.92	3,672	14,235	25.51
23,800	24,283	433.87	52.36	691	23,466	68.31	3,722	14,330	25.76
23,900	24,378	437.24	52.74	694	23,568	68.70	3,772	14,424	26.01
24,000	24,473	440.63	53.12	695	23,669	69.08	3,823	14,411	26.01
24,100	24,568	444.02	53.50	697	23,770	69.47	3,874	14,504	26.26
24,200	24,664	447.46	53.89	699	23,872	69.86	3,926	14,490	26.26
24,300	24,761	450.93	54.28	702	23,975	70.28	3,979	14,583	26.51
24,400	24,856	454.38	54.66	704	24,076	70.66	4,031	14,674	26.76
24,500	24,952	457.90	55.05	706	24,178	71.06	4,085	14,660	26.76
24,600	25,048	461.43	55.44	708	24,279	71.47	4,140	14,750	27.01
24,700	25,144	464.99	55.84	710	24,381	71.87	4,195	14,839	27.26
24,800	25,240	468.56	56.23	712	24,483	72.28	4,250	14,824	27.26
24,900	25,336	472.16	56.63	714	24,584	72.68	4,306	14,912	27.51
25,000	25,432	475.80	57.03	717	24,686	73.11	4,363	15,000	27.76
25,100	25,529	479.45	57.43	718	24,788	73.51	4,421	15,086	28.01

## M26 and M28 Rocket Ballistic Algorithm Solutions (Continued)

AIM			WARHEAD EVENT				APOGEE		
Range to Target (m)	Dud Fuze (m)	QE (mils)	Fuze Setting (sec)	HOB (m)	Range (m)	Payload Time to Impact (sec)	Altitude (m)	Range (m)	Time (sec)
25,200	25,625	483.13	57.83	720	24,889	73.93	4,479	15,070	28.01
25,300	25,721	486.81	58.24	722	24,990	74.35	4,538	15,155	28.26
25,400	25,818	490.53	58.65	724	25,093	74.76	4,597	15,241	28.51
25,500	25,915	494.28	59.05	727	25,194	75.19	4,657	15,223	28.51
25,600	26,011	498.04	59.46	728	25,296	75.60	4,718	15,307	28.76
25,700	26,108	501.84	59.88	731	25,398	73.06	4,780	15,390	29.01
25,800	26,204	505.67	60.29	733	25,499	76.47	4,842	15,371	29.01
25,900	26,301	509.53	60.71	735	25,601	76.90	4,905	15,452	29.26
26,000	26,397	513.41	61.13	737	25,702	77.33	4,968	15,533	29.51
26,100	26,494	517.33	61.55	739	25,804	77.77	5,033	15,613	29.76
26,200	26,591	521.25	61.98	741	25,906	78.19	5,098	15,592	29.76
26,300	26,688	525.22	62.40	743	26,007	78.65	5,164	15,671	30.01
26,400	26,784	529.18	62.83	745	26,108	79.08	5,230	15,750	30.26
26,500	26,881	533.20	63.26	747	26,210	79.52	5,297	15,827	30.51
26,600	26,980	537.25	63.69	750	26,312	79.99	5,366	15,805	30.51
26,700	27,077	541.31	64.13	752	26,413	80.44	5,435	15,881	30.76
26,800	27,175	545.46	64.57	755	26,516	80.92	5,505	15,955	31.01
26,900	27,274	549.66	65.01	759	26,617	81.42	5,577	16,029	31.26
27,000	27,372	553.89	65.45	762	26,718	81.92	5,650	16,004	31.26
27,100	27,470	558.15	65.90	766	26,820	82.41	5,723	16,076	31.51
27,200	27,568	562.47	66.35	769	26,921	82.92	5,798	16,147	31.76
27,300	27,666	566.82	66.81	772	27,023	83.41	5,874	16,217	32.01
27,400	27,765	571.22	67.27	776	27,125	83.93	5,950	16,286	32.26
27,500	27,862	575.63	67.73	779	27,225	84.45	6,028	16,257	32.26
27,600	27,960	580.09	68.19	782	27,327	84.95	6,107	16,325	32.51
27,700	28,059	584.60	68.66	786	27,429	85.48	6,186	16,391	32.76

M26 and M28 Rocket Ballistic Algorithm Solutions (Continued)

AIM			WARHEAD EVENT				APOGEE		
Range to Target (m)	Dud Fuze (m)	QE (mils)	Fuze Setting (sec)	HOB (m)	Range (m)	Payload Time to Impact (sec)	Altitude (m)	Range (m)	Time (sec)
27,800	28,158	589.15	69.13	790	27,531	86.01	6,267	16,457	33.01
27,900	28,256	593.71	69.61	793	27,632	86.52	6,349	16,521	33.26
28,000	28,354	598.35	70.09	796	27,734	87.06	6,432	16,584	33.51
28,100	28,453	603.02	70.57	799	27,836	87.58	6,516	16,646	33.76
28,200	28,551	607.76	71.06	803	27,937	88.13	6,602	16,611	33.76
28,300	28,649	612.53	71.55	806	28,039	88.66	6,688	16,671	34.01
28,400	28,748	617.37	72.05	810	28,140	89.22	6,776	16,729	34.26
28,500	28,845	622.20	72.54	813	28,241	89.76	6,865	16,787	34.51
28,600	28,943	627.16	73.05	816	28,343	90.31	6,956	16,842	34.76
28,700	29,043	632.17	73.56	821	28,445	90.90	7,049	16,897	35.01
28,800	29,142	637.23	74.08	824	28,547	91.47	7,143	16,950	35.26
28,900	29,239	642.29	74.60	827	28,648	92.03	7,237	17,002	35.51
29,000	29,337	647.48	75.13	830	28,750	92.61	7,334	17,052	35.76
29,100	29,437	652.76	75.66	834	28,852	93.21	7,434	17,100	36.01
29,200	29,536	658.10	76.21	837	28,954	93.79	7,534	17,146	36.26
29,300	29,634	663.53	76.75	841	29,056	94.39	7,6373	17,191	36.51
29,400	29,732	669.01	77.31	844	29,157	94.99	7,741	17,233	36.76
29,500	29,830	674.64	77.88	847	29,258	95.61	7,849	17,274	37.01
29,600	29,929	680.39	78.45	851	29,361	96.25	7,959	17,312	37.26
29,700	30,027	686.22	79.04	854	29,462	96.88	8,072	17,348	37.51
29,800	30,125	692.14	79.63	858	29,564	97.53	8,186	17,382	37.76
29,900	30,223	698.21	80.24	861	29,666	98.17	8,304	17,413	38.01
30,000	30,322	704.43	80.86	864	29,768	98.85	8,425	17,441	38.26
30,100	30,421	710.78	81.49	868	29,870	99.54	8,550	17,467	38.51
30,200	30,519	717.31	82.13	871	29,972	100.24	8,678	17,577	39.01
30,300	30,616	723.93	82.79	874	30,073	100.93	8,809	17,596	39.26

## M26 and M28 Rocket Ballistic Algorithm Solutions (Continued)

AIM			WARHEAD EVENT				APOGEE		
Range to Target (m)	Dud Fuze (m)	QE (mils)	Fuze Setting (sec)	HOB (m)	Range (m)	Payload Time to Impact (sec)	Altitude (m)	Range (m)	Time (sec)
30,400	30,713	730.82	83.47	878	30,174	101.66	8,946	17,611	39.51
30,500	30,814	737.93	84.17	882	30,278	102.43	9,088	17,622	39.76
30,600	30,912	745.26	84.89	885	30,380	103.19	9,234	17,715	40.26
30,700	31,009	752.83	85.63	889	30,482	103.98	9,386	17,715	40.51
30,800	31,108	760.79	86.40	892	30,585	104.80	9,546	17,709	40.76
30,900	31,206	769.11	87.21	896	30,688	105.66	9,715	17,782	41.26
31,000	31,303	777.86	88.05	899	30,790	106.54	9,893	17,846	41.76
31,200	31,499	797.16	89.91	906	30,996	108.48	10,288	17,855	42.51
31,300	31,597	808.09	90.95	910	31,100	109.57	10,513	17,878	43.01
31,400	31,692	820.15	92.09	913	31,203	110.74	10,762	17,879	43.51
31,500	31,788	834.06	93.40	918	31,306	112.09	11,051	17,930	44.26
31,600	31,883	850.76	94.96	920	31,410	113.65	11,399	17,928	45.01
31,700	31,992	879.36	97.58	929	31,533	116.38	12,000	17,881	46.26

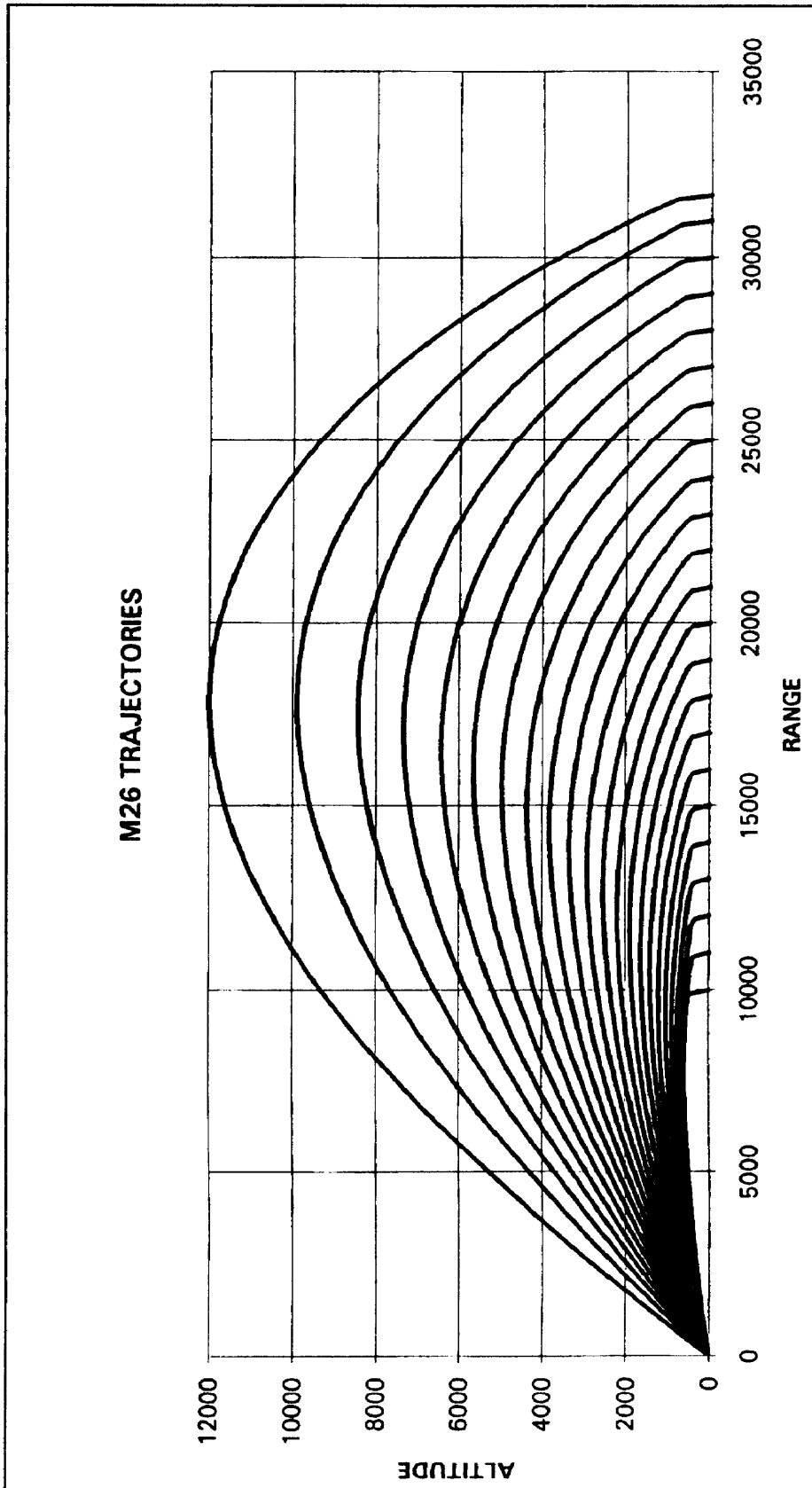

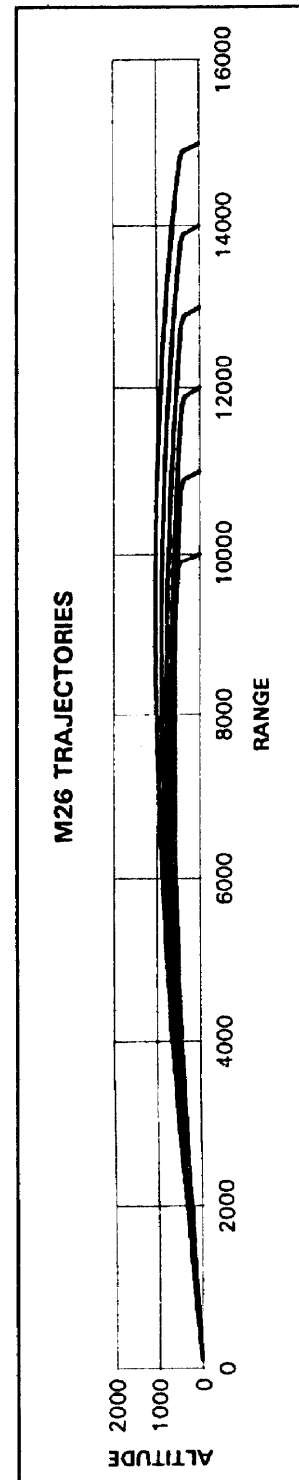

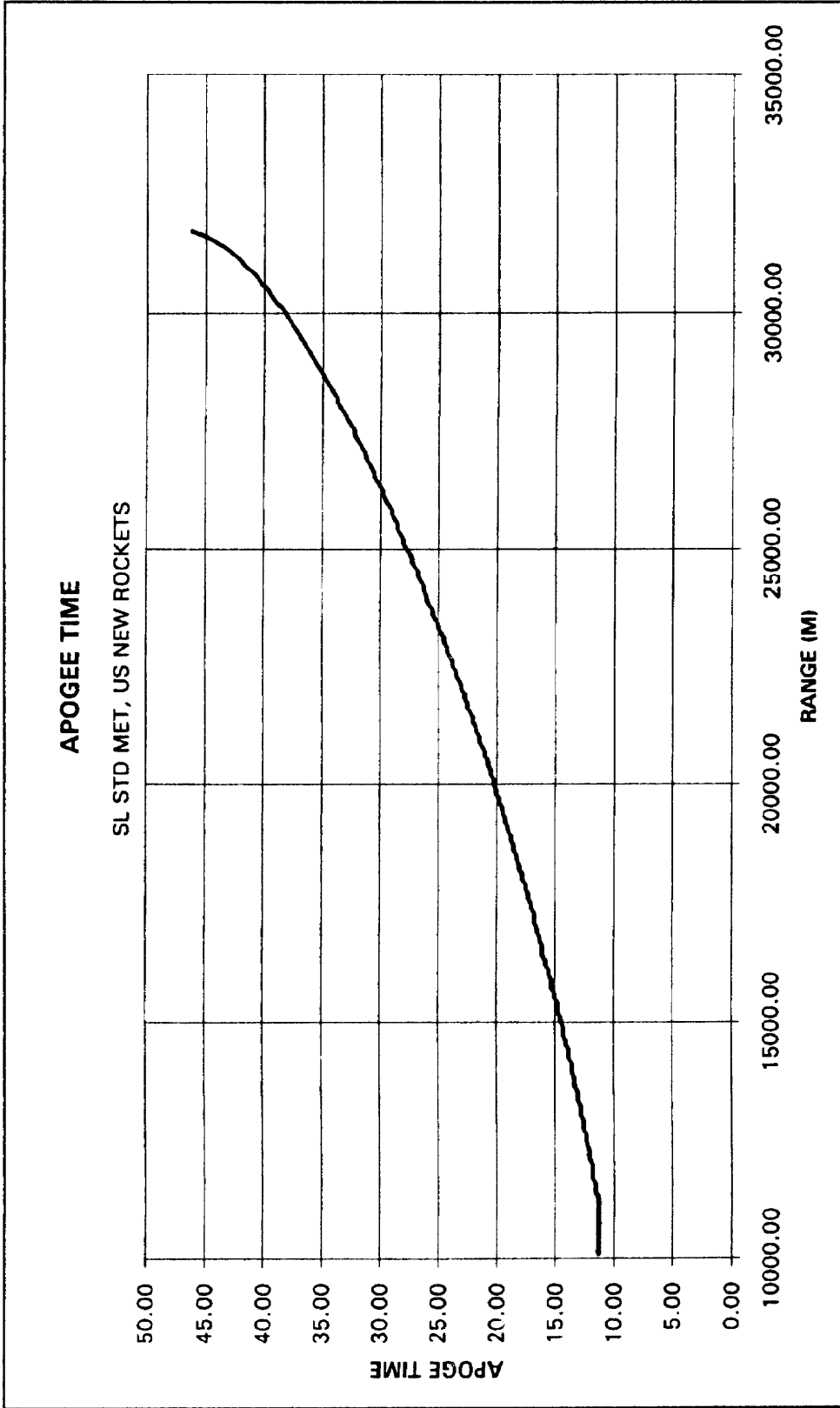



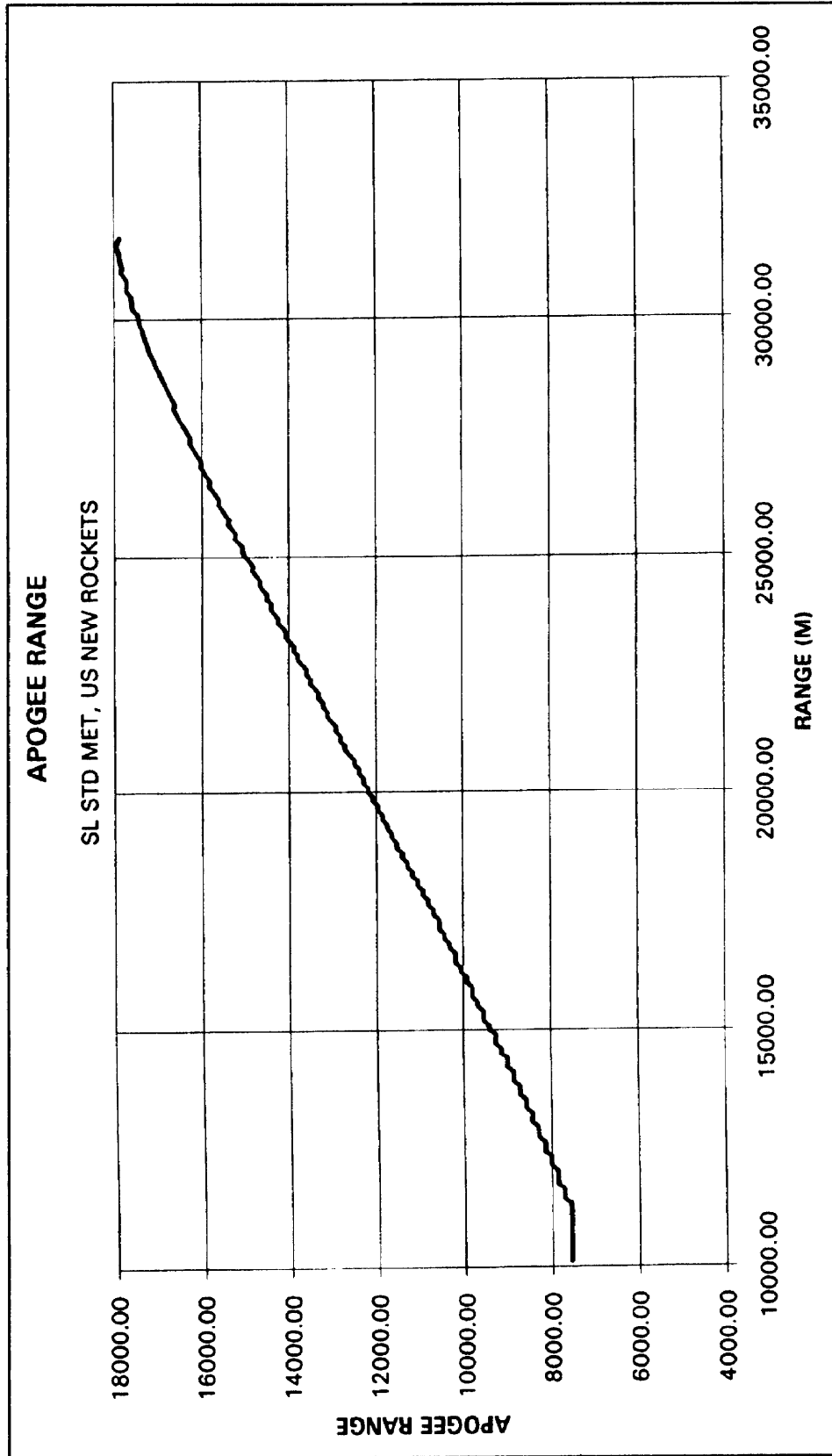

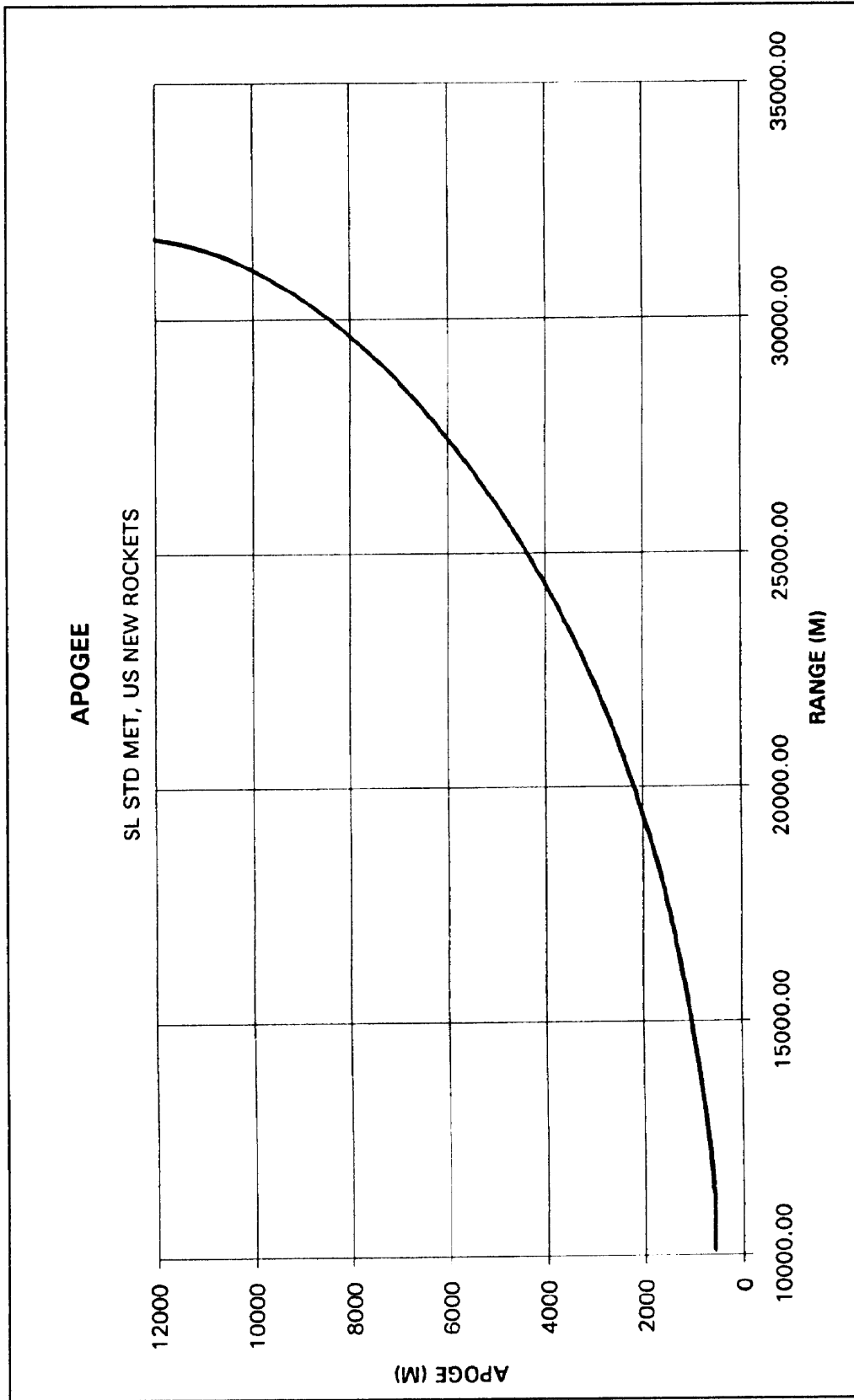

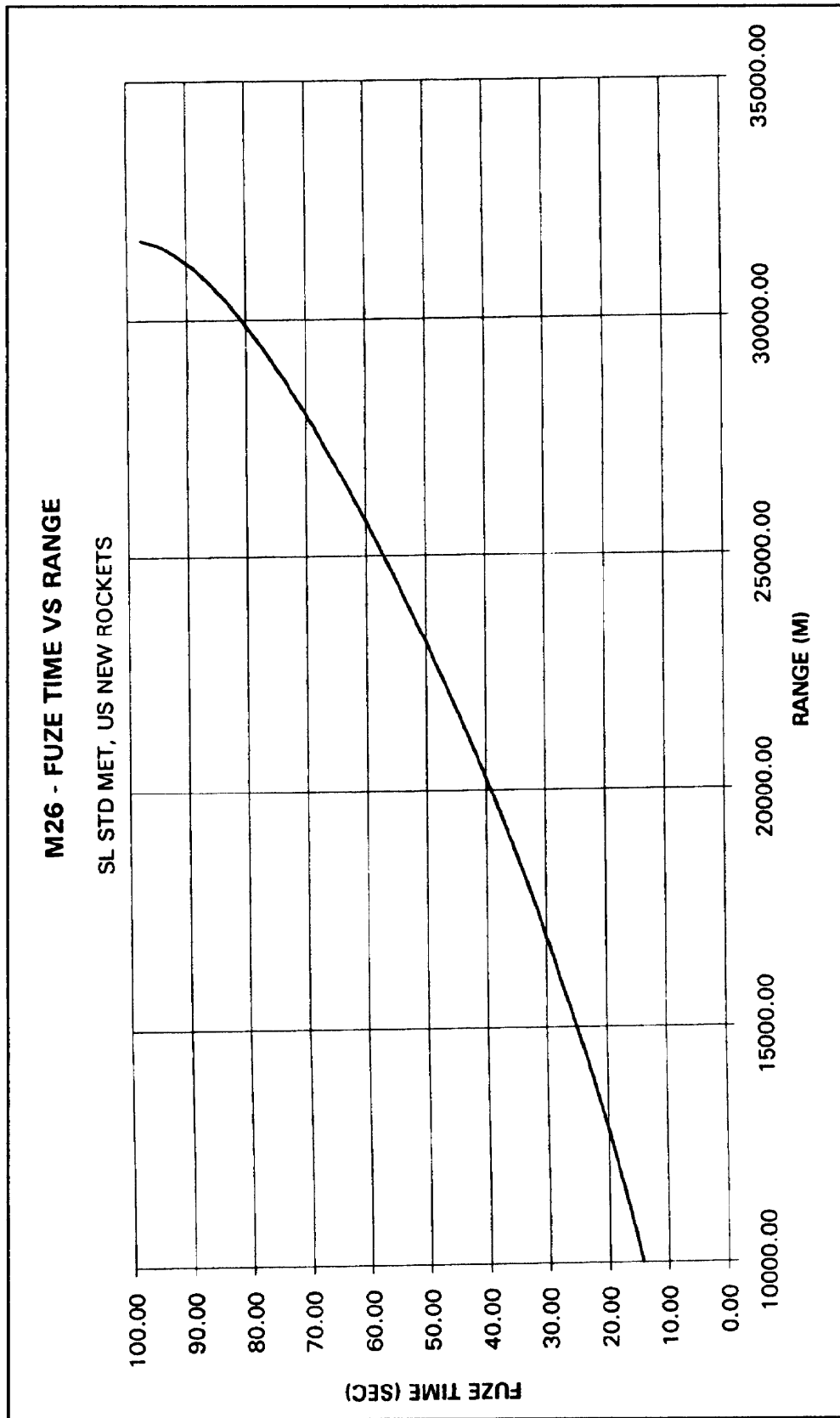

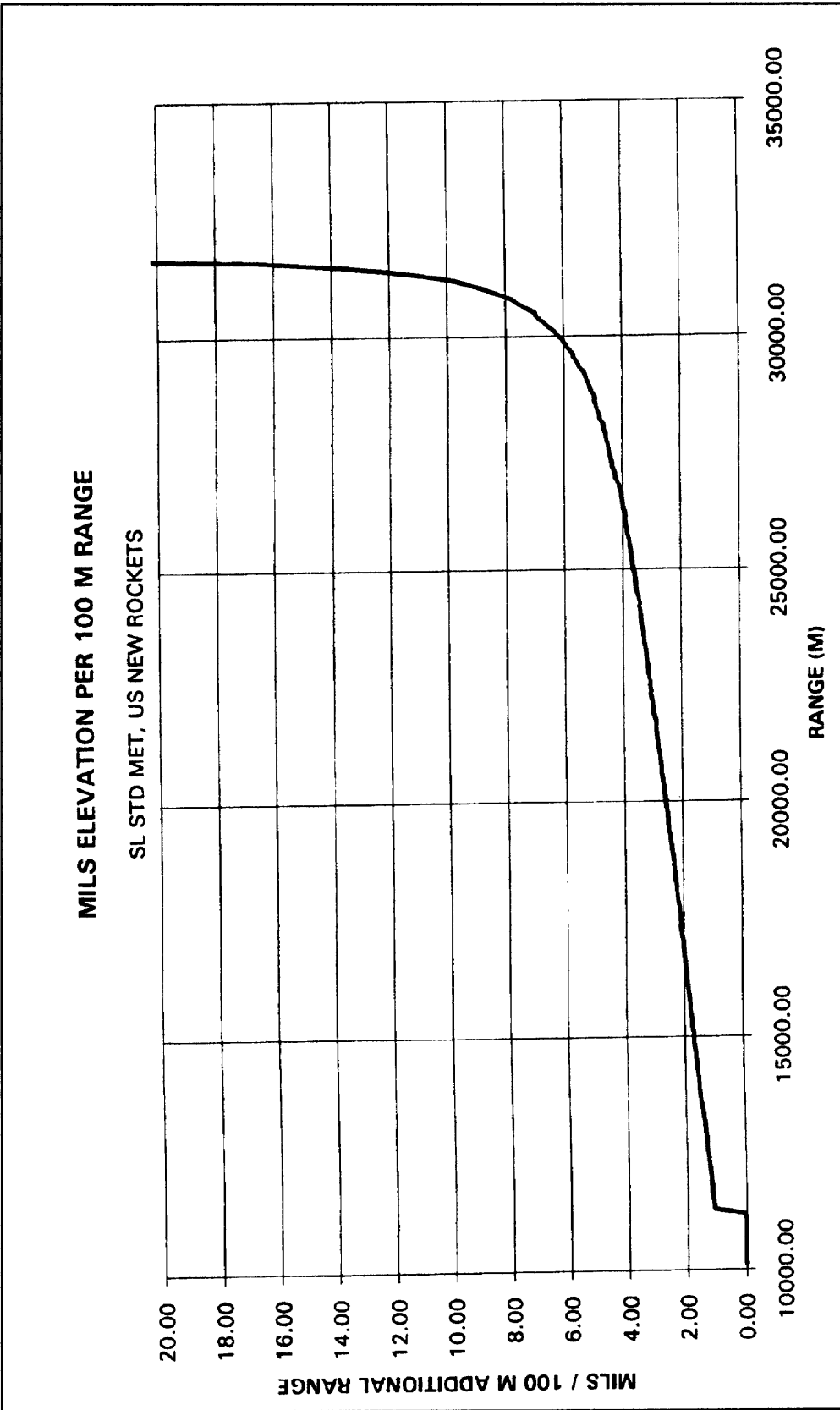

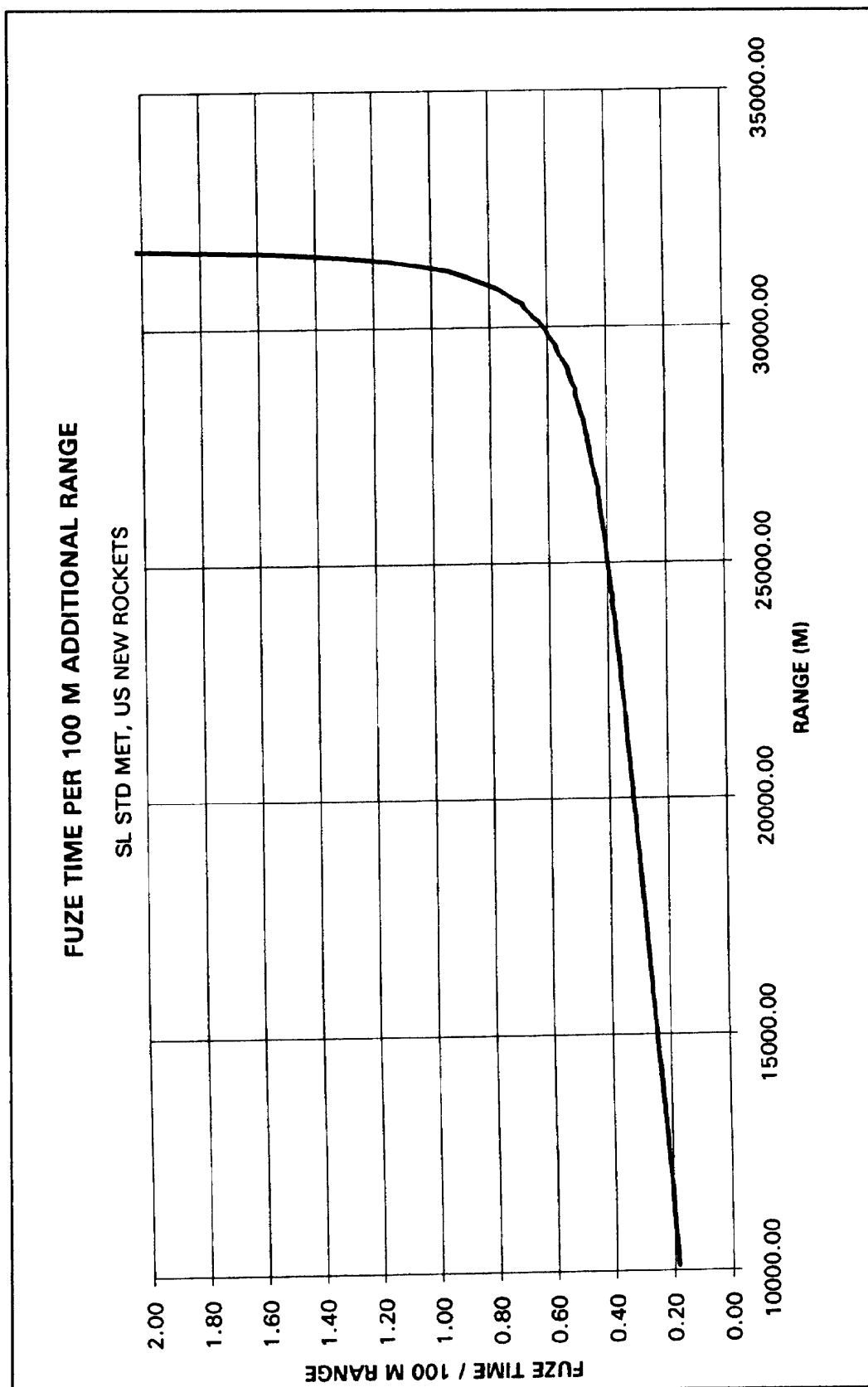

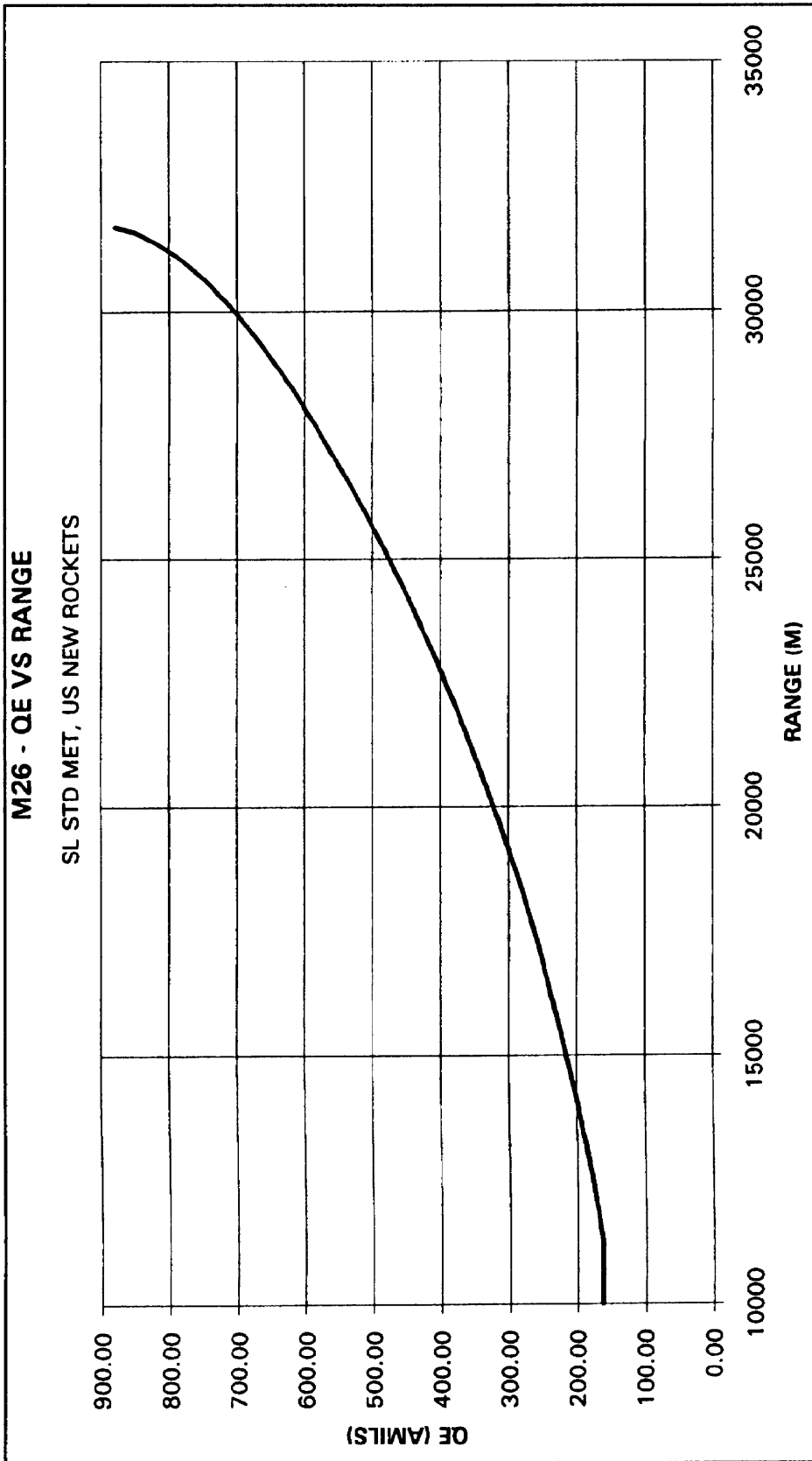

## M28A1 Rocket (Reduced Range, Practice) Ballistic Algorithm Solutions

AIM			APOGEE		
Range to Target (m)	QE (mils)	Time to Impact (sec)	Time (sec)	Altitude (m)	Range (m)
7,600	144.7	17.61	8.44	357	4,519
7,700	148.3	17.98	8.63	374	4,597
7,800	152.0	18.35	8.76	391	4,648
7,900	155.8	18.72	8.94	408	4,724
8,000	159.7	19.11	9.01	427	4,748
8,100	163.7	19.49	9.26	446	4,848
8,200	167.7	19.88	9.51	465	4,947
8,300	171.8	20.27	9.51	485	4,945
8,400	176.0	20.67	9.76	506	5,042
8,500	180.3	21.07	10.01	528	5,137
8,600	184.6	21.48	10.01	550	5,135
8,700	189.0	21.89	10.26	573	5,229
8,800	193.6	22.30	10.51	596	5,321
8,900	198.2	22.72	10.76	621	5,412
9,000	202.9	23.15	10.76	646	5,409
9,100	207.7	23.58	11.01	672	5,498
9,200	212.6	24.01	11.26	699	5,586
9,300	217.6	24.45	11.26	727	5,583
9,400	222.6	24.90	11.51	756	5,669
9,500	227.8	25.35	11.76	785	5,754
9,600	233.1	25.80	12.01	815	5,838
9,700	238.4	26.26	12.01	847	5,833
9,800	243.9	26.73	12.26	879	5,916
9,900	249.4	27.20	12.51	912	5,997
10,000	255.1	27.68	12.76	947	6,076
10,100	260.9	28.16	13.01	982	6,154

**FM 6-60**

**M28A1 Rocket (Reduced Range, Practice) Ballistic Algorithm Solutions (Continued)**

AIM			APOGEE		
Range to Target (m)	QE (mils)	Time to Impact (sec)	Time (sec)	Altitude (m)	Range (m)
10,200	266.8	28.65	13.01	1,019	6,149
10,300	272.8	29.14	13.26	1,056	6,226
10,400	279.0	29.64	13.51	1,095	6,301
10,500	285.2	30.15	13.76	1,135	6,375
10,600	291.5	30.66	14.01	1,176	6,449
10,700	298.0	31.18	14.26	1,218	6,521
10,800	304.6	31.71	14.51	1,262	6,591
10,900	311.4	32.24	14.76	1,307	6,661
11,000	318.2	32.79	14.76	1,353	6,652
11,100	325.2	33.33	15.01	1,401	6,720
11,200	322.4	33.89	15.26	1,450	6,786
11,300	339.7	34.46	15.51	1,500	6,851
11,400	347.1	35.03	15.76	1,553	6,915
11,500	354.7	35.61	16.01	1,606	6,978
11,600	362.4	36.20	16.26	1,662	7,039
11,700	370.3	36.79	16.51	1,719	7,099
11,800	378.4	37.40	16.76	1,778	7,158
11,900	386.7	38.02	17.01	1,839	7,214
12,000	395.2	38.65	17.26	1,902	7,270
12,100	403.9	39.29	17.51	1,968	7,324
12,200	412.8	39.95	17.76	2,035	7,376
12,300	421.9	40.62	18.26	2,106	7,496
12,400	431.3	41.30	18.51	2,178	7,544
12,500	441.0	42.00	18.76	2,254	7,590
12,600	450.9	42.71	19.01	2,332	7,634
12,700	461.1	43.44	19.26	2,413	7,676
12,800	471.6	44.19	19.51	2,498	7,716



**M28A1 Rocket (Reduced Range, Practice) Ballistic Algorithm Solutions (Continued)**

AIM			APOGEE		
Range to Target (m)	QE (mils)	Time to Impact (sec)	Time (sec)	Altitude (m)	Range (m)
12,900	482.5	44.96	20.01	2,586	7,819
13,000	493.7	45.75	20.26	2,679	7,853
13,100	505.4	46.56	20.51	2,775	7,883
13,200	517.6	47.41	21.01	2,877	7,975
13,300	530.3	48.29	21.26	2,984	7,999
13,400	543.6	49.20	21.76	3,098	8,081
13,500	557.6	50.16	22.26	3,218	8,157
13,600	572.5	51.17	22.51	3,347	8,164
13,700	588.4	52.24	23.01	3,487	8,226
13,800	605.6	53.39	23.51	3,640	8,277
13,900	624.5	54.64	24.01	3,809	8,316
14,000	645.8	56.04	24.76	4,001	8,397
14,100	670.6	57.66	25.26	4,228	8,393
14,200	702.3	59.69	26.26	4,521	8,455
14,300	760.1	63.32	27.76	5,063	8,448

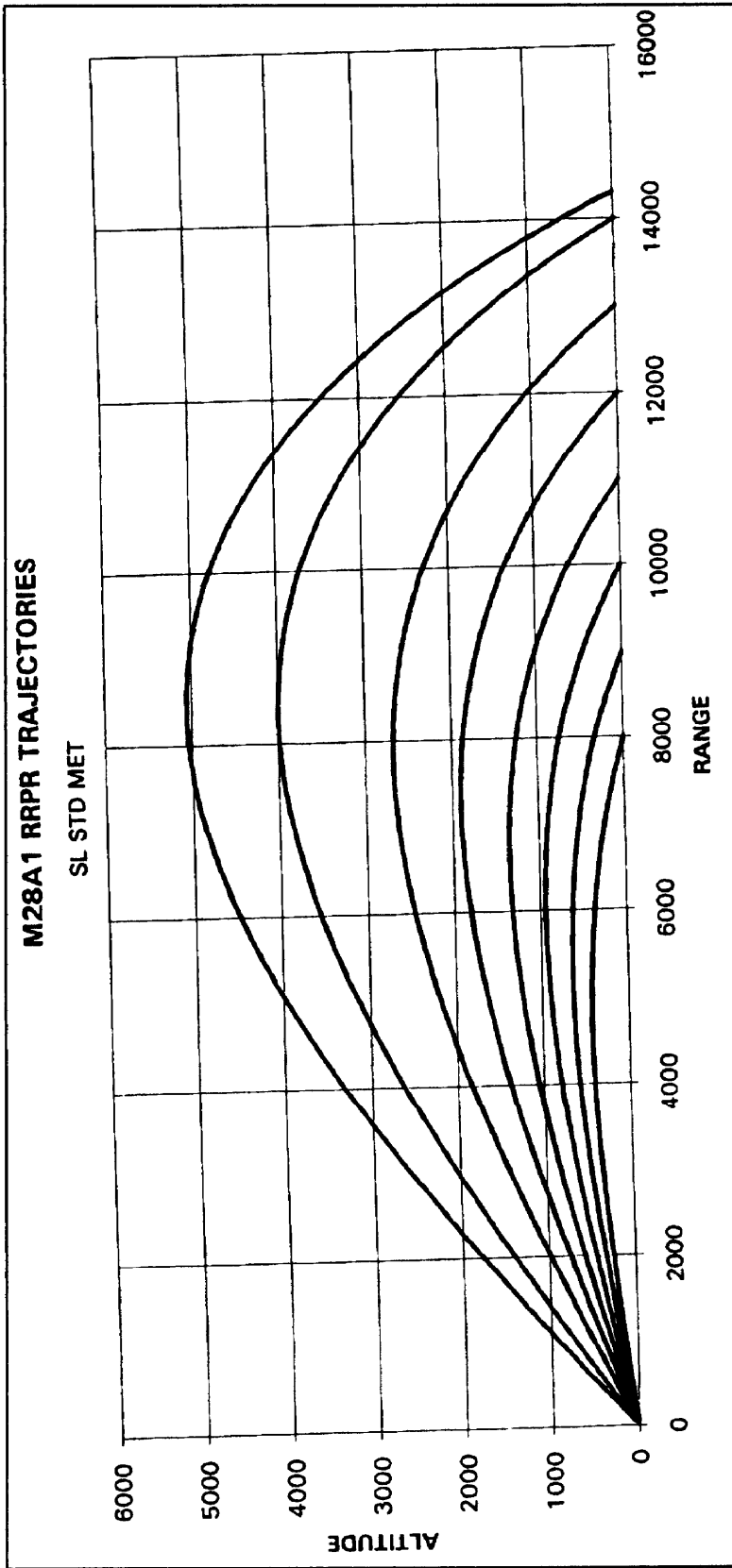

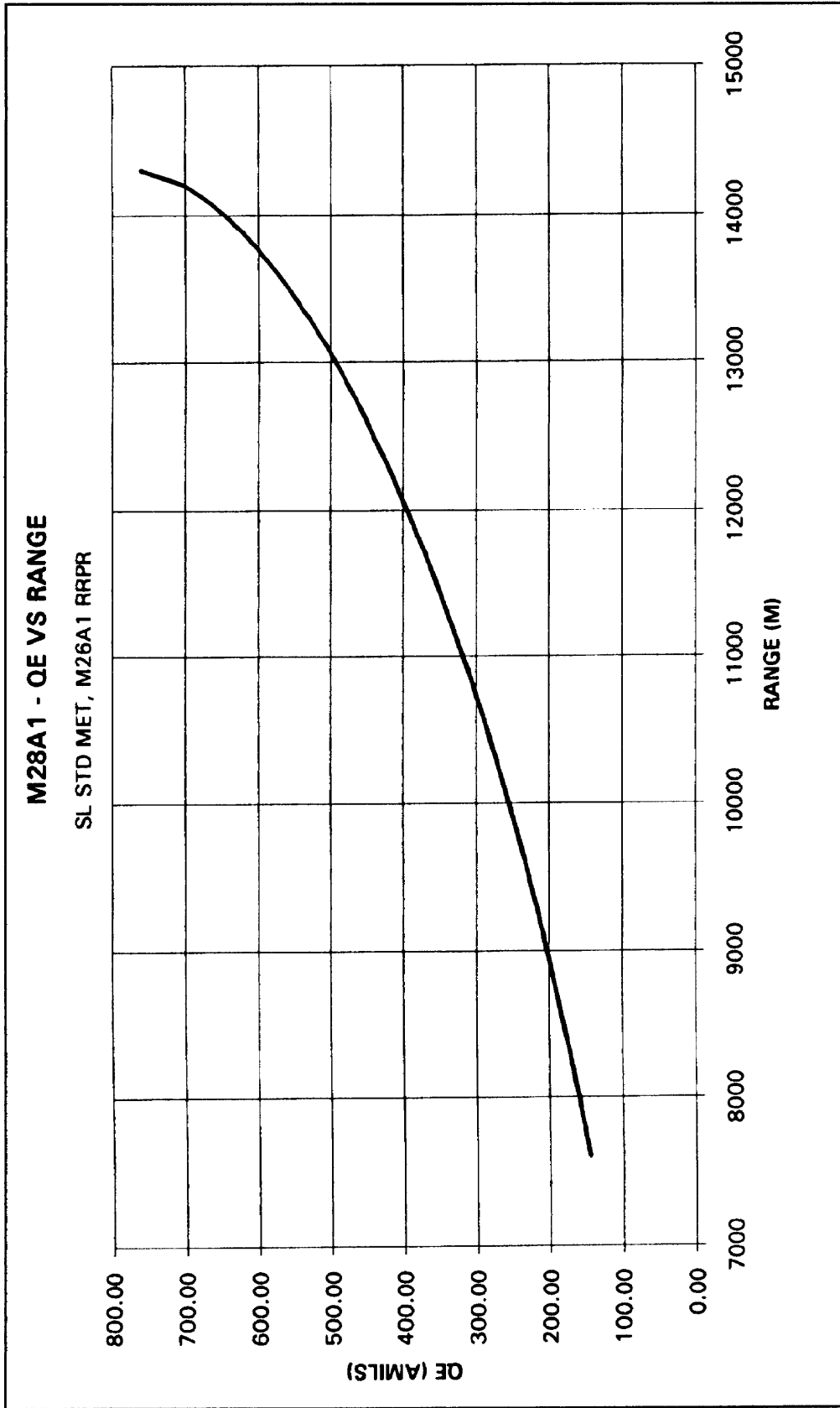

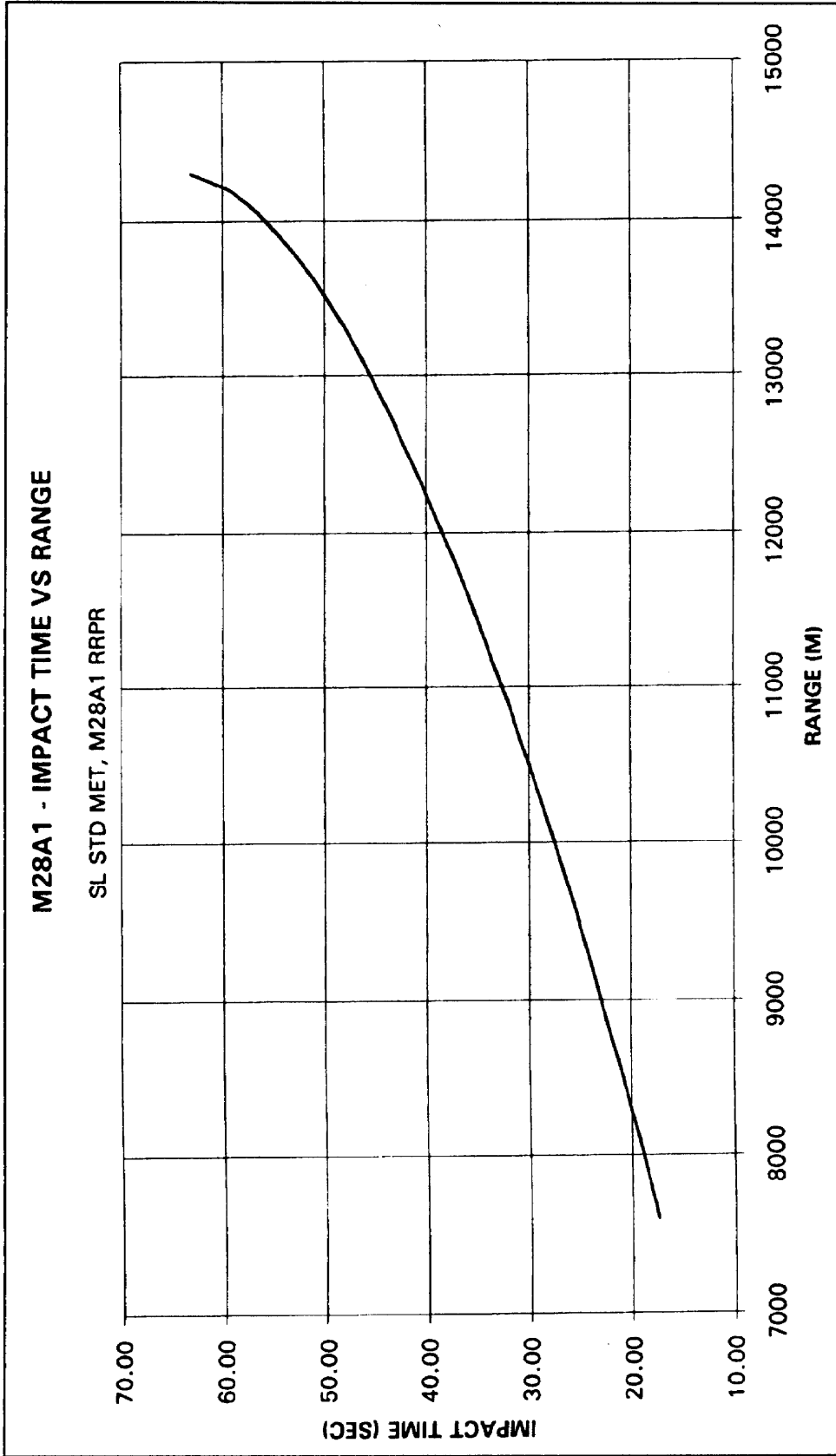

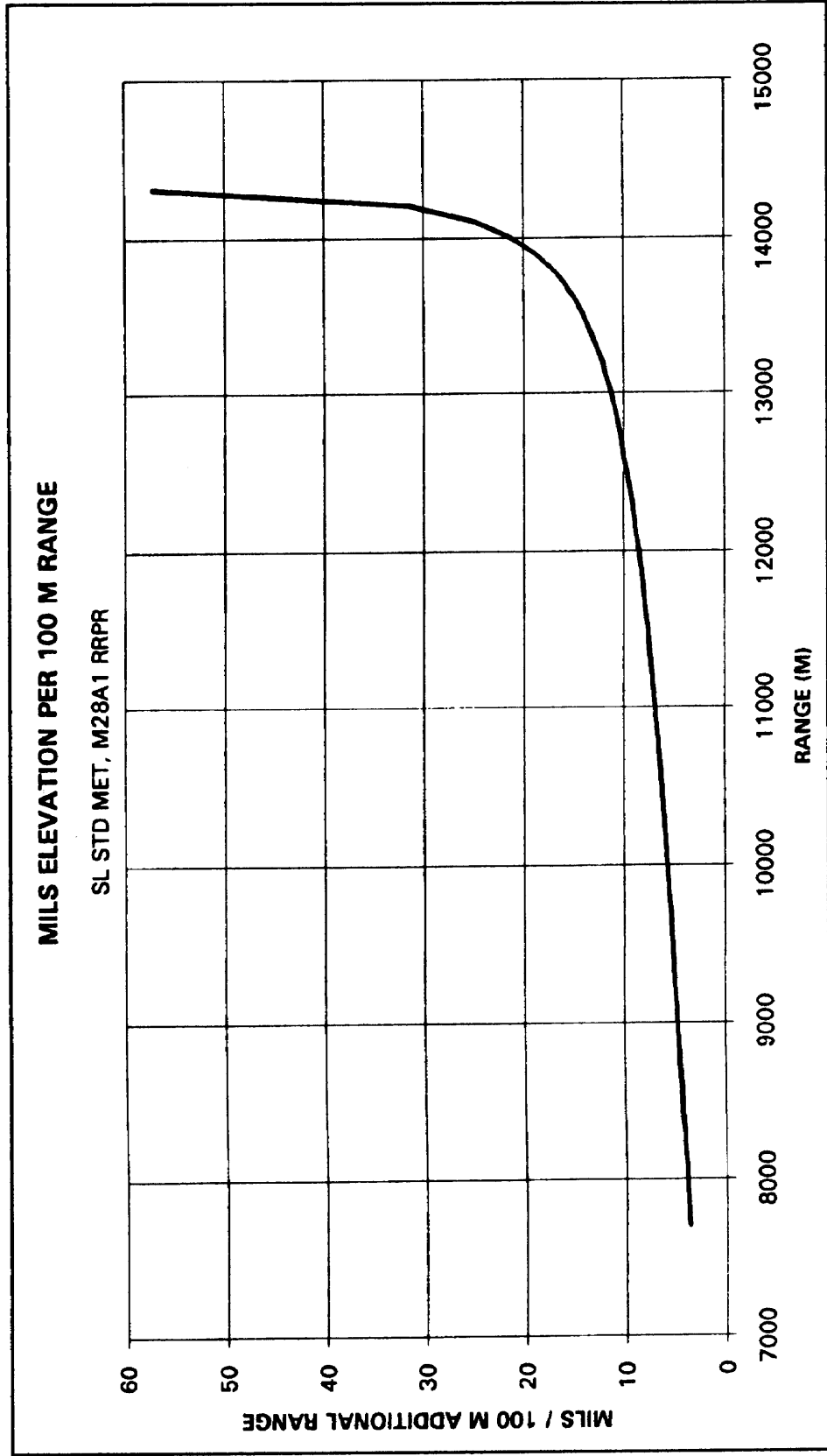

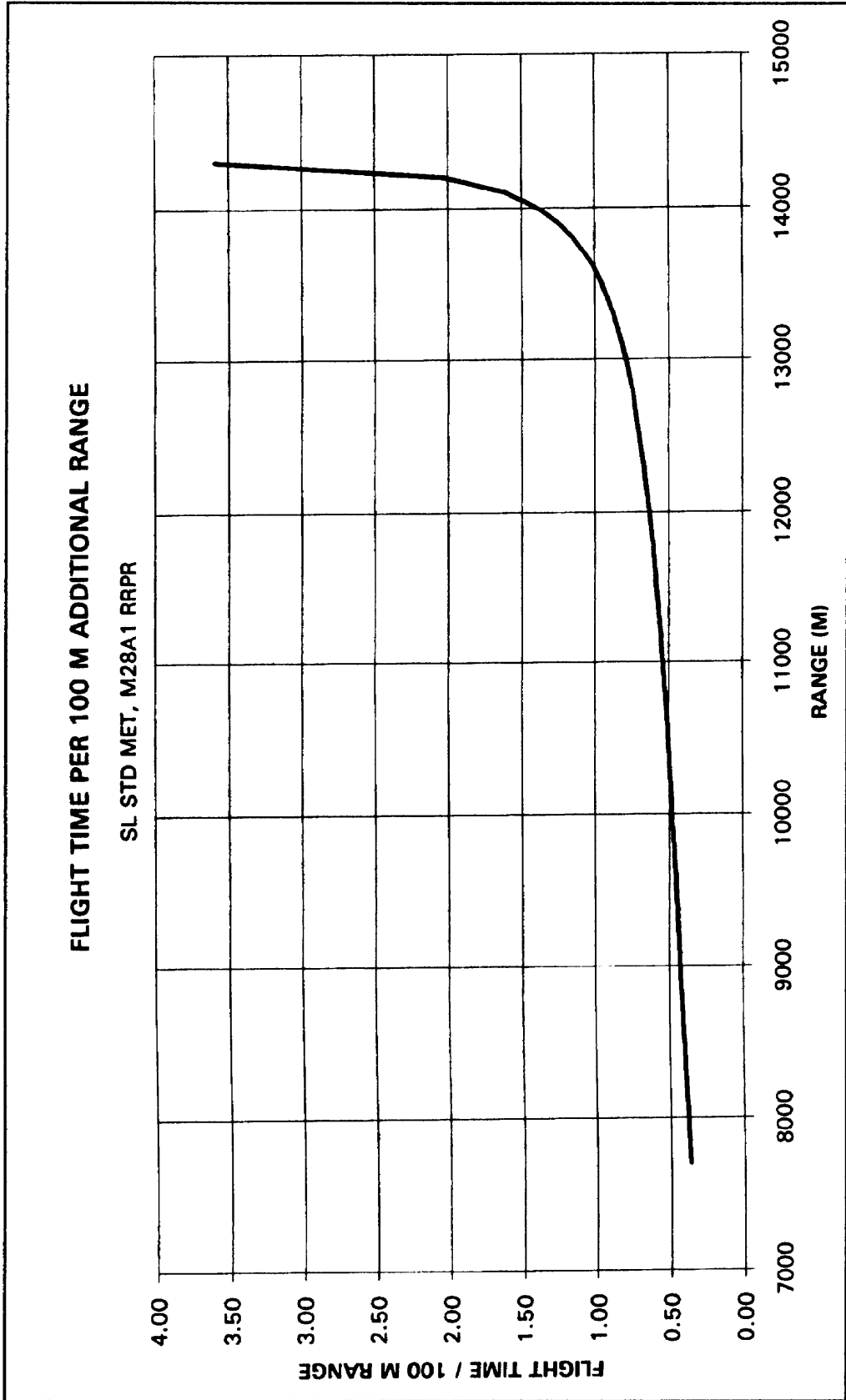

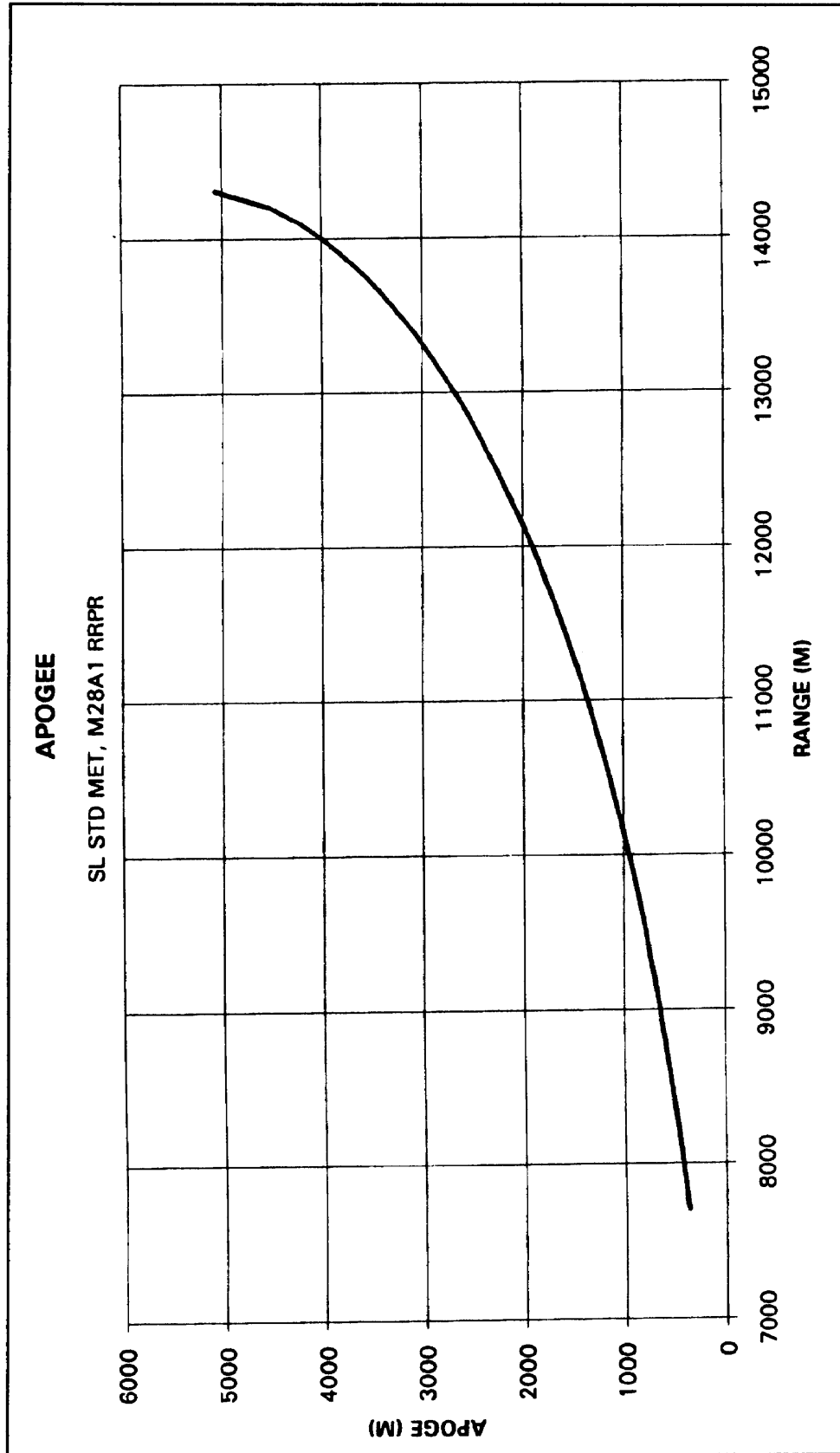

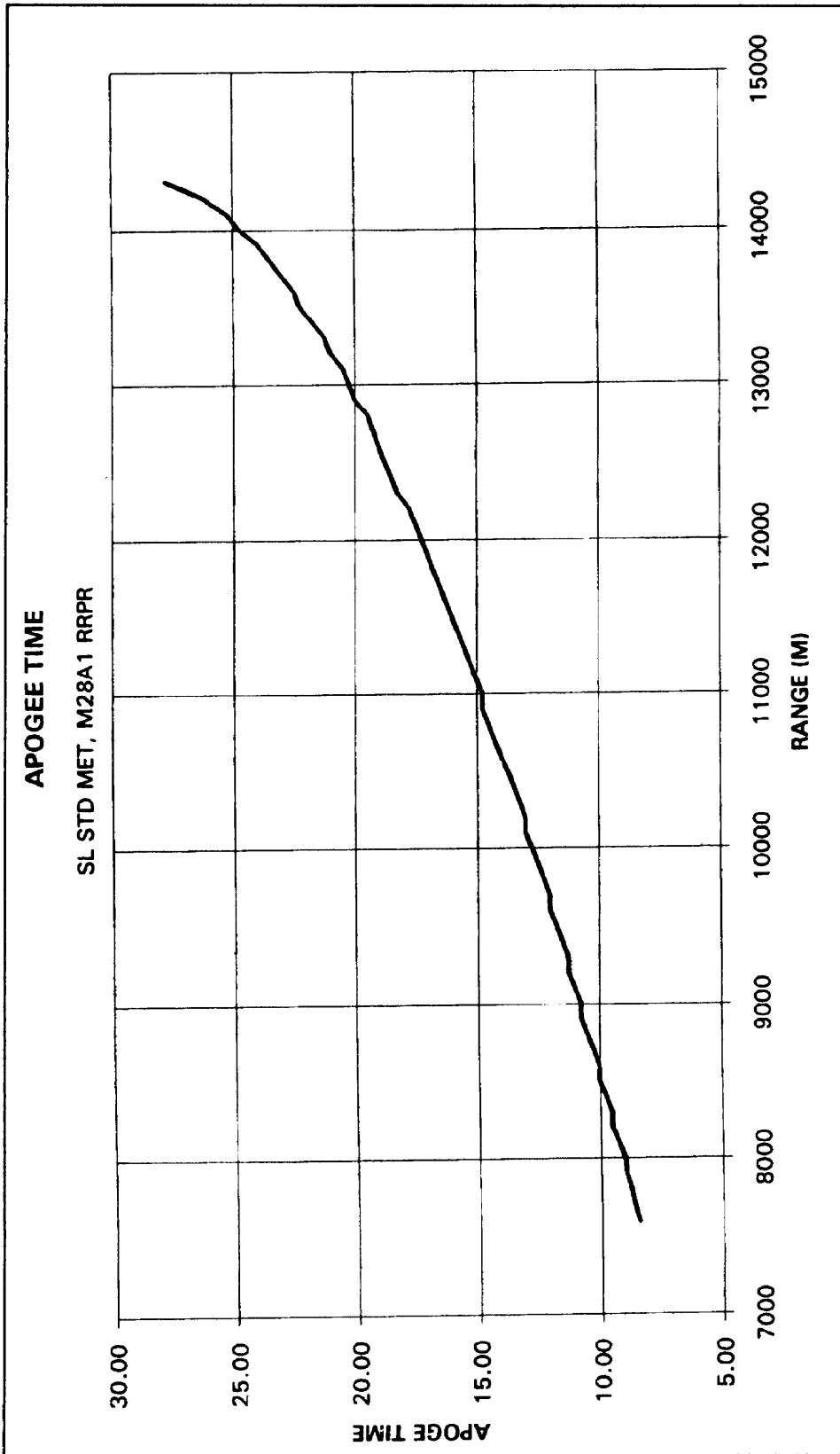



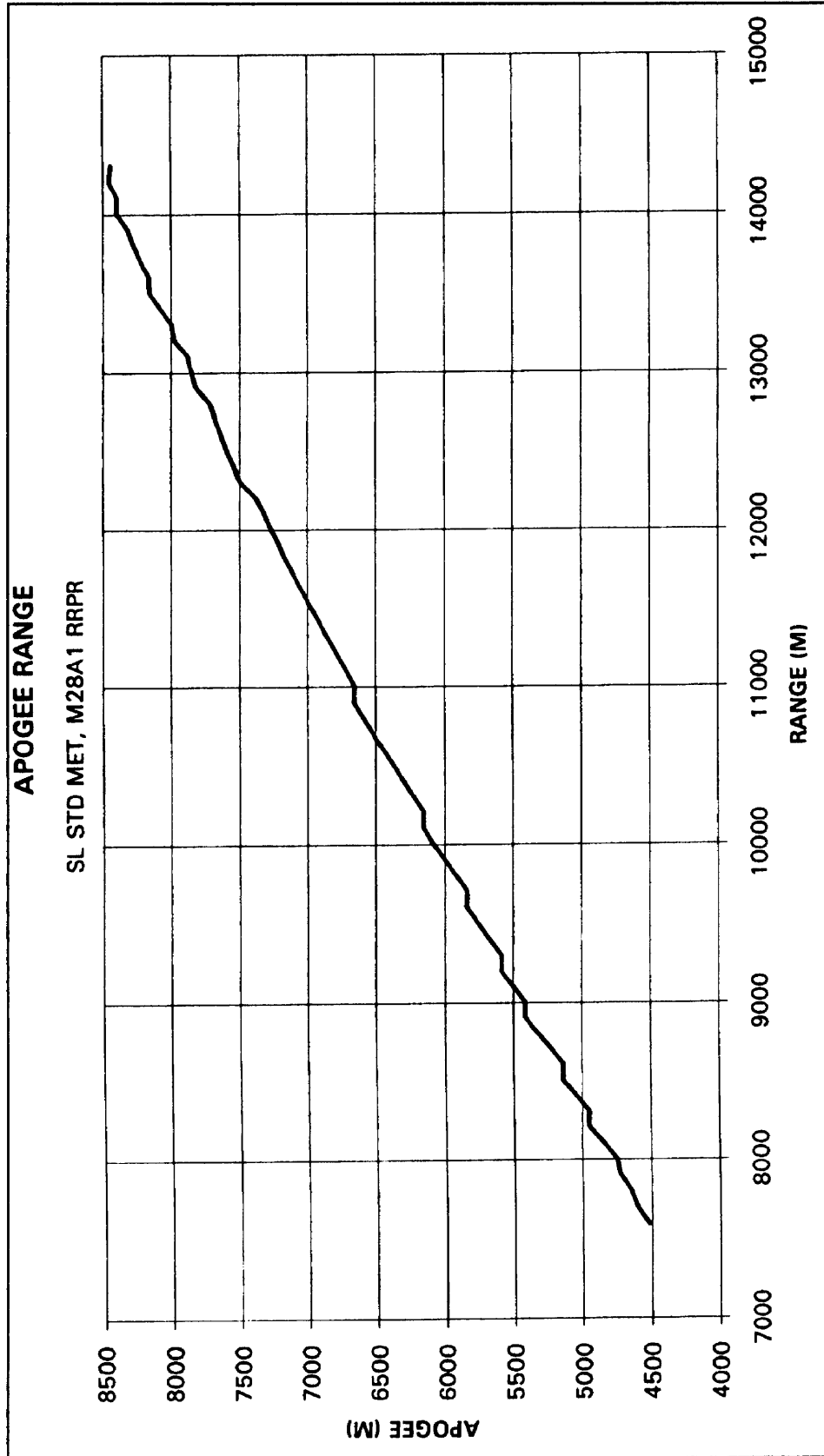

## GLOSSARY

## A

**A2C2** Army airspace command and control

**AAFES** Army and Air Force Exchange Service

**AAR** after action review

**acct** account

**ACE** analysis control element

**ACP** air control point

**ACR** armored cavalry regiment

**ADA** air defense artillery

**admin** administrative

**ADOCS** automated deep operations coordination system

**AFATDS** advanced field artillery tactical data system

**AFU** ammunition and fire unit

**AG** adjutant general

**AHA** ammunition holding area

**AIRCOR** air corridor

**ALOC** administrative and logistical operations center

**alt** altitude

**AMC** at my command

**ammo** ammunition

**AO** area of operations

**APA** Army prepositioned afloat

**APAM** antipersonnel and antimateriel

**app** appendix

**ArmyTACMS** Army tactical missile system

**ARTEP** Army training and evaluation program

**ARTY UNK** artillery, type unknown (mnemonic)

**ASAS/ACE** all-source analysis system/analysis control element

**ASL** authorized stockage list

**ASP** ammunition supply point

**atch** attached

**ATHS** airborne target handover system

**ATLASS** asset tracking for logistics and supply system

**ATP** ammunition transfer point

**ATIZ** artillery target intelligence zone

**avn** aviation

**az** azimuth

## B

**BAT** brilliant anti-armor technology submunition

**BC** battery commander, boom controller

**BDAR** battlefield damage assessment and repair

**bde** brigade

**BER** bit error rate

**BFVS** Bradley fighting vehicle system

**BIT** built-in test

**BITE** built-in test equipment

**BMO** battalion maintenance officer

**BMT** battalion maintenance technician

**bn** battalion

**BOC** battery operations officer

**BSO** battalion signal officer

**btry** battery

## C

**C2** command and control

**C3** command, control, and communications

**C3I** command, control, communications, and intelligence

**cat** category

**CBPS** chemically and biologically protected shelter system

**CDPU** communications data processing unit

**C-E** communications-electronics

**CEP** circular error probable

**CFF** call for fire

**CFFZ** call-for-fire zone

**CFZ** critical friendly zone

**CINC** commander-in-chief

## FM 6-60

**CMP** communications processor  
**CMSC** communications mode selector control  
**COC** command operations center  
**comm** communications  
**COMMZ** communications zone  
**COMSEC** commo security  
**coord** coordinate  
**COP** command observation post  
**COSCOM** corps support command  
**CP** command post  
**CS** combat support  
**CSA** corps storage area  
**CSB** common sensor boundary  
**CSEU** control system electronics unit  
**CSM** command sergeant major  
**CSR** controlled supply rate  
**CSS** combat service support  
**CSSD** combat service support detachment  
**CSSE** combat service support element  
**CTA** common table of allowances  
**CTT** commander's tactical terminal  
**CVC** combat vehicle crewman  
**CZ** censor zone

### D

**D3** decide-detect-deliver  
**D3A** decide-detect-deliver assess  
**DA** Department of the Army  
**DAO** division ammunition officer  
**DISCOM** division support command  
**div arty** division artillery  
**DMD** digital message device  
**DMMC** division materiel management center  
**DNE** do not engage  
**DNVT** digital nonsecure voice telephone

**DOCC** deep operations coordination cell  
**DOD** department of defense  
**DODIC** DOD identification code  
**DOP** degree of protection  
**DOS** days of supply  
**DPICM** dual-purpose improved conventional munitions  
**DR** downrange  
**DRA** data rate adaptor  
**DS** direct support  
**DSA** division support area  
**DSU** direct support unit  
**DSVT** digital secure voice terminal  
**DTG** date-time group

### E

**EA** engagement area  
**EAC** echelon above corps  
**EAD** echelon-above-division  
**ECCM** electronic counter-countermeasures  
**ECOF** effects cutoff factor  
**ED** emergency destruction  
**EEI** essential elements of information  
**ELMC** electronics maintenance company  
**EOD** explosive ordnance disposal  
**EPE** estimated position error  
**EPW** enemy prisoner of war  
**ER** extended range  
**EU** electronics unit  
**EW** electronic warfare

### F

**FA** field artillery  
**fax** facsimile  
**FCP** fire control panel; functional command post  
**FCS** fire control system  
**FCSB** forward corps support battalions

## Glossary-2

**FCU** fire control unit  
**FD** fire direction (radio net)  
**FDC** fire direction center  
**FDDM** fire direction data manager  
**FDO** fire direction officer  
**FDS** fire direction system  
**FEBA** forward edge of the battle area  
**FED** forward entry device  
**1SG** first sergeant  
**FH** frequency hopping  
**FIST** fire support team  
**FLOT** forward line of own troops  
**FM** frequency modulated  
**FM;CFE** call for fire  
**FM;FDSMOD** fire mission; fire direction system modification (mnemonic)  
**FM;FOCMD** forward observed command  
**FOM** figure of merit  
**FP** firing point  
**FRAGO** fragmentary order  
**FS** fire support  
**FSB** forward support battalion  
**FSC** field service company  
**FSCL** fire support coordination line  
**FSCM** fire support coordinating measures (mnemonic)  
**FSCoord** fire support coordinator  
**FSE** fire support element  
**FSEM** fire support execution matrix  
**FSSG** force service support group  
**ft** feet  
**FWR** fire when ready

**G**

**GCE** ground combat element  
**GCS** guidance and control section

**GMLA** guided missile launch assembly  
**GMT** Greenwich mean time  
**GPS** global positioning system  
**GS** general support  
**GSM** ground station module  
**GSR** general support reinforcing  
**GTA** graphic training aid

**H**

**HA** hide area  
**HEMAT** heavy expanded-mobility ammunition trailer  
**HEMTT** heavy-expanded-mobility tactical truck  
**HET** heavy equipment transport  
**HHB** headquarters and headquarters battery  
**HHS** headquarters, headquarters and service  
**HMMWV** high-mobility, multipurpose wheeled vehicle  
**HOB** height of burst  
**HPT** high payoff target  
**HQ** headquarters  
**HSS** health service support  
**HUMINT** human intelligence  
**HVT** high value target

**I**

**IAW** in accordance with  
**ICE** individual chemical equipment  
**ID(M)** infantry division (mechanized)  
**IFSAS** initial fire support automation system  
**IGAMMO** ignore ammunition (mnemonic)  
**IMINT** imagery intelligence  
**in** inch  
**INOP** inoperational  
**INTSUM** intelligence summary  
**IPB** intelligence preparation of the battlefield

## FM 6-60

### J

**JMEM/SS** joint munitions effectiveness manual for surface to surface

**JSTARS** joint surveillance target attack radar system

**JTF** joint task force

### K

**kg** kilogram

**km** kilometer

### L

**LCAC** landing craft, air cushion

**LCM-8** landing craft, mechanized

**LCU** lightweight computer unit

**LDF** lightweight digital facsimile

**LDS** launcher drive system

**LLM** launcher-loader module

**LNO** liaison officer

**LOC** logistics operations center; lines of communication

**LOS** line of sight

**LP** listening post

**LPC** launch pod container

**LRP** logistics release points

**LRU** line replaceable units

**LTACFIRE** light weight tactical fire direction system

### M

**m** meter

**MACOM** major Army command

**MAGTF** Marine air ground task force

**man** maneuver (attack guidance matrix)

**MAXRKTS** maximum rockets (mnemonic)

**mb** megabytes

**MBA** main battle area

**MCC** movement control center

**MCFSS** Marine Corps fire support system

**MDS** met data system

**MEB** Marine expeditionary brigade

**MEF** Marine expeditionary force

**METT-T** mission, enemy, terrain, troops, and time available

**MFOM** MLRS family of munitions

**MICOM** U. S. Army Missile Command

**MLRS** multiple launch rocket system

**MLRSIZ** multiple launch rocket system size (mnemonic)

**MMC** materiel management center

**MMS** met measuring set

**mod** modification

**MORT UNK** mortar, type unknown (mnemonic)

**MOU** memorandum of understanding

**MP** military police

**MPF** Maritime prepositional force

**MPT** mobile pay team

**MRL** multiple rocket launcher

**MSB** main support battalion

**MSE** mobile subscriber equipment

**msn** mission

**MSR** main supply route

**MSRTmobile** subscriber radiotelephone terminal

**MST** maintenance support team

**MSTAR** MLRS smart tactical rocket

**MTP** mission training plans

**MTOE** modification tables of organization and equipment

### N

**NAI** named area of interest

**NATO** North Atlantic Treaty Organization

**NBC** nuclear, biological, chemical

**NCO** noncommissioned officer

**NCS** net control station

**NHA** noise hazard area

**NLT** not later than

## Glossary-4

**NMC** not-mission-capable  
**NNFP** non-nuclear fire plans  
**NRI** net radio interface

**O**

**OIC** officer in charge  
**ONC** on call  
**OOTW** operations other than war  
**OP** observation post  
**OPAREA** operational area  
**OPCON** operational control  
**OPER** operational  
**OPLAN** operation plans  
**OPORD** operation order  
**OPSEC** operations security  
**OPTEMPO** operation tempo

**P**

**PA** physician assistant; position area  
**PAC** personnel and administration center  
**PADS** position and azimuth determining system  
**PBO** property book officer  
**PCU** power conditioner unit  
**PE** probable error  
**PIM** payload interface module  
**PIR** priority intelligence requirements  
**PL** phase line  
**PLGR** precision lightweight GPS receiver  
**PLL** prescribed load list  
**PLU** program load unit  
**PMCS** preventive maintenance checks and services  
**POC** platoon operations center  
**POL** petroleum, oils and lubricants

**Q**

**QE** quadrant elevation  
**QSTAG** quadripartite standardization agreement

**R**

**R** reinforcing  
**RAM** random access memory  
**RAU** remote access unit  
**RDF** radio direction finding  
**RDP** range-deflection protractor  
**REC** radio-electronic combat  
**recon** reconnaissance  
**retrans** retransmission  
**RF** radio frequency  
**rkt** rocket  
**RL** reload point  
**ROM** refuel on the move  
**ROZ** restricted operations zone  
**RP** release point  
**RSOP** reconnaissance, selection, and occupation of position  
**RSR** required supply rate  
**RSTA** reconnaissance, surveillance and target acquisition  
**RX** repairable exchange

**S**

**S1** adjutant  
**S2** intelligence officer  
**S3** operations officer  
**S4** battalion logistics officer  
**S&S** supply and service  
**SAIK** stand-alone installation kits  
**SCP** survey control point  
**SDA** surface danger area  
**SDZ** surface danger zone  
**SEAD** suppression of enemy air defenses  
**SEN** small extension nodes  
**SIGINT** signals intelligence

## FM 6-60

**SIGSEC** signals security  
**SIMO** simultaneous observation  
**SINCGARS** single-channel ground and airborne radio system  
**SITREP** situation report  
**SNVT** short/no-voltage tester  
**SOF** special operations forces  
**SOI** signal operation instruction  
**SOP** standing operating procedure  
**SP** start point  
**SPAP** special applications  
**SPAPS** special applications packages  
**SPBS** standard property book system  
**spt** support  
**SRP/PDS** stabilization reference package/position determining system  
**STANAG** standardization agreement  
**survl** surveillance  
**SVF** standard volleys factor  
**SYS;PTM** plaintext message (mnemonic)

### T

**TA** target acquisition  
**TAA** tactical assembly area  
**TACON** tactical control  
**TACFIRE** tactical fire direction system  
**TBP** to be published  
**TCF** tactical combat force  
**TCIM** tactical communications interface module  
**TD** tank division (Threat)  
**TDA** target damage assessment  
**TFC** tactical fire control  
**TID** TACFIRE interface device  
**TLE** target location error  
**TM** technical manual

**TMD** theater missile defense  
**TOC** tactical operations center  
**TOE** tables of organization and equipment  
**TOT** time on target  
**TSOP** tactical standing operating procedure  
**TTF** time to fire  
**TTP** tactics, techniques and procedures  
**TTT** timed time on target  
**TVA** target value analysis  
**TWR** timed when ready

### U

**UAV** unmanned aerial vehicles  
**UBL** unit basic load  
**ULLS** unit level logistics system  
**UMCP** unit maintenance collection point  
**US** United States  
**USAF** United States Air Force  
**USAFAS** United States Army Field Artillery School

### V

**(V)** voice (radio net)  
**VHF** very high frequency  
**vol** volleys  
**VSF** volleys size factor

### W

**WILCO** will comply  
**WLR** weapons locating radar  
**WMD** wind measuring device  
**WR** when ready  
**WSRO** weapon system replacement operations

### X

**XO** executive officer

## Glossary-6

## REFERENCES

## SOURCES USED

These are the sources quoted or paraphrased in this publication.

- AR 220-1.** *Unit Status Reporting*. 31 July 1993.
- AR 385-62.** *Regulations for Firing Guided Missiles and Heavy Rockets for Training, Target Practice and Combat*. 5 January 1977.
- AR 385-63.** *Policies and Procedures for Firing Ammunition for Training, Target Practice and Combat*. 15 October 1983.
- AR 385-64.** *Ammunition and Explosives Safety Standards*. 22 May 1987.
- FM 6-2.** *Tactics, Techniques & Procedures For Field Artillery Survey*. 23 September 1993.
- FM 6-15.** *Tactics, Techniques, and Procedures for Field Artillery Meteorology*. 18 June 1992.
- FM 6-20.** *Fire Support in the AirLand Battle*. 17 May 1988.
- FM 6-20-2.** *Tactics, Techniques and Procedures for Corps Artillery, Division Artillery, and Field Artillery Brigade HQ*. 7 Jan 93.
- FM 6-20-30.** *Tactics, Techniques, and Procedures for Fire Support for Corps and Division Operations*. 18 October 1989.
- FM 6-20-40.** *Tactics, Techniques, and Procedures for Fire Support for Brigade Operations (Heavy)*. 5 January 1990.
- FM 6-20-50.** *Tactics, Techniques, and Procedures for Fire Support for Brigade Operations (Light)*. 5 January 1990.
- FM 6-121.** *Tactics, Techniques, and Procedures for Field Artillery Target Acquisition*, 25 September 1990.
- FM 9-6.** *Munitions Support in Theater of Operations*, 1 September 1989.
- FM 24-1.** *Signal Support in the AirLand Battle*. 15 October 1990.
- FM 43-11.** *Direct Support Maintenance Operations (Non-Divisional)*. 5 September 1991.
- FM 54-30.** *Corps Support Groups*, 17 June 1993.
- FM 63-3J.** *Combat Service Support Operations, Corps*. 12 August 1985.
- FM 63-4.** *Combat Service Support Operations, Theater Army Area Command*. 24 September 1984.
- FM 63-20.** *Forward Support Battalion*. 26 February 1990.
- FM 63-21.** *Main Support Battalion*. 7 August 1990.
- FM 101-5-1.** *Operational Terms and Symbols*. 21 October 1985.
- FMFM 2-7.** *Fire Support in MAGTF Operational*.
- FMFM 4.** *Combat Service Support*.
- FMFM 6.** *Ground Combat Operations*.
- FMFM 6-9.** *Marine Artillery Support*. 29 Jun 93.
- FMFRP 6-17.** *Combat Service Support for Artillery Units*. 16 Jan 90.
- QSTAG 217.** *Tactical Tasks and Responsibilities for Control of Artillery*. Edition 2. 21 October 1991.
- STANAG 2934.** *Artillery Procedures*. Edition 1. 20 Jan 1989.
- TC 6-40A.** *Field Artillery Automated Cannon Gunnery*. 21 April 1989.
- TM 5-6675-308-12.** *Operator's and Organizational Maintenance manual for Position and Azimuth Determining System, AN/USQ-70*. 28 October 1988.
- TM 9-1300-206.** *Ammunition and Explosive Standards*. 30 August 1973.
- TM 9-1425-646-10.** *Manual for Launcher, Rocket, Armored Vehicle Mounted: M270...Multiple Launch Rocket System*. 20 June 1984.
- TM 9-1425-646-10-1 and -2.** *Operator's Manual for Launcher, Rocket, Armored Vehicle Mounted: M270.. (Multiple Launch Rocket System)*. 5 April 1990.
- TM 9-1425-646-20.** *Maintenance Instructions Organizational for Launcher, Rocket, Armored Vehicle Mtd, M270*. 6 April 1990.
- TM 9-1425-646-L** *List of Applicable Publications (LOAP) for Multiple Launch Rocket System*. 1 October 1992.



## FM 6-60

**TM9-1450-646-10.** *Operator's Manual for Carrier, Multiple Launch Rocket System, M993.* 3 August 1984.

**TM 9-2320-279-10-1.** *Operator's Manual Volume No 1 for M977 Series 8 x 8 Heavy Expanded-Mobility Tactical Trucks (HEMTT).* 21 November 1986.

**TM 9-2320-279-20-1.** *Maintenance Instructions for Organizational Maintenance M977 Series, 8 x 8 Heavy Expanded-Mobility Tactical Trucks (HEMTT).* 7 April 1987.

**TM 9-2320-279-20-2.** *Volume 2--Maintenance Instructions for Organizational Maintenance M977 Series, 8 x 8 Heavy Expanded-Mobility Tactical Trucks (HEMTT).* 7 April 1987.

**TM 9-2320-279-20-3.** *Maintenance instructions Organizational Maintenance M977 Series, 8 x 8 Heavy Expanded-Mobility Tactical Trucks (HEMTT).* 8 April 1987.

**TM 9-2330-368-14&P.** *Operator's Organizational, Direct Support, and General Support Maintenance Manual Including Repair Parts and Special Tools List for Trailer, Ammunition, Heavy Expanded-Mobility, 11-Ton, M989.* 5 December 1985.

**TM 9-6920-646-14.** *Operator's, Organizational, Direct Support and General Support Maintenance Manual for Rocket Pod, 298-mm, Training: M27... (Multiple Launch Rocket System).* 8 June 1984.

**TM 9-6920-647-14.** *Operator, Organizational, Direct Support and General Support Maintenance Manual for Trainer, Missile/Launch Pod Assembly... (Multiple Launch Rocket System).* 10 April 1990.

**TM 9-7440-648-12.** *Operator and Organizational Maintenance Manual for Communication System (Multiple Launch Rocket System).* 31 August 1990.

**TM 11-5820-890-10-1.** *Operator's Manual, Radio Sets AN/PRC-119...AN/VRC-87...AN/VRC-88...AN/VRC-89...AN/VRC-90...AN/VRC-91...AN/VRC-92.* 1 September 1992.

**TM 11-7440-283-12-1-2-1.** *Operator's Manual for Lance and Multiple Launch Rocket Systems, Fire Direction System AN/GYK-29(V).* 15 March 1990.

**TM 11-7440-283-12-1-2-2.** *Operator's Manual for Fire Direction System MLRS/Lance AN/GYK-29(V).* 15 March 1990.

**TOE 06398C000.** *Field Artillery Battery, Multiple Launch Rocket System, Heavy Division Artillery.*

**TOE 06465C000.** *Field Artillery Battalion (MLRS).*

**TOE 06466C000.** *Field Artillery Battalion, MLRS Headquarters, Headquarters and Service Battery.*

**TOE 06467C000.** *Field Artillery Firing Battery, Field Artillery Battalion (MLRS).*

## DOCUMENTS NEEDED

These documents must be available to the intended users of this publication.

**AR 700-138.** *Army Logistics Readiness and Sustainability.* 16 June 1993.

**ARTEP 6-398-30-MTP.** *Mission Training Plan for the Field Artillery Multiple Launch Rocket System Battery.* 8 July 1989.

**ARTEP 6-525-MTP.** *Mission Training Plan for the Field Artillery Multiple Launch Rocket System Battalion.* 11 January 1990.

**DA Form 581.** *Request for issue and Turn-in of Ammunition.* August 1989.

**DA Form 1156.** *Casualty Feeder Report.* June 1966.

**DA Form 1594.** *Daily Staff Journal or Duty Officer's Log.* November 1962.

**DA Form 2028.** *Recommended Changes to Publications and Blank Forms.* February 1974.

**DA Form 2404.** *Equipment inspection and Maintenance Worksheet.* April 1979.

**DA Form 2407.** *Maintenance Request.* August 1988.

**DA Form 2408.** *Equipment Log Assembly (Records).* January 1986.

**DA 2408-4.** *Weapon Record Data.* January 1979.

**DA 2408-14.** *Uncorrected Fault Record (Aircraft).* October 1991.

**DA Form 7232-R.** *MLRS FDC Fire Mission Log.* August 1992.

**DA Form 7233-R.** *MLRS Launcher Fire Mission Log.* August 1992.

**DA Pam 350-38.** *Standards in Weapons Training.* 15 February 1993.

**DA Pam 710-2-1.** *Using Unit Supply System (Manual Procedures).* 28 February 1994.

**DA Pam 738-750.** *Functional Users Manual for the Army Maintenance Management System (TAMMS).* 27 September 1991.

## References-2

- DDForm 2133.** *Joint Airlift Inspection Record.* November 1986.
- MAC Form 749.** *C-5A Passenger/Cargo Manifest.* November 1980.
- STP 6-13M14-SM-TG.** *Soldier's Manual and Trainer's Guide, Multiple Launch Rocket System Crew Member, MOS 13M, Skill Levels 1/2/3/4.* 8 December 1992.
- STP 6-13P-SM-TG.** *Soldier's Manual and Trainer's Guide, MLRS/Lance Operations/Fire Direction Specialist, MOS 13P, Skill Levels, 1/2/3/4.* 30 September 1991.
- TM 11-7440-283-12-1.** *Operator's and Organizational Maintenance Manual for Computer Groups, Gun Direction, OL-200/GYK-29(V) (P/O) Computer System, Gun Direction AN/GYK-29(V).* 24 September 1982.
- READINGS RECOMMENDED**
- These readings contain relevant supplemental information.
- AR 310-25.** *Dictionary of United States Army Terms.* 15 October 1983.
- AR 310-50.** *Authorized Abbreviations and Brevity Codes,* 15 November 1985.
- AR 350-41.** *Training In Units.* March 1993
- AR 380-5.** *Department of the Army Information Security Program.* 25 February 1988.
- DA Pam 700-19.** *Procedures of U.S. Army Munitions Reporting System.* 16 April 1993.
- FM 3-100.** *NBC Defense, Chemical Warfare, Smoke, and Flame Operations.* 23 May 1991.
- FM 5-250.** *Explosives and Demolitions.* 13 June 1992.
- FM 6-20-10.** *Tactics, Techniques, and Procedures for the Targeting Process.* 29 March 1990.
- FM 6-50.** *Tactics, Techniques, and Procedures for the Field Artillery Cannon Battery.* 20 November 1990.
- FM 9-6.** *Munitions Support in Theater of Operations.* 1 September 1989.
- FM 9-38.** *Conventional Ammunition Unit Operations,* 16 June 1993.
- FM 11-50.** *Combat Communications Within the Division (Heavy and Light).* 4 April 1991.
- FM 19-25.** *Military Police Traffic Operations.* 30 September 1977.
- FM 19-30.** *Physical Security.* 1 March 1979.
- FM 20-22.** *Vehicle Recovery Operations.* 18 September 1990.
- FM 21-26.** *Map Reading and Land Navigation.* 7 May 1993.
- FM 21-60.** *Visual Signals.* 30 September 1987.
- FM 23-9.** *M16A1 Rifle and M16A2 Rifle Marksmanship.* 3 July 1989.
- FM 23-67.** *Machinegun, 7.62-mm, M60.* 29 February 1984.
- FM 43-12.** *Division Maintenance Operations,* 10 November 1989.
- FM 55-30.** *Army Motor Transport Units and Operations.* 14 March 1980.
- FM 63-2.** *Division Support Command, Armored, Infantry and Mechanized Infantry Divisions.* 20 May 1991.
- FM 71-1.** *Tank and Mechanized Infantry Company Team.* 22 November 1988.
- FM 71-2.** *The Tank and Mechanized Infantry Battalion Task Force.* 27 September 1988.
- FM 71-3.** *Armored and Mechanized Infantry Brigade.* 11 May 1988.
- FM 71-100.** *Division Operations.* 16 June 1990.
- FM 100-2-1.** *Soviet Army Operations and Tactics.* 16 July 1984.
- FM 100-5.** *Operations.* 14 June 1993.
- FM 100-10.** *Combat Service Support.* 18 February 1988.
- FM 100-15.** *Corps Operation.* 13 September 1989.
- FM 101-10-1/2.** *Staff Officers Field Manual-- Organizational, Technical, and Logistical Data Planning Factors (Vol 2).* 7 October 1987.
- GTA 5-2-12.** *Coordinate Scale and Protractor.*
- (O) TB 9-380-101-21.** *Security Classification Guide for Multiple Launch Rocket System (U).* 19 January 1987.

## **FM 6-60**

**TB 55-46-1.** *Standard Characteristics (Dimensions, Weight, and Cube) for Transportability of Military Vehicles and other Outsize/Overweight Equipment.* 15 January 1993.

**TM 55-1425-646-14.** *Transportability Guidance for Launcher, Rocket, Armored-Vehicle Mounted XM270.* 16 August 1982.

**TM 55-2320-279-14.** *Transportability Guidance Heavy Expanded Mobility Tactical Truck (HEMTT).* 29 January 1987.

## INDEX

- adjutant (S1)
  - duties and responsibilities, 2-1, 2-3, 2-6, 4-3, 4-4, 6-21, 6-22
  - legal service support, 6-18
  - manning, 6-4
- administrative (admin)
  - radio nets, 7-5 through 7-8
  - see adjutant (S1)
  - see first sergeant
  - see logistics operations center (LOC)
- administrative and logistical operations center (ALOC)
  - general, 2-8, 4-2 through 4-4, 6-2 through 6-4
  - enemy prisoners of war (EPW), 6-23
  - maintenance time guideline, 6-11
  - radio nets, 7-6 through 7-8, 7-11
- advanced field artillery tactical data system (AFATDS), 1-13
- after action review (AAR)
  - Launcher Section Evaluation and Training, I-17
- air corridor (AIRCOR), 5-3
- airborne target handover system (ATHS), 3-7, 3-14
- all-source analysis system/analysis control element (ASAS/ACE), 5-1
- altitude (alt)
  - accuracy, 4-12 through 4-14
  - see survey
- ammunition (ammo)
  - administrative and logistical operations center (ALOC), 4-2, 4-3
  - ammunition expenditure, 6-7
  - ammunition platoon leader, 2-8
  - ammunition platoon sergeant, 2-9
  - basic load, 6-1, 6-6
  - battalion supply section, 2-3
  - battery ammunition platoon, 2-5
  - battery operations center, 4-5
  - identification chart, 6-7
  - munition selection matrix, 5-11
  - positioning planning, 5-9
  - resupply operations, 6-8, 6-9
  - see launch pod container
- ammunition holding area (AHA)
  - general, 6-6
  - operational area considerations, 4-18
  - positioning considerations, 4-6
- ammunition supply point (ASP)
  - general, 6-5
  - resupply operations, 6-8
- ammunition platoon leader, 2-8
- ammunition platoon sergeant, 2-9
- ammunition transfer point (ATP)
  - general, 6-5
  - resupply operations, 6-8
- analysis control element (ACE), 5-1
- antipersonnel and antimateriel (APAM), see M74 submunition
- Army prepositioned afloat (APA), 4-30
- Army TACMS
  - general, 1-7
  - delivery of fires, 5-1
- asset tracking for logistics and supply system (ATLASS), 6-25
- at my command (AMC)
  - general, 4-17, 5-3, 5-4
  - reaction time, 5-13
  - resource scheduling, 5-9
- authorized stockage list (ASL)
  - general, 6-14
  - Logistics operations with the Marine Corps, 6-25
- automated deep operations coordination system (ADOCS), 5-1
- battalion (bn)
  - fire direction center, 5-3
  - health service support, 6-18
  - logistics operations, 6-2, 6-3
  - maintenance support, 6-10, 6-11
  - mobile subscriber equipment (MSE), 7-11, 7-12

## FM 6-60

- battalion (bn) (cont.)
  - operations
    - headquarters, 4-1, 4-2
    - administrative and logistical operations center (ALOC), 4-3, 4-4
    - functional CP, 4-4
    - personnel duties, 2-6 through 2-8
    - radio net structure, 7-5, 7-6, 7-9
    - structure, 2-1
    - see chapter 4
- battalion commander, 2-6
- battalion logistics officer (S4)
  - general, 2-1, 2-3
  - administrative and logistical operations center (ALOC), 4-3, 4-4
  - ammunition, 4-3
  - duties and responsibilities, 2-6, 2-7, 4-30, 6-23
- battalion maintenance officer (BMO), 2-4, 2-7, 4-4, 6-10, 6-11
- battalion maintenance technician (BMT), 2-7, 4-4, 6-11
- battalion signal officer (BSO)
  - general, 2-1
  - duties and responsibilities 2-7, 4-4, 7-3
- battery (btry)
  - fire direction center, 5-3, 5-4
  - firing batteries, 2-4 through 2-6
  - headquarters and headquarters service btry, 2-1 through 2-4
  - health service support, 6-19
  - logistics operations, 6-3
  - maintenance operations, 6-11 through 6-14
  - operations, 4-4 through 4-15
  - personnel duties, 2-8 through 2-10
  - position selection and occupation, 4-22 through 4-24
  - radio net structure 7-7, 7-8, 7-10
- battery commander (BC)
  - general, 2-1, 2-5
  - duties and responsibilities, 2-7, 2-8
- battery operations center (BOC)
  - general, 2-5
  - fire mission cycle, 5-9, 5-10
  - operations, 4-5
- battery operations officer
  - general, 2-5
  - duties and responsibilities, 2-8
- battery motor sergeant, 2-10
- battlefield damage assessment and repair (BDAR), 6-9, 6-10
- bit error rate (BER), 7-12
- boom controller (BC), 1-3
- brilliant antiarmor technology submunition (BAT), 1-9, 6-7
- built-in test (BIT), 1-3
- built-in test equipment (BITE), 6-12
- call for fire (CFF), 3-6
- call-for-fire zone (CFFZ), 3-13, 3-14
- sensor zone (CZ), 3-14
- chemical officer, 2-7
- circular error probable (CEP)
  - ER rocket 1-12
  - survey 4-12, 4-13
  - see appendix C
- combat service support (CSS)
  - see chapter 6
- combat service support detachment (CSSD), 6-11
- combat service support element (CSSE), 6-25
- command and control (C2)
  - battalion 4-2
  - battery, 4-5,
  - platoon, 4-16
  - with Marine Corps, 3-8
- command, control, and communications (C3), 1-2, 1-10
- command post (CP)
  - battalion 2-7, 4-2
  - battery 3-5
  - functional command post, 4-4
  - composition, see appendix F

- command sergeant major (CSM)
  - general, 2-1
  - duties and responsibilities, 2-8, 4-4
- commander's criteria, 5-10 through 5-12
- communications security (COMSEC)
  - general, 1-3
  - battalion signal officer 7-3
  - SINCGARS, 7-12
  - with Marine Corps, 3-8
- communications (comm)
  - battalion operations, 4-1
  - battery operations, 4-5
  - communication electronics section, 2-3
  - launcher systems, 1-3
  - maintenance, 6-12
  - MLRS Communications, see chapter 7
  - with Marine Corps, 3-8
- communications data processing unit (CDPU), 1-11
- communications mode selector control (CMSC), 1-3
- communications maintenance, 6-12
- communications processor (CMP), 1-3, 1-4
- communications zone (COMMZ), 6-19, 6-21, 6-23
- control system electronics unit (CSEU), 1-8
- controlled supply rate (CSR), 6-6, 6-8
- corps storage area (CSA), 6-5
- corps support command (COSCOM), 6-1
- crest clearance tables, see appendix H
- critical friendly zone (CFZ), 3-13
- days of supply (DOS), 6-6
- decide-detect-deliver assess (D3A), 3-2
- deployment
  - general, 3-8, 4-26, 4-27
  - aerial transport, see appendix A
- digital nonsecure voice telephone (DNVT), 7-11
- direct support (DS)
  - maintenance, 6-10
  - tactical mission, 3-7
- division support area (DSA), 6-1
- division support command (DISCOM), 6-1
- DOD identification code (DODIC), 1-4, 6-7
- dual-purpose improved conventional munitions (DPICM), see M77 submunition
- echelon above corps (EAC), 5-1
- effects cutoff factor (ECOF), 5-11, 5-12
- electronic counter-countermeasures (ECCM), 7-3, 7-4
- electronics maintenance company (ELMC), 6-10
- electronics unit (EU), 1-3 through 1-5
- emergency destruction (ED), 4-7
- enemy prisoner of war (EPW), 6-23
- estimated position error (EPE), 1-12
- executive officer (XO)
  - general, 2-1
  - duties and responsibilities 2-6, 4-2, 4-3, 6-2, 6-11,
- extended range rocket (ER), 1-8, 1-9, 6-7
- facsimile (fax), 2-3, 7-11, 7-12
- field service company (FSC), 6-20
- figure of merit (FOM), 1-12, 4-13
- fire control panel (FCP), 1-3
- fire control system (FCS)
  - general, 1-3, 1-4, 1-5, 1-10
  - fire mission cycle 5-10
  - maintenance, 6-12
- fire control unit (FCU), 1-3
- fire direction (radio net) (FD), 5-3, 7-6 through 7-11

## FM 6-60

- fire direction center (FDC)
  - general, 2-2, 2-10
  - communications, 7-6, 7-7
  - deliver of fires, 5-2 through 5-8
  - planning process, 5-12
- fire direction computer, 2-10
- fire direction data manager (FDDM)
  - general, 1-2, 1-10, 1-11, 3-8, 5-2 through 5-4
  - planning and scheduling, 5-8
- fire direction officer (FDO)
  - general, 2-2
  - duties and responsibilities, 2-7
- fire direction system (FDS)
  - general, 1-2, 1-4, 1-10, 1-11, 3-8, 3-13, 4-14, 5-2 through 5-6
  - fire mission cycle, 5-9, 10
  - planning process, 5-12
  - maintenance, 6-12
  - communications, 7-5, 7-8
- fire support coordination line (FSCL), 3-3
- fire support element (FSE), 5-1, 5-12
- fire support execution matrix (FSEM), 5-6
- fire support plan, see appendix B
- fire support team (FIST), 3-6
- fire when ready (FWR), 5-3, 5-4, 5-12
- firing platoon leader, 2-9
- firing platoon sergeant, 2-9
- firing point (FP)
  - general, 2-10, 5-10
  - accuracies, 4-13
  - OPAREA, 4-16, 4-17
- firing section chief, 2-10
- first sergeant (1SG)
  - general, 2-1, 2-5
  - duties and responsibilities, 2-8, 2-9, 4-3, 4-9, 4-22, 6-4, 6-18
- force service support group (FSSG), 6-25
- formations, 4-9, 4-10, 4-29
- forward corps support battalions (FCSB), 6-1
- forward entry device (FED), 1-11, 2-5
- forward line of own troops (FLOT), 1-1, 3-2, 3-9 through 3-11, 3-13, 3-14, 4-17, 4-23
- forward support battalion (FSB), 6-1, 6-2
- frequency hopping (FH), 3-8, 7-12
- frequency modulated (FM)
  - communications, 1-4, 1-9, 3-2, 3-8, 7-4
  - nets, 3-6, 3-8, 7-3, 7-5 through 7-10
  - radios available, 1-3, 2-1, through 2-6, 4-3, 7-11
- functional command post (FCP), see command post
- general support (GS)
  - tactical mission, 3-5, 3-6, 7-7
  - maintenance, 6-10, 6-12, 6-25
- general support reinforcing (GSR), 3-5 through 3-7, 7-7
- global positioning system (GPS), 1-9, 1-12, 4-12
- ground station module (GSM), 3-15
- guidance and control section (GCS), 1-7, 1-8
- guided missile launch assembly (GMLA), 1-2, 1-5
- headquarters and headquarters battery (HHB), 2-1, 2-4
- headquarters, headquarters and service (HHS)
  - general, 2-1 through 2-4, 4-2, 6-2, 6-11
  - communications, 7-6
- health service support (HSS), 6-18
- heavy expanded-mobility ammunition trailer (HEMAT), 1-2, 1-9, 1-10, 2-5, 6-6, 6-8
- heavy-expanded-mobility tactical truck (HEMTT), 1-2, 1-9, 1-10, 2-3 through 2-5, 3-17, 6-6, 6-8
- hide area (HA), 2-10, 4-17, 4-18
- high-mobility, multipurpose wheeled vehicle (HMMWV), 2-2 through 2-5, 3-15, 4-3,

- human intelligence (HUMINT), 4-6
- ignore ammunition (IGAMMO), 5-10, 5-11
- imagery intelligence (IMINT), 4-6
- intelligence officer (S2)
  - general, 2-1
  - duties and responsibilities, 2-2, 2-6, 7-3
- intelligence preparation of the battlefield (IPB), 3-1
- initial fire support automation system (IFSAS), 1-4, 1-10, 5-1, 5-2, 5-11, 5-12
- joint munitions effectiveness manual for surface to surface (JMEM/SS), 5-7
- joint surveillance target attack radar system (JSTARS), 3-13, 3-15
- joint task force (JTF), 1-3, 3-1, 4-26, 5-1, 6-7
- landing craft, air cushion (LCAC), 4-30
- landing craft, mechanized (LCM-8), 4-30
- launch pod container (LPC), 1-2, 1-5, 1-6
- launcher drive system (LDS), 1-3
- launcher-loader module (LLM), see M269 LLM
- launcher posture, 4-19
- launcher section evaluation and training, see appendix I
- liaison officer (LNO)
  - general, 2-3, 2-7, 3-6, 4-3
  - checklist, see appendix E
- lightweight tactical fire direction system (LTACFIRE), 1-4, 1-10, 5-12
- lightweight computer unit (LCU), 1-10, 6-12
- lightweight digital facsimile (LDF), 7-12
- line replaceable units (LRU), 4-28, 6-10
- listening post (LP), 4-6, 4-25
- logistics operations center (LOC), 4-5, 6-8, 6-11
- logistics release points (LRP), 6-3
- M26 rocket, 1-6, 3-1, 3-2, 5-11, 6-7
- M269 launcher-loader module (LLM)
  - general, 1-2, 1-2 through 1-4,
  - maintenance, 6-10, 6-12
- M270 launcher
  - general, 1-2, 3-1, 5-5
  - survivability, 3-3
- M28 rocket, 1-6, 6-7
- M28A1 rocket, 1-7, 6-7
- M39 missile
  - general, 1-7, 1-8, 3-1, 5-11, 6-7
  - deep operations, 3-2
- M74 submunition (APAM), 1-8, 1-9, 3-1, 5-11, 6-7
- M77 submunition (DPICM), 1-6, 1-7, 1-9, 3-1, 3-2, 3-7, 4-28, 5-11, 6-7
- M993 carrier vehicle, 1-2
- main support battalion (MSB), 6-1, 6-10
- maintenance support team (MST), 6-9 through 6-12
- Marine air ground task force (MAGTF)
  - general, 1-1, 3-7, 3-8, 4-30
  - liaison, 2-3, 4-3
  - logistics, 6-26
  - maintenance, 6-11
- Marine Corps fire support system (MCFSS), 1-4, 1-10, 3-8
- Marine expeditionary brigade (MEB), 3-7, 3-8
- Marine expeditionary force (MEF), 3-8, 4-26, 6-26
- Maritime prepositional force (MPF), 4-31
- masking data, 4-24
- maximum rockets (MAXRKTS), 5-10, 5-11
- met data system (MDS), 1-10, 4-14
- met measuring set (MMS), 1-10, 4-14



## FM 6-60

- meteorological support, 4-14, 4-15
- missiles, see M39 missile, 1-2, 1-9, 3-3, 3-9, 5-5
- mission, enemy, terrain, troops, and time available (METT-T)
  - deployment, 3-8
  - staff organization, 4-2
  - RSOP, 4-21, 4-22
- MLRS family of munitions (MFOM), 1-6 through 1-8, 3-1, 3-3, 6-7
- MLRS smart tactical rocket (MSTAR), 1-9
- mobile subscriber equipment (MSE), 7-11, 7-12
- movement control center (MCC), 6-17
- multiple launch rocket system size (MLRSIZ), 5-12
- NBC NCO, 2-10
- net control station (NCS), 7-6, 7-8
- non-nuclear fire plans (NNFP)
  - reaction time, 3-3, 5-12, 5-13
- observation post (OP), 4-6, 4-25
- on call (ONC), 5-3
- operational area (OPAREA)
  - general, 4-16 through 4-18
  - platoon, 4-23, 4-24
- operational control (OPCON), 3-4, 3-5, 3-9
- operations
  - battalion, 4-1 through 4-4
  - battery, 4-4 through 4-15
  - communications, 7-4, 7-5
  - contingency operations, 4-25 through 4-30
  - defensive, 3-9, 3-10
  - fueling, 6-15
  - logistics, 6-2, 6-3
  - maintenance, 6-11 through 6-14
  - Marine Corps, 3-7, 3-8
    - logistics, 6-25
  - moving, 6-17
  - offensive, 3-9
  - other than war, 3-15 through 3-17
  - platoon, 4-16 through 4-21
  - operations (cont.)
    - resupply, 6-8, 6-9
    - special operations 4-28 through 4-30
    - war, 3-1 through 3-15
    - weapon system replacement, 6-24
  - operations officer (S3)
    - general, 2-1
    - communications, 7-3
    - duties and responsibilities, 2-2, 2-6
  - organization for combat, 3-4 through 3-7
  - payload interface module (PIM), 1-3
  - personnel and administration center (PAC), 2-3, 6-4
  - petroleum, oils and lubricants (POL), 6-15
  - physician assistant (PA), 2-7, 4-4
  - planning
    - general, 3-2
    - communications, 7-3 through 7-5
    - fire support, 5-8 through 5-9
    - RSOP, 4-22
  - platoon operations center (POC), 4-16
  - position and azimuth determining system (PADS), 1-11, 1-12, 4-12, 4-13
  - positioning
    - general, 3-2
    - ammunition, 5-9
    - headquarters, 4-5, 4-6, 4-22
    - platoon OPAREA, 4-23, 4-24
  - power conditioner unit (PCU), 1-11
  - precision lightweight GPS receiver (PLGR), 1-12, 2-3 through 2-6, 4-3, 4-13
  - prescribed load list (PLL), 2-4, 2-5, 6-12, 6-14, 6-26
  - preventive maintenance checks and services (PMCS), 4-9
  - probable error (PE), 4-12, 4-13
  - program load unit (PLU), 1-4
  - property book officer (PBO), 2-7, 2-8, 4-4

- quadripartite standardization agreement (QSTAG)
  - QSTAG 269, 1-9 through 1-12
  - QSTAG 217, 3-1 through 3-15
- radio direction finding (RDF), 3-4, 4-6, 7-2
- reconnaissance (recon), 4-22
- reconnaissance, selection, and occupation of position (RSOP), 4-21 through 4-25
- rehearsal, 3-11 through 3-13
- reinforcing (R), 3-6, 3-7
- release point (RP), 4-9, 4-10
- reload point (RL), 4-18, 6-6
- remote access unit (RAU), 7-11
- remote transmitters, 7-4
- repairable exchange (RX), 6-10, 6-14
- required supply rate (RSR), 6-6
- retransmission (retrans), 7-4
- rockets
  - general, 1-1, 1-5, 1-6, 1-8, 1-9, 6-7
  - ballistics, see appendix C
  - ballistic algorithms, see appendix K
  - control, 5-1
  - planning, 3-3
  - see M26 rocket, M28 rocket, M28A1 rocket
- safety, see appendix J
- senior food operations sergeant, 2-10
- short/no-voltage tester (SNVT), 1-3
- signal operation instruction (SOI), 7-3
- signals intelligence (SIGINT), 4-6
- single-channel ground and airborne radio system (SINCGARS), 1-3, 3-8, 7-12
- small extension nodes (SEN), 7-11
- special applications (SPAP), 1-11, 5-2
- stabilization reference package/position determining system (SRP/PDS), 1-2, 1-3
- standard volleys factor (SVF), 5-11
- standardization agreement (STANAG)
  - STANAG 2934, chapter 11, 1-9 through 1-12
  - STANAG 2934, chapter 3, 3-1 through 3-15
- start point (SP), 4-9
- supply and service (S&S), 6-19, 6-21, 6-23
- supply sergeant, 2-10
- survey
  - general, 4-12 through 4-14
  - equipment, 1-11, 1-12
  - hasty, see appendix G
  - launcher survey control, 4-12 through 4-14, 4-18
  - survey control point (SCP), 4-18
- tables of organization and equipment (TOE), 2-1, 2-4
- TACFIRE interface device (TID), 1-11
- tactical communications interface module (TCIM), 1-10
- tactical control (TACON), 2-2, 2-8, 2-9, 3-4, 3-6
- tactical fire control (TFC), 5-10
- tactical fire direction system (TACFIRE)
  - general, 1-4, 1-10, 3-8
  - communications, 7-5
- tactical operations center (TOC), 4-2, 4-3
- tactical standing operating procedure (TSOP)
  - see chapter 4
  - see appendix D
- target acquisition (TA), 3-8, 3-13 through 3-15
  - communications, 7-5
- target location error (TLE), 1-6, 1-8
- theater missile defense (TMD)
  - general, 1-1, 2-1, 2-3, 2-4, 3-1
  - communications, 7-5
- time on target (TOT), 5-3, 5-8, 5-9, 5-13

## **FM 6-60**

time to fire (TTF), 5-3, 5-4, 5-8, 5-9

timed time on target (TTT), 5-3

timed when ready (TWR), 5-3

unit basic load (UBL), 6-6

unit level logistics system (ULLS), 6-26

unit maintenance collection point (UMCP), 4-4, 6-9, 6-11,  
6-22

unmanned aerial vehicles (UAV), 3-8, 3-13 through 3-15

very high frequency (VHF), 7-4 through 7-8

voice (radio net)(V), 7-5 through 7-8

volleys (vol), 5-6, 5-11, 5-12

volleys size factor (VSF), 5-11

weapon system replacement operations (WSRO), 6-24

weapons locating radar (WLR), 3-8

when ready (WR), 5-3, 5-9

wind measuring device (WMD), 1-8



# MLRS FDC FIRE MISSION LOG (CONTINUED)

## INSTRUCTIONS

### IDENTIFICATION

Enter the date the form is initiated. Every 24-hour period (at 0001), change date with entire line entry across form on first unused line.

Enter the complete unit designation (for example, 2/A/4/27 FA).

### DATA

- (a) Enter the target number.
- (b) Enter target grid easting (four digits) (nearest 100 meters).
- (c) Enter target grid northing (four digits) (nearest 100 meters).
- (d) Enter the unit assigned the mission (platoon or launcher). For multiple launcher fire, use additional lines, leaving C, D, and E blank immediately below the first entry for that mission.
- (e) Enter the time mission is received.
- (f) Enter the number of rounds assigned for the target (if effects type, enter percent requested and/or number of rounds).
- (g) Enter the type of ammunition by J-code.
- (h) Enter the method of control or TOT time.
- (i) Enter the time mission is transmitted to the platoon launcher.
- (j) Enter mission status (for example, ADVRDY, CANCOM, EXECUT, AIMING, ARMED, FIRING, CCMCOM, TIMDEP, MFMTMN, READY, MISFIR, HNGFIR, or CKFIRE).
- (k) Enter time platoon or launcher fired the mission (time mission fired report [MFR] received).
- (l) Enter number of rounds fired on target.
- (m) Enter any additional information specific to this mission (for example, fire plan name, EOM (for end of mission), misfires, hangfires, reassigned, and so forth).



# MLRS LAUNCHER FIRE MISSION LOG (CONTINUED)

## INSTRUCTIONS

### IDENTIFICATION

Enter rank and last name of section chief.

Enter the complete unit designation, to include launcher number (for example, 1/2/A/4/27 FA).

Enter date form is initiated. Every 24-hour period, change date with single line entry across entire form.

### DATA

- (a) Enter target number.
- (b) Enter target grid coordinates (eight digits).
- (c) Enter actual fire point grid.
- (d) Enter the method of control.
- (e) Enter actual AZ fired.
- (f) Enter actual QE fired.
- (g) Enter FZ TIME setting (N/A for M28A1).
- (h) Enter the type of ammunition by Department of Defense identification code (DODIC) (H104, PL81).
- (i) Enter the number of rounds assigned for the target.
- (j) Enter the number of rounds fired. If different than (i), explain in Remarks column.
- (k) Enter time of first fire.

FM 6-60/MCRP 3-1.6.24  
23 APRIL 1996

By Order of the Secretary of the Army:

Official:

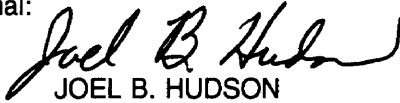

JOEL B. HUDSON

*Acting Administrative Assistant to the  
Secretary of the Army*

01521

DENNIS J. REIMER  
*General, United States Army  
Chief of Staff*

By Direction of the Commandant of the Marine Corps:

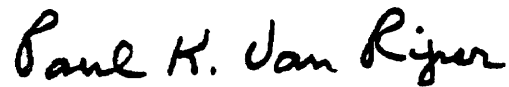

Paul K. Van Riper  
Lieutenant General, U.S. Marine Corps  
Commanding General  
Marine Corps Combat Development Command  
Quantico, Virginia

**DISTRIBUTION:**

**Active Army, USAR, and ARNG:** To be distributed in accordance with DA Form 12-11E, requirements for FM 6-60/MCRP 3-1.6.24, *Tactics, Techniques, and Procedures for Multiple Launch Rocket System (MLRS) Operations* (Qty rqr. block no. 4317).



**PIN: 021523-000**